

KD

Separazione polvere Dust separating system Entstaubungssysteme

Mod. KD01

Mod. KD04-S

Mod. KD04

Mod. KD07

Mod. KD12

Caratteristiche tecniche

- Realizzati per depolverare materiale plastico macinato, con filtrazione e rilascio dell'aria filtrata in ambiente lavorativo.
- Funzionamento automatico ed indipendente, collegabili a granulatori/trituratori nuovi e/o esistenti.
- Cinque modelli, disponibili per varie esigenze.
- Modello base KD01, compatto ed economico.
- Modello KD04-S, facilmente adattabile a molteplici esigenze, con filtro in depressione a cartucce autopulenti.
- Tre modelli, KD04, KD07, KD12, dotati di aspirazione in depressione dell'aria e filtrazione a cartucce autopulenti.
- Accessori: supporti Big-Bag, barre anti statiche, separatori di metallo.

Technical data

- Designed for de-dusting of plastic regrind. Filtered, dust-free air returned to ambient atmosphere.
- Can be floor standing or can be fitted to both new and existing granulators/shredders.
- Five models available for a variety of applications.
- Basic model KD01, low cost and space saving.
- Model KD04-S, easy to use and versatile. Features automatic cleaning cartridge filter working with negative air pressure.
- Three models, KD04, KD07, KD12, equipped with negative air suction system and air filtration system with automatic cartridge filter.
- Accessories: Big-Bag supports, anti-static bars, metal separators.



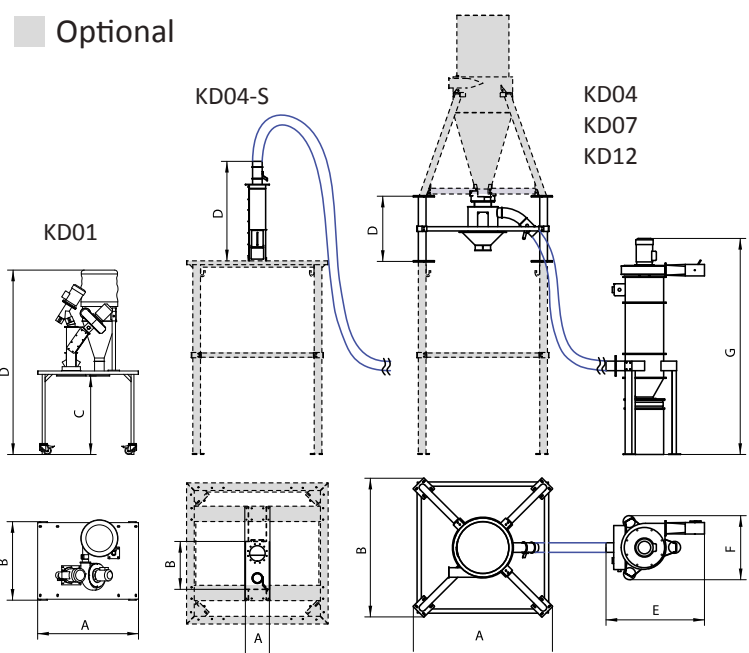

Technische daten

- Hergestellt zur Entstaubung von Mahlgut. Trennung der Luft in Umgebungs- / Arbeitsluft und filtrierte Luft für den Staubtransport.
- Automatische & unabhängige Funktion adaptierbar für Schneidmühlen/Shredder neu und/oder bestehend.
- Fünf Modelle sind verfügbar, geeignet für verschiedene Anwendungen.
- Basismodell KD01, günstig und benötigt wenig Aufstellfläche.
- Modell KD04-S einfach verwendbar für unterschiedliche Anwendungen, mit automatischer Filterabreinigung der Cartridge Filter. Arbeitsweise mit „negativem“ Luftfördersystem.
- Drei Modelle KD04, KD07, KD12, ausgestattet mit „negativem“ Luftfördersystem und Luftfiltrationssystem und automatischer Abreinigung der Cartridge Filter.
- Zubehör: Big-Bag Gestell, Antistatische Barrieren, Metallseparatore.



CARATTERISTICHE - TECHNICAL DATA - TECHNISCHE DATEN							
	A	B	C	D	E	F	G
KD01	1050	820	820	1925	-/-	-/-	-/-
KD04-S	250	500	-/-	1050	1025	670	2256
KD04	1448	1448	-/-	681	1025	670	2256
KD07	1448	1448	-/-	681	1230	915	2365
KD12	1448	1448	-/-	681	1230	915	2810

-/- Parti non incluse nel kit / Parts not included / Teile nicht enthalten

CARATTERISTICHE - TECHNICAL DATA - TECHNISCHE DATEN			
	 Kg/H	 KW	 dm ³
KD01	0/200	0,1	/
KD04-S	0/500	0,75	50
KD04	0/500	0,75	50
KD07	0/1000	1,1	50
KD12	0/1500	2,2	50