

# SHC, USC & EF Series

## Drying Hoppers

### Advantages:

- Solid cone hopper insures mass flow
- Laser-cut Hinged Clean-Out Door
- Heavy-duty lid and door clamps
- Fully insulated, cone to lid, including the access door
- Clear sight glass windows
- Material drain-out port
- Slide gate material shut-off
- Machine, mezzanine or stand mounted
- Three models available

The USC, SHC and EF series drying hoppers are designed to promote the mass flow of a wide variety of materials. The use of a solid cone in place of a perforated diffuser cone results in better air distribution, quick and efficient material drying, improved mass flow and a hopper that is easy to clean. For processing virgin pellets to thin flake and other difficult-to-flow material, there is a drying hopper to meet your most demanding needs.

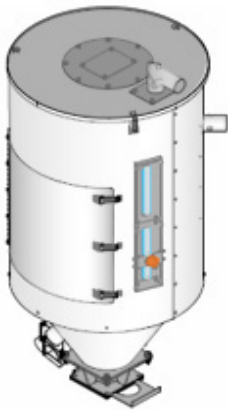

### SHC Hopper:

- 0.7 to 28.6 cubic feet capacity

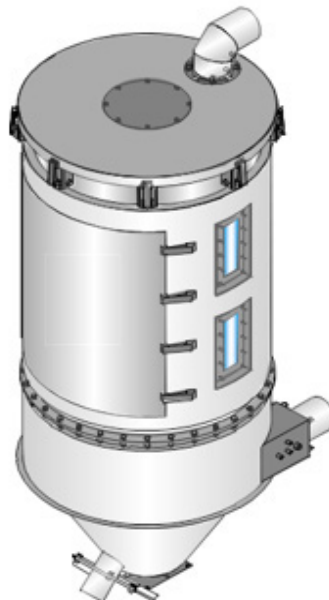

### USC Hopper:

- 32 to 575 cubic feet capacity

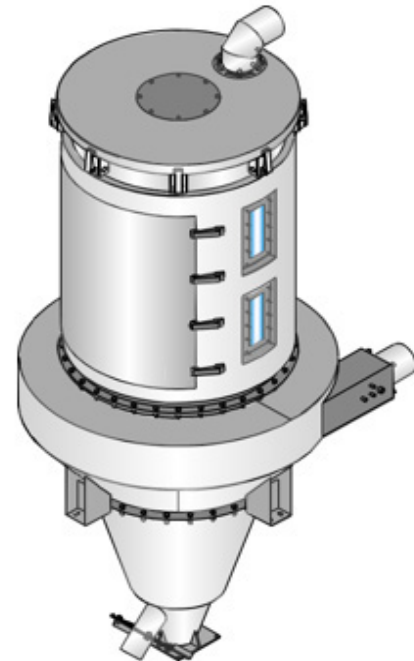

### Easy Flow Hopper:

- 32 to 343 cubic feet capacity
- Difficult-to-flow materials such as regrind and flake