



# Temperature Controllers

OPERATION,  
INSTALLATION AND  
MAINTENANCE  
MANUAL

Aquatherm RQT  
Standard

Where water  
means business.



Please record your equipment's model and serial number(s) and the date you received it in the spaces provided.

It's a good idea to record the model and serial number(s) of your equipment and the date you received it in the User Guide. Our service department uses this information, along with the manual number, to provide help for the specific equipment you installed.

Please keep this User Guide and all manuals, engineering prints, and parts lists together for documentation of your equipment.

Date:

---

Serial Number(s):

---

Model Number(s):

---

**DISCLAIMER:** Neither Thermal Care nor its employees shall be liable for errors contained in this User Guide or for incidental, consequential damages in connection with the furnishing, performance or use of this information. Thermal Care makes no warranty of any kind with regard to this information, including, but not limited to, the implied warranties of merchantability and fitness for a particular purpose.

# Table of Contents

## 1-1 Introduction

Purpose of the User Guide .....	1-2
How the Guide is Organized .....	1-2
Your Responsibility as a User .....	1-2
ATTENTION: Read This So No One Gets Hurt.....	1-3
Zero Energy State (ZES).....	1-4

## 2-1 Description

What is the Aquatherm RQT Standard .....	2-2
Typical Applications .....	2-2
How the RQT Standard Direct Injection Works .....	2-3
RQT Standard Control Features vs RQT Premium and RQT Advanced.....	2-4
Specifications: RQT Standard .....	2-5

## 3-1 Installation

Unpacking the Boxes .....	3-2
Preparing for Installation.....	3-3
Installation - Electrical .....	3-6
Connecting Process and Water Supply Lines <u>Without</u> Purge .....	3-7
Connecting Process and Water Supply Lines <u>With</u> Purge .....	3-8
Connecting the Main Power Source.....	3-9
Testing the Installation .....	3-10
Initial Setup.....	3-11
RQT Standard Control Setup .....	3-11
Changing Temperature Units .....	3-12
Additional RQT Standard Control Setup .....	3-12

## 4-1 Operation

The RQT Standard Control.....	4-2
Home Screen Display.....	4-3
User Parameters.....	4-3
Starting the RQT Standard temperature control unit .....	4-4
Stopping the RQT Standard temperature control unit .....	4-5
Using the Mold Purge Option .....	4-6
Selecting Tuning Parameters .....	4-7
RQT Standard Control Vent Timer Adjustment .....	4-8

## 5-1 Maintenance

Maintenance of Your RQT Standard temperature control unit.....	5-2
Preventive Maintenance Schedule.....	5-2
Accessing the RQT Standard temperature control unit Enclosure.....	5-3
Removing the Pump Motor and Seal .....	5-4
Reassembling the Pump Motor and Seal .....	5-7
Resetting Pump Overload.....	5-9
Replacing Pump Overload.....	5-9
Replacing the PLC.....	5-10
Replacing the Heater Contactor.....	5-11
Replacing the RTD .....	5-12
Repairing Cooling Valves.....	5-13
Disassembly of Optional Direct Acting Solenoid Valves .....	5-14
Disassembly of Optional Pilot Operated Solenoid Valves .....	5-15
Replacing Immersion Heaters .....	5-16
Removing the Pump.....	5-18

## 6-1 Troubleshooting

Before Beginning .....	6-2
A Few Words of Caution.....	6-2
Identifying the Cause of a Problem .....	6-3
Controller Warnings and Alarms .....	6-4
RQT Standard Control Alarms .....	6-4
RQT Standard Control Alarm/Warnings.....	6-15
RQT Standard Control Warnings.....	6-24
Checking the RTD .....	6-26

## Appendix A

We're Here to Help.....	A-1
How to Contact Customer Service .....	A-1
Before You Call.....	A-1

## Appendix B

User Parameters.....	B-1
Factory Parameters.....	B-5
Diagnostics .....	B-7
PID Parameters .....	B-11

## Appendix C

Plumbing Diagrams .....	C-1
-------------------------	-----

*This page intentionally left blank.*

# Introduction

---

Purpose of the User Guide..... 1-2

How the Guide is Organized ..... 1-2

Your Responsibility as a User ..... 1-2

ATTENTION: Read This So No One Gets Hurt..... 1-3

Zero Energy State (ZES) ..... 1-4

# Purpose of the User Guide

This User Guide describes the Thermal Care RQT Standard temperature control unit and explains step-by-step how to install and operate this equipment.

Before installing this product, please take a few moments to read the User Guide and review the diagrams and safety information in the instruction packet. You also should review manuals covering associated equipment in your system. This review won't take long, and it could save you valuable installation and operating time later.

# How the Guide is Organized

Symbols have been used to help organize the User Guide and call your attention to important information regarding safe installation and operation.



Symbols within triangles warn of conditions that could be hazardous to users or could damage equipment. Read and take precautions before proceeding.



Numbers indicate tasks or steps to be performed by the user.



A diamond indicates the equipment's response to an action performed by the user or a situation.



An open box marks items in a checklist.



A circle marks items in a list.



Indicates a tip. A tip is used to provide you with a suggestion that will help you with the maintenance and the operation of this equipment.



Indicates a note. A note is used to provide additional information about the steps you are following throughout the manual.

# Your Responsibility as a User

You must be familiar with all safety procedures concerning installation, operation, and maintenance of this equipment. Responsible safety procedures include:

- Thorough view of this User Guide, paying particular attention to hazard warnings, appendices, and related diagrams.
- Thorough review of the equipment itself, with careful attention to voltage sources, intended use, and warning labels.
- Thorough review of instruction manuals for associated equipment.
- Step-by-step adherence to instructions outlined in this User Guide.



# ATTENTION: Read This So No One Gets Hurt

We design equipment with the user's safety in mind. You can avoid the potential hazards identified on this machine by following the procedures outlined below and elsewhere in the User Guide.



**WARNING: Improper installation, operation, or servicing may result in equipment damage or personal injury.**

This equipment should be installed, adjusted, and serviced by qualified technical personnel who are familiar with the construction, operation, and potential hazards of this type of machine.

All wiring, disconnects, and fuses should be installed by qualified electrical technicians in accordance with electrical codes in your region. Always maintain a safe ground. Do not operate the equipment at power levels other than what is specified on the machine serial tag and data plate.



**WARNING: Voltage Hazard**

This equipment is powered by three-phase alternating current, as specified on the machine serial tag and data plate.

A properly sized conductive ground wire from the incoming power supply must be connected to the chassis ground terminal inside the electrical enclosure. Improper grounding can result in severe personal injury and erratic machine operation.

Always disconnect and lock out the incoming main power source before opening the electrical enclosure or performing non-standard operating procedures, such as routine maintenance. Only qualified personnel should perform troubleshooting procedures that require access to the electrical enclosure while power is on.



**WARNING: Compressed Air Hazard**

If you use compressed air, you must wear eye protection and observe all OSHA and other safety regulations pertaining to the use of compressed air. Bleed off pressure before servicing equipment.



**CAUTION: Hot Surfaces**



Surface temperatures inside the RQT Standard temperature control unit can exceed 250°F {121°C}. Always allow the unit to cool below 100°F {38°C} before opening, servicing, or disassembling the unit.

## Zero Energy State (ZES)



**CAUTION:** Before performing maintenance or repairs on this product, you should disconnect and lockout electrical power sources to prevent injury from unexpected energizing or start-up.

During maintenance, it is essential that the system be put into a state which eliminates the possibility of components making an unexpected and dangerous movement. This procedure is typically referred to as lockout. After all energy sources have been neutralized, the system is in the zero mechanical state (ZMS). This provides maximum protection against unexpected mechanical movement.

The lockout procedure must include all energy sources:

- Electrical power supply
- Compressed air supply
- Potential energy from suspended parts
- Pressurized process fluid loop
- Cooling fluid supply
- Cooling fluid return
- Stored thermal energy
- Any other source that might cause unexpected mechanical movement or energy release

The following is a recommended Zero Energy State procedure which must be followed prior to any inspection, or maintenance of the TCU.

- 1 Turn off the all devices attached to the RQT Standard temperature control unit.**
- 2 Perform the proper shutdown sequence to the connected equipment** and allow all components (internally and externally) to adequately cool.
- 3 Disconnect and lock out the primary electrical supply feeding all attached components.**



**WARNING:** Before removing lockout devices and returning switches to the ON position, make sure that all personnel are clear of the machine, tools have been removed and all safety guards reinstalled.

- 4 Disconnect and lock out the compressed air supply** (if equipped).
- 5 Isolate the RQT Standard temperature control unit from other fluids in the system**, such as the main process loop and the cooling fluid supply and return.
- 6 Bleed off fluid pressure that may be present in the various fluid containing portions of the RQT Standard temperature control unit**, keeping in mind that pressure can be the result of increased temperatures.

## Description

---

What is the RQT Standard .....	2-2
Typical Applications.....	2-2
How the RQT Standard Direct Injection Works .....	2-5
RQT Standard Control Features vs RQT Advanced & RQT Premium.....	2-6
Specifications: RQT Standard.....	2-7

# What is the RQT Standard

The RQT Standard circulates water at a temperature higher than the available water supply, to add or remove heat as needed to maintain a uniform temperature setpoint in the process.

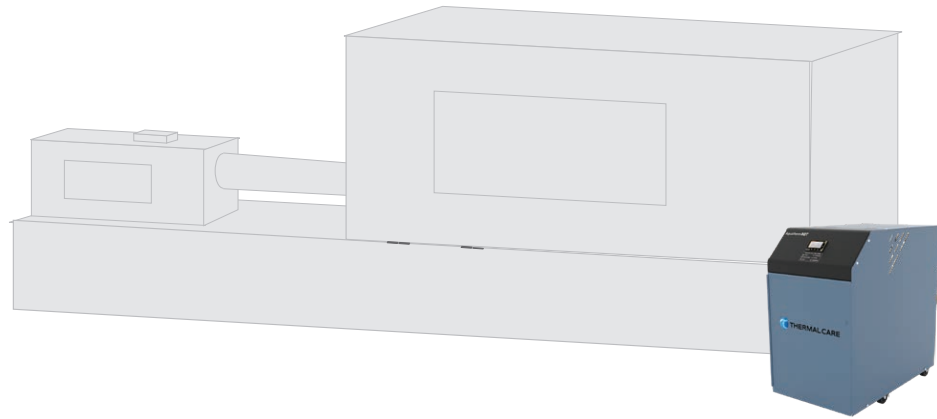

The RQT Standard is available in single zone configuration for process heating and cooling.

## Typical Applications

The best model for your application depends on the process temperature you need to maintain and the quality of the cooling water supply.

RQT direct injection (DI) models control the temperature by discharging heated process water or adding cooling water directly from the water supply. DI models are designed for:

- Process temperatures up to 250°F {121°C}.
- Use with chiller water or properly treated and filtered tower or city water.

Check to make sure all piping connections are secure and that all lines are suitable for water or the coolant in the system at the maximum setpoint temperature and cumulative pressure rating of the maximum pump pressure and the unit fill fluid pressure

Make sure that the cooling source is the appropriate temperature and pressure for your application. In most cases, the cooling source is between 40°F and 85°F. The cooling source fluid pressure must be above the setpoint of the pressure switch in order for the unit to start. For most applications, the design cooling source supply pressure is between 25 psi and 50 psi and must not exceed 90 psi for the 2HP module (95 psi for the 3/4 HP model). If the total pressure in the unit exceeds 135 psi, the pressure relief valve in the unit will open. If this becomes an issue, install a pressure-regulating valve (available from our Parts Department) on the supply line to help regulate the pressure to ensure it does not exceed the pressure rating of the pressure relief valve. For further assistance in installing a pressure-regulating valve, please contact our Customer Service Department.

## How the RQT Standard Direct Injection Works

Direct injection models maintain the process temperature by electrically heating and/or injecting cool water supplied to the RQT Standard by a chiller, tower, or other water source.

- 1** The temperature of the process fluid is measured as it leaves the unit's primary heater tank. The fluid then flows through the "To Process" line to the mold or process. The fluid returns to the unit through the "From Process" line for reheating or cooling.
- 2** The temperature of the process fluid may be measured as it flows into the mixing tank through the "From Process" line.
- 3** If the "To Process" temperature is above the setpoint value, the cooling valve opens. Cool water enters the bottom of the mixing tank via the "Cooling In" line. Warm water flows out of the top of the tank via the "Cooling Out" line.

 **NOTE:** The "From Process" can also be configured as a controlling source.

If the "To Process" temperature is below the setpoint, the heater elements inside the heater tank are energized.

- 4** The pump moves water from the mixing tank into the heater tank. Pressure is measured before and after the pump with pressure gauges.

*See Appendix C for plumbing diagrams.*

# RQT Standard Control Features vs RQT Advanced and RQT Premium Units

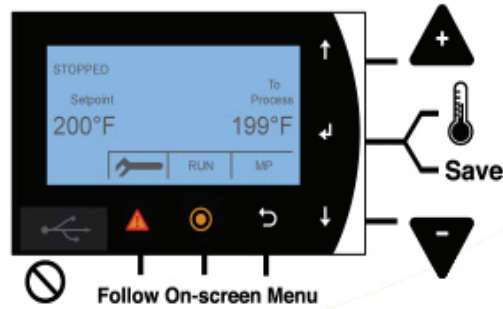

Use the charts below to compare RQT control options and choose the one perfect for your application.

## Control features on the RQT Standard

Model	RQT Standard
Direct Injection	●
Closed Circuit - Common Source	
Closed Circuit - Separate Source	
<b>Construction</b>	
Standard Pump Range	3/4 or 2 Hp
Standard Heater Range	12 kW
Cast Heater / Pump	●
Incoloy Heaters	●
Silicon Carbide Seals	●
Pressure Gauges	●
Pressure Transducer	
Solid State Heater Relays (SSRS)	
<b>Controls</b>	
PID Control	●
Setpoint / Actual Display	●
Password Protection	
Modbus-RTU via RS-485	
Modbus-TCP via Ethernet	
SPI RS-485 Interface	
OPC-UA via Ethernet	
Retransmit Process Temp	
Auto Restart Capability	
Mold Purge (Factory Installed)	○
Phase Detection Circuit	○
Choice of Control Points	●
Seal Saver/Auto Cool Stop	
<b>Status / Alarm Lights</b>	
Audible Alarm	
Strobe Light	
Alarm Dry Contacts	
Remote RTD Support	
Trending	

● Standard  
○ Optional

● Purge On/Off button included on control.

● Phase detection indicates incorrect pump rotation or an open electrical leg.

● Control temperature based on temperature at process supply or return points, or an average of the two points.

## Control features on the RQT Advanced and RQT Premium

Model	RQT Advanced	RQT Premium
Direct Injection	●	●
Closed Circuit - Common Source	○	○
Closed Circuit - Separate Source		○
<b>Construction</b>		
Standard Pump Range	3/4 to 10 Hp	3/4 to 10 Hp
Standard Heater Range	0 to 48 kW	0 to 48 kW
Cast Heater / Pump	●	●
Incoloy Heaters	●	●
Silicon Carbide Seals	●	●
Pressure Gauges		
Pressure Transducer	●	●
Solid State Heater Relays (SSRS)	○	○
<b>Controls</b>		
PID Control	●	●
Setpoint / Actual Display	●	●
Password Protection		●
Modbus-RTU via RS-485	●	
Modbus-TCP via Ethernet	○	●
SPI RS-485 Interface		○
OPC-UA		●
Retransmit Process Temp	● (0-10 VDC)	●
Auto Restart Capability	●	●
Mold Purge (Factory Installed)	○	○
Phase Detection Circuit	○	●
Choice of Control Points	●	●
Seal Saver/Auto Cool Stop	●	●
<b>Status / Alarm Lights</b>		
Audible Alarm	●	●
Strobe Light	○	○
Alarm Dry Contacts	○	○
Remote RTD Support	●	●
Trending		●

# Specifications: RQT Standard

Models	RQT Standard
<b>Performance characteristics</b>	
Minimum setpoint temperature °F {°C}	40 {4}
Maximum setpoint temperature °F {°C}	250 {121}
Minimum operating temperature °F {°C}	Approximately 20° {11°} above the cooling water inlet temperature
Standard cooling valve size inches {mm} Cv	solenoid valve-3/8 {9.5} (Cv=2.5)
Available pump sizes	0.75, 2 {0.56, 1.49 kW}
Available heater sizes	12 kW

Pump performance - Consult factory for pump performance characteristics at other operating points.		
Pump	3/4 Hp {0.56 kW}	2 Hp {1.49 kW}
Nominal flow gpm {lpm}	50 {189}	75 {284}
Pressure @ nominal flow psi {kg/cm²}	20 {1.4}	30 {2.1}

Dimensions inches {mm}	
Standard cabinet, not including any connections	
A - Height	24.98 {634}
B - Width	14.09 {358}
C - Depth	24.09 {612}

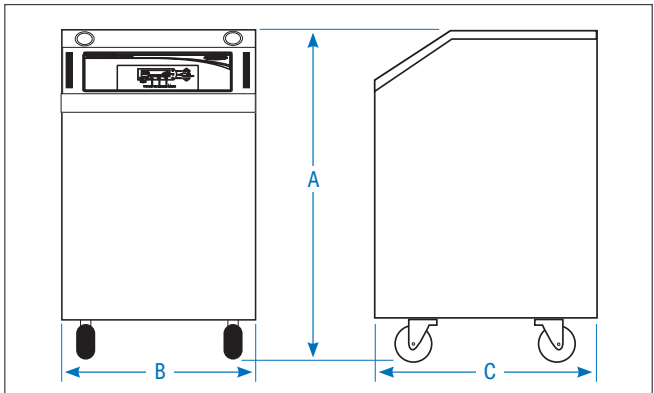

Water connections	
All models NPT inches {female}	
To/From process	1.50
Cooling water in/out	1.00

Shipping weight ranges lb {kg} Weights vary depending on selected options, voltage and pump HP		
Single Zone		
Pump	Minimum	Maximum
0.75 Hp {0.56 kW}	estimated 240 {109}	estimated 325 {147}
2 Hp {1.49 kW}	estimated 250 {113}	estimated 338 {153}

Total full load amps per zone* Standard voltage is 460 volts, 3 phase, 60 Hz.					
Heater					
Voltage	208-230/3/60		400/3/50	460/3/60	575/3/60
	208	230			
Pump size					
0.75 Hp {0.56 kW}	30.3	33.2	19.2	16.6	13.4
2.0 Hp {1.49 kW}	33.3	36.1	21.4	18.1	14.5

**Specification Notes**

\* FLA data for reference purposes only. Does not include any options or accessories on equipment. For full FLA detail for power circuit design of specific machines and systems, refer to the electrical diagrams of the equipment order and the nameplate applied to the machine.

Consult factory about your application prior to using a check valve on the Cooling Water Inlet of your RQT Standard controlled unit.

Specifications may change without notice. Consult factory for the most current information.

*This page intentionally left blank.*



# Installation

---

Unpacking the Boxes .....	3-2
Preparing for Installation .....	3-3
Installation - Electrical .....	3-6
Connecting Process and Water Supply Lines <u>Without</u> Purge.....	3-7
Connecting Process and Water Supply Lines <u>With</u> Purge.....	3-8
Connecting the Main Power Source.....	3-9
Testing the Installation .....	3-10
Initial Setup .....	3-11
RQT Standard Control Setup.....	3-11
Changing Temperature Units .....	3-12
Additional RQT Standard Control Setup.....	3-12

# Unpacking the Boxes

RQT Standard models come fully assembled. If it was specified at the time of the order, the optional purge valve is factory-installed.



## **CAUTION: Lifting**

To avoid personal injury or damage to the RQT Standard, lift the unit using a forklift or hoist with straps that have been positioned at the center of gravity.



**WARNING:** If using straps, be sure to use a spreader bar or equivalent so the top sheet metal of the RQT Standard isn't inadvertently pinched due to the lifting action.

 **NOTE:** If the temperature control unit is stored prior to installation, it is important to protect it from damage. Blow out any water from the unit to protect it from damage from freezing. Cover the equipment to keep dirt and debris from accumulating on it. Units should not be stored in areas warmer than 145°F (63°C).



- 1 Carefully remove the RQT Standard** and components from its shipping containers.
- 2 Remove all packing material**, protective paper, tape, and plastic. Compare contents to the shipping papers to ensure that you have all the parts.
- 3 Carefully inspect all components** to make sure no damage occurred during shipping. Check all wire terminal connections, bolts, and any other electrical connections, which may have loosened during shipping.
- 4 Record serial numbers and specifications** in the blanks provided on the back of the User Guide's title page. This information will be helpful if you ever need service or parts.
- 5 You are now ready to begin installation.** See *Installation Section entitled, Preparing for Installation.*

 **NOTE:** Beware that the room-temperature water frequently contains a surprisingly large quantity of dissolved air within it and this air will separate from the water once heated to an elevated temperature. Additional provisions may have to be made to remove this air from the fluid loop, as it will inhibit heat transfer, and damage the pump and heater if it comes out of the fluid.

# Preparing for Installation

The RQT Standard is easy to install, if you plan the location and prepare the area properly.

**⚠ WARNING: Improper installation, operation, or servicing may result in equipment damage or personal injury.**

This equipment should only be installed, adjusted, and serviced by qualified technical personnel who are familiar with the construction, operation, and potential hazards of this type of machine.

All wiring, disconnects, and fuses should be installed by qualified electrical technicians in accordance with electrical codes in your region. Always maintain a safe ground. Do not operate the equipment at power levels other than what is specified on the machine serial tag and data plate.

**1 Position the RQT Standard as close to the process machine as possible.**

**2 Make sure the installation area provides:**

- A three-phase power source supplying the correct current for your RQT Standard model.** Check the serial tag on the unit for required voltage, phase, frequency, and full load amps. Check the electrical prints for the disconnect fuse size and minimum wire connection size. All wiring should be completed by qualified personnel and should comply with your region’s electrical codes.
- Compressed, dry air (<100psi)** if your RQT Standard is equipped with the Mold Purge option.
- A clean, well-ventilated environment.** The room temperature should not exceed 104° F {40° C} with 95% non-condensing humidity and should not fall below 32° F {0° C}.
- Minimum clearance for safe operation and maintenance.** The diagram at the right shows minimum clearance for operation. You also need enough clearance in rear for water hookups. For maintenance, you should move the RQT Standard to provide at least 36 inches {91 cm} on any side of the RQT Standard. Additionally, your required electrical codes may require a larger service area in front of the electrical panel.
- A source of water for cooling.** City, tower or chiller water may be used, as long as the supply pressure is at least 25 psi and not more than 90 psi for 2 HP models (95 psi for 3/4 HP models).
- Check to make sure all piping connections are secure and that all lines are suitable for water or the coolant** in the system at the maximum setpoint temperature and cumulative pressure rating of the maximum pump pressure and the cooling water supply pressure, or the nameplate rating of the pressure relief valve (150psi), whichever is greater.
- A location to mount an external three-phased, fused, and grounded electrical disconnect.**
- Lockable isolation devices for all utilities,** including electrical disconnect, cooling water line valves, and compressed air supply disconnect and bleed-off.

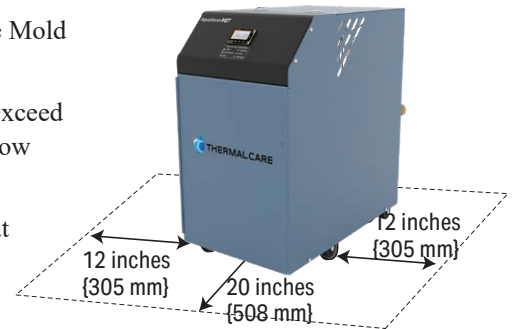
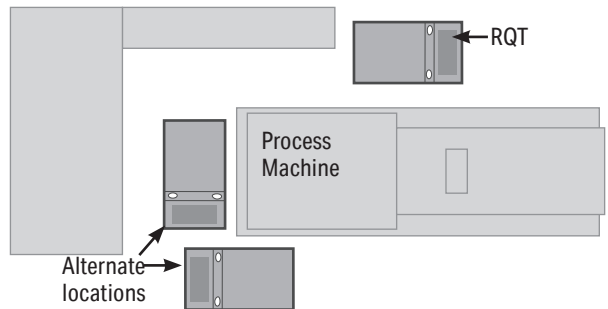

Pump HP	Max Cooling (PSI)
3/4	95
1	90
2	90
3	85
5	75
7.5	65
10	50

**NOTE:** If your cooling water pressure exceeds the cooling water pressure chart referenced previously, install a pressure-regulating valve before the cooling inlet.

## Preparing for Installation (Continued)

- ❑ **Make sure that the cooling source is the appropriate temperature and pressure for your application.** In most cases, the cooling source is between 40°F {4°C} and 85°F {29°C}. The cooling source fluid pressure must be above the setpoint of the pressure switch in order for the unit to start. For most applications, the design cooling source supply pressure is between 25 psi and 50 psi, not to exceed 90 psi for 2 HP models (95 psi for 3/4 HP models). The pressure relief valve is located on the “From Process” side of the pump and will start to discharge if the pressure exceeds 135 psi. If this becomes an issue, install a pressure-regulating valve (available from our Parts Department) on the supply line to help regulate the pressure to ensure it does not exceed the pressure rating of the pressure relief valve. For further assistance in installing a pressure-regulating valve, please contact our Customer Service Department.

### System Fill Water Chemistry Requirements

The properties of water make it ideal for heat transfer applications. It is safe, non-flammable, non-poisonous, easy to handle, widely available, and inexpensive in most industrialized areas.

When using water as a heat transfer fluid it is important to keep it within certain chemistry limits to avoid unwanted side effects. Water is a “universal solvent” because it can dissolve many solid substances and absorb gases. As a result, water can cause the corrosion of metals used in a cooling system. Additionally, dissolved minerals naturally present in tap water will precipitate out onto the system plumbing at elevated fluid temperatures, forming scale. The life giving properties of water can also encourage biological growth that can foul heat transfer surfaces.

To avoid the unwanted side effects associated with water cooling, proper chemical treatment and preventive maintenance is required for continuous plant productivity.

### Unwanted Side Effects of Improper Water Quality

- Corrosion
- Scale
- Fouling
- Biological Contamination

### Cooling Water Chemistry Properties

- Electrical Conductivity
- pH
- Alkalinity
- Total Hardness
- Dissolved gases

## Preparing for Installation (Continued)

The complex nature of water chemistry requires a specialist to evaluate and implement appropriate sensing, measurement and treatment needed for satisfactory performance and life. The recommendations of the specialist may include filtration, monitoring, treatment and control devices. With the ever-changing regulations on water usage and treatment chemicals, the information is usually up-to-date when a specialist in the industry is involved. The table below shows the list of water characteristics and quality limitations.

### Fill Water Chemistry Requirements

Water Characteristic	Quality Limitation
Alkalinity (HCO <sub>3</sub> <sup>-</sup> )	70-300 ppm
Aluminum (Al)	Less than 0.2 ppm
Ammonium (NH <sub>3</sub> )	Less than 2 ppm
Chlorides (Cl <sup>-</sup> )	Less than 300 ppm
Electrical Conductivity	10-500µS/cm
Free (aggressive) Carbon Dioxide (CO <sub>2</sub> ) <sup>†</sup>	Less than 5 ppm
Free Chlorine(Cl <sub>2</sub> )	Less than 1 PPM
HCO <sub>3</sub> <sup>-</sup> /SO <sub>4</sub> <sup>2-</sup>	Greater than 1.0
Hydrogen Sulfide (H <sub>2</sub> S)	Less than 0.05 ppm
Iron (Fe)	Less than 0.2 ppm
Manganese (Mn)	Less than 0.1 ppm
Nitrate (NO <sub>3</sub> <sup>-</sup> )	Less than 100 ppm
pH	7.5-9.0
Sulfate (SO <sub>4</sub> <sup>2-</sup> )	Less than 70 ppm
Total Hardness (dH) <sup>k</sup>	4.0-8.5

<sup>†</sup> Dissolved carbon dioxide calculation is from the pH and total alkalinity values shown below or measured on the site using a test kit. Dissolved Carbon Dioxide, PPM = TA x 2<sup>[(6.3-pH)/0.3]</sup> where TA = Total Alkalinity, PPM as CaCO<sub>3</sub>

### Recommend Glycol Solutions

Chilled Water Temperature	Percent Glycol By Volume
50°F (10°C)	Not required
45°F (7.2°C)	5 %
40°F (4.4°C)	10 %
35°F (1.7°C)	15 %
30°F (-1.1°C)	20 %
25°F (-3.9°C)	25 %
20°F (-6.7°C)	30 %



**CAUTION:** When your application requires the use of glycol, use industrial grade glycol specifically designed for heat transfer systems and equipment. Never use glycol designed for automotive applications. Automotive glycols typically have additives engineered to benefit the materials and conditions found in an automotive engine; however, these additives can gel and foul heat exchange surfaces and result in loss of performance or even failure of the chiller. In addition, these additives can react with the materials of the pump shaft seals resulting in leaks or premature pump failures.



**WARNING:** Ethylene Glycol is flammable at higher temperatures in a vapor state. Carefully handle this material and keep away from open flames or other possible ignition sources.

## Preparing for Installation (Continued)

### 3 Install plumbing for process and cooling lines.

You will need two 1½-inch NPT male fittings for the process inlet and outlet and two 1-inch NPT male fittings for the cooling inlet and outlet. Larger line sizes are acceptable as long as they are reduced at the temperature control unit connections. Smaller process line sizes may be used if flowrate does not need to be maximized.

Contact Thermal Care for more information about recommendations for your product.

## Installation - Electrical

All wiring must comply with local codes and the National Electric Code (NEC). Full Load Amperes (FLA) and other unit electrical data are on the unit nameplate. A unit specific electrical schematic ships with the unit. A qualified individual should measure each leg of the main power supply voltage at the main power source. Voltage must be within the voltage utilization range given on the drawings included with the unit. If the measured voltage on any leg is not within the specified range, notify the supplier and correct before operating the unit. Voltage imbalance must not exceed two percent. Excessive voltage imbalance between the phases of a three-phase system can cause motors to overheat and eventually fail. Voltage-imbalance is determined using the following calculations:

$$\% \text{Imbalance} = (V_{\text{avg}} - V_x) \times 100 / V_{\text{avg}}$$

$$V_{\text{avg}} = (V1 + V2 + V3) / 3$$

$$V_x = \text{phase with greatest difference from } V_{\text{avg}}$$

For example, if the three measured voltages were 442, 460, and 454 volts, the average would be:

$$(442 + 460 + 454) / 3 = 452$$

The percentage of imbalance is then:

$$(452 - 442) \times 100 / 452 = 2.2 \%$$

This exceeds the maximum allowable of 2%.

There is a terminal block for main power connection to the main power source. The main power source should be connected to the terminal block through an appropriate disconnect switch. There is a separate lug in the main control panel for grounding the unit. Check the electrical phase sequence at installation and prior to start-up. Operation of the unit with incorrect electrical phase sequencing will result in improper pump performance. Check the phasing with a phase sequence meter prior to applying power. The proper sequence should read “clockwise” or “ABC” or “L1, L2, L3” on the meter. If the meter reads “counter-clockwise” or “CBA” or “L3, L2, L1”, open the main power disconnect and switch two line leads on the line power terminal blocks (or the unit mounted disconnect). Do not interchange any load leads that are from the unit contactors or the motor terminals.

 **NOTE:** Thermal Care recommends using a second wrench, sometimes referred to as a “back-up wrench”, to support the piping when making connections to the RQT Standard.

 **NOTE:** Thermal Care recommends that you install an external ball valve on the cooling water inlet of the RQT Standard. This valve is required when the purge valve option is installed. [See Plumbing Diagram in Appendix C.](#)

# Connecting Process and Water Supply Lines Without Purge

The RQT Standard process inlets and outlets must be connected to the plumbing that will circulate the temperature-controlled water or fluid through the process. Cooling water inlets and outlets are connected to the cooling water supply.

- 1 Remove the shipping pipe plug** from the female connections on the back of the RQT Standard.
- 2 Install pipe to the rear of the RQT Standard.** Use male 1½-inch NPT piping for process connections and male 1-inch NPT piping for cooling water connections. Pipe and pipe threads must be clean and new. Clean threads with solvent, removing all oil, grease and dirt. Allow the threads to dry before proceeding.
- 3 Coat the pipe threads with thread sealant.** Follow the sealant manufacturer's directions.
- 4 Connect the male pipe to the appropriate female connection** on the back of the unit. Start by hand until the threads engage, then use a pipe wrench to tighten the connection only enough to prevent leaks. **Do not over-tighten!**

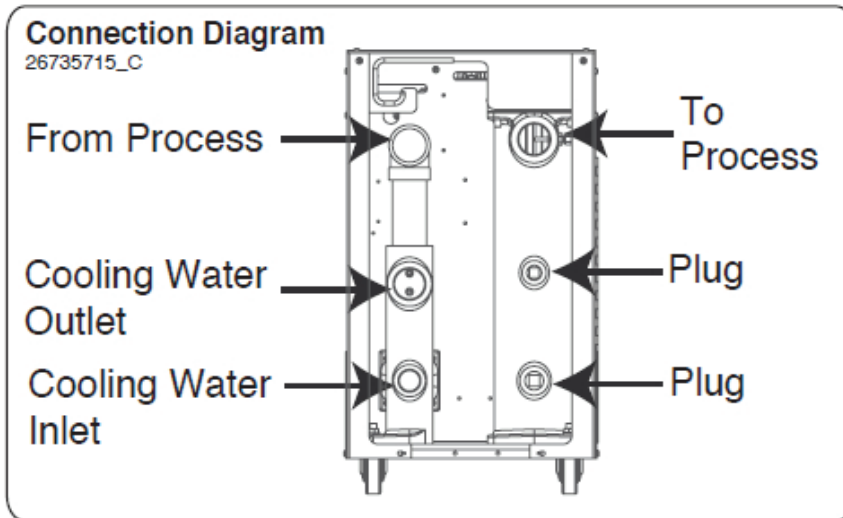

Sample Connection Diagram

Always refer to the connection diagram sticker on the back of your machine for proper connection locations

Tools for Installation:

- Pipe wrench large enough for a 2-inch pipe
- Premium quality Teflon thread sealant

**NOTE:** Thermal Care recommends using a second wrench, sometimes referred to as a "back-up wrench", to support the piping when making connections to the RQT Standard.

**NOTE:** Thermal Care recommends that you install an external ball valve on the cooling water inlet of the RQT Standard. This valve is required when the purge valve option is installed. *See Plumbing diagrams in Appendix C.*

**NOTE:** Beware that the room-temperature water frequently contains a surprisingly large quantity of dissolved air within it and this air will separate from the water once heated to an elevated temperature. Additional provisions may have to be made to remove this air from the fluid loop, as it will inhibit heater transfer, and damage the pump and heater if it comes out of the fluid.

# Connecting Process and Water Supply Lines With Purge

➡ **TIP:** Thermal Care recommends ordering the purge valve with the RQT Standard so that wiring and installation is completed at the factory. However, aftermarket addition of the purge valve is possible.

A mold purge valve is available as an option. This valve quickly evacuates fluid from the process circuit, allowing faster disconnection of the temperature controller from molds and hoses. This valve is controlled like other functions on the RQT Standard, from the temperature controller.

If this option is ordered with the RQT Standard, purge control wiring and installation of the valve on the process line outlet of the unit is completed at the factory. You still must connect process and cooling water inlets and outlets as well as supply non-lubricated compressed air.

- 1 Remove the shipping pipe plug** from the female connections on the back of the RQT Standard.
- 2 Install an external ball valve on the cooling water inlet of the RQT Standard.** This valve is required when a purge valve is used.
- 3 Install pipe to the rear of the RQT Standard.** Use male 1½-inch NPT piping for process connections and male 1-inch NPT piping for water connections. Pipe and pipe threads must be clean and new. Clean threads with solvent, removing all oil, grease and dirt. Allow the threads to dry before proceeding.
- 4 Coat the pipe threads with thread sealant.** Follow the sealant manufacturer's directions.
- 5 Connect the male pipe to the appropriate female connection** on the back of the unit. Connect cooling water lines as indicated on the previous page. Start by hand until the threads engage, then use a pipe wrench to tighten the connection only enough to prevent leaks. **Do not over-tighten!**
- 6 Connect the compressed air supply to the purge valve assembly.** The air pressure should not exceed 100 psi. Thermal Care strongly recommends a lockable air valve be installed in order to effectively lockout this energy source when performing equipment maintenance.

📎 **NOTE:** For information about how to add a purge valve to your RQT Standard if you did not order it equipped that way from the factory, contact Thermal Care Service.

📎 **NOTE:** See "Using the Mold Purge Option" in the Operation section of this user manual.



Sample Graphic

This illustration may not reflect your configuration.



# Connecting the Main Power Source

Before beginning, note the electrical specifications on the serial tag mounted to the side of the unit. The electrical connection must match these specifications with +/- 10% (+/-15% for 400V/50Hz) maximum voltage variance and <2% imbalance. An improper power supply could damage the unit as well as seriously injure an operator. The electrical connection should run through a fused disconnect sized for the amperage noted on the electrical prints and conforming to all local and national codes, including Article 250 of the National Electric Code.



**WARNING: Electrical hazard**



Before performing maintenance or repairs on this product, disconnect and lock out electrical power sources to prevent injury from unexpected energization or start-up. A lockable device must be used to isolate this product from potentially hazardous electricity.



**WARNING: Improper installation, operation, or servicing may result in equipment damage or personal injury.**



This equipment should only be installed, adjusted, and serviced by qualified technical personnel who are familiar with the construction, operation, and potential hazards of this type of machine.

All wiring, disconnects, and fuses should be installed by qualified electrical technicians in accordance with electrical codes in your region. Always maintain a safe ground. Do not operate the equipment at power levels other than what is specified on the machine serial tag and data plate.

- 1 Open the unit's electrical enclosure.** Remove the top panel using a 1/8 inch allen key. The RQT Standard comes from the factory with a knockout for 1/2 inch conduit on the upper left hand corner of the back of the electrical panel (when the electrical panel door is facing away from you).
- 2 Install electrical conduit as desired, along with main power wires inside the conduit, or install the cord.** Knock out on the upper left-hand side of the back of the electrical panel. See electrical prints for recommended wire size.

**NOTE:** If using a flexible cord, secure the wire with a rubber compression fitting or strain relief.

- 3 Connect the power wires to the terminals indicated on the wiring diagram** that came with your machine. The RQT Standard comes pre-wired expecting clockwise (L1-L2-L3) phase rotation. Use a phase rotation meter to verify correct phasing. *See Installation - Electrical earlier in this chapter.*

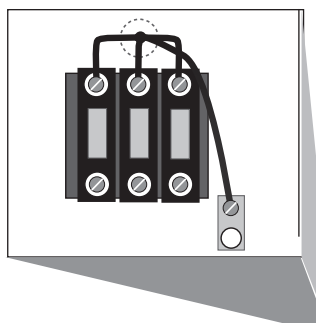

- 4 Check every terminal screw to make sure wires are secure.** Gently tug each wire. If a wire is loose, use a screwdriver or allen wrench to tighten the terminal.
- 5 Connect the ground wire to the grounding lug** shown in the wiring diagram shipped with your unit.
- 6 Use the "J-Hook" at the back of the top panel to keep the power away from hot internal components.**

**Tools Required**

- Flashlight
- 1/8-inch Allen Key
- Medium straight-blade screwdriver
- Phase rotation meter

**IMPORTANT:** Always refer to the wiring diagrams that came with your temperature control unit before making electrical connections. The diagrams show the minimum size main power cable required for your unit, and the most accurate electrical component information.

**IMPORTANT:** Before initiating power to the unit:

Check the system for leaks.

Verify that the voltage, phase, frequency, amperage, disconnect fuse, and minimum wire size meet the specifications.

Verify that resistance to ground on each phase is at least 1 mega-ohm (use a multi-meter, not a megger for this measurement).

# Testing the Installation



**WARNING: Only qualified personnel should perform this procedure.**





Part of this test requires opening the unit while it is energized. Only qualified personnel who have been trained in the use of electrical testing devices and in avoiding the safety hazards involved in safely troubleshooting this type of equipment should perform this test procedure.

- 1 Turn on the cooling water supply and check for leaks and proper water cooling pressure.** If any leaks appear, stop the test and fix the problem before continuing. The cooling water must be at least 25 PSI or the unit will not function on standard 250° F {121°C} units.
- 2 Apply power to the unit.** The temperature controller display illuminates to indicate that the control has power. “Loading...” will be displayed for a few seconds while the control boots up. The control then displays the software version, followed by traditional temperature display on the screen.

**“Low Process Inlet Pres” will be displayed if low water pressure is present.**

- 3 Set the setpoint to 40° using the ↓ button.**
- 4 Check the rotation of the pump.** Remove the top access panel. Press the “RUN” button. When the pump starts after the first (30 seconds) part of the venting sequence, press the “RUN” button again to stop the pump. Verify that the pump rotation matches the direction indicated on the rotation sticker on the side of the pump motor by removing the dust cap on the pump motor in order to check the pump shaft rotation. Pump motor rotation can be viewed at either the back of the motor, or at the exposed shaft where the motor meets the pump.

 **NOTE:** If rotation is incorrect, stop the test and disconnect power to the unit. Open the electrical enclosure and switch any two of the three pump wires on the top of the distribution block. Return to step 2 and check again.

- 5 Replace the top access panel and reinstall fasteners.**
- 6 Press the “RUN”  button to start the unit. If everything is working correctly:**

- The “RUN”  button illuminates amber.
- The unit initiates a venting sequence. Only the cooling valve is active for the first half of the sequence. The pump is additionally active for the final half of the sequence. The display indicates that part of the sequence is active and how much time is left. *Refer to the Maintenance section entitled “Control Vent Timer Adjustment” for more information.*
- Normal operation begins. The heater turns on if the process temperature is below setpoint. The cooling valve is activated if the process temperature is above setpoint.

**If everything tested correctly, proceed to the Initial Setup instructions on the next page.** If something did not work correctly, *refer to the Troubleshooting section of this user guide.*

## Tools Required

- Flashlight
- 1/8” Allen Key

 **NOTE:** If the RQT Standard shuts down after venting and displays “Low Process Inlet Pres” and “LOW PRES PAUSE”, verify that the cooling water supply is connected properly and that the water pressure is at least 25 PSI {1.7 bar}.

# Initial Setup



The temperature controller has been configured at the factory to satisfy most applications, but you can change some settings easily as needed:

## RQT Standard Control Setup

### Menus on the controller:

The controller has information available in six areas. Five of them are user accessible. These are: The Home Screen, the User Parameter Screen, the Diagnostic Screen, the Warning Explanation Screen, and the Alarm Explanation Screen. There is also a Factory Parameter Screen, which has additional parameters that are accessible by Thermal Care Service for troubleshooting. Refer to the Troubleshooting section of this user guide for more information.

### Soft Buttons:

Buttons , , and  are considered “soft” buttons. Their function is variable and is dictated by what is shown above them on the screen.

### Home Screen:

The Home Screen is the normal operating display. The controller always defaults to this page after bootup or when exiting any other menu.



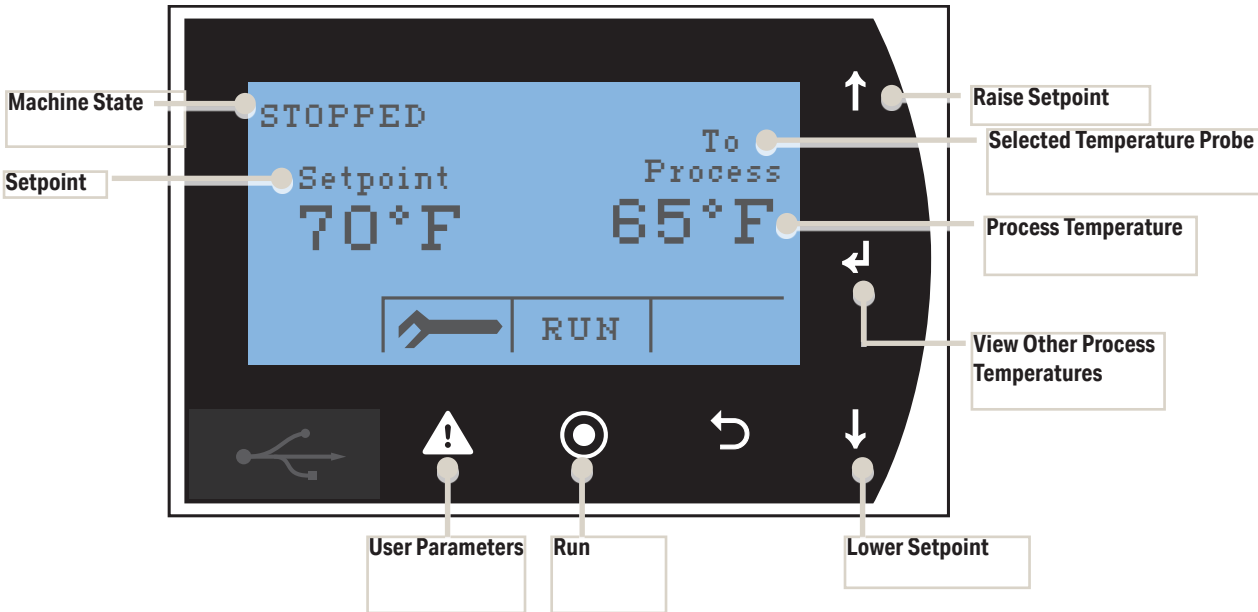

Parameters include:

- Machine State - For the RQT Standard, this will typically be STOPPED / VALVE VENT / VALVE/PUMP VENT / RUNNING / LOW PRES PAUSE.
- Setpoint Temperature - The temperature, shown in units (°F or °C) selected.
- “To Process”, “From Process”, and “To/From Average” - Can be selected to control the loop. The controlling source is displayed as default.









## Changing Temperature Units

The temperature units parameter allows selection of the displayed temperature units. The available choices are degrees Fahrenheit or Celsius.

- 1 Stop the RQT Standard.
- 2 Press the  button to enter the User Parameter Screen.
- 3 Use the “Next”  button to navigate to page 3/6.
- 4 Press  four times to move the cursor to the bottom row that shows “Units:”.
- 5 Use the  or  button to change units.
- 6 The controller will reboot to implement the change.
- 7 Verify that units on the home screen have been successfully changed.

## Additional RQT Standard Control Setup

RQT Standard allows you to select how the unit will measure and control the process temperature. The temperature control point can be selected as the supply temperature probe, the return temperature probe, or the average of the the RQT Standard temperature probes.

- 1 Stop the RQT Standard.
- 2 Press the  button to enter the User Parameter Screen.
- 3 Use the “Next”  button to navigate to page 3/6.
- 4 The cursor should be positioned on the “PV Source” line.
- 5 Use the  or  button to select a different control source.
- 6 Press  to save the new selection.
- 7 Press Exit  to return to the home screen. The new control source will be shown.

# Operation

---

The RQT Standard Control.....	4-2
Home Screen Display .....	4-3
User Parameters.....	4-3
Starting the RQT Standard .....	4-4
Stopping the RQT Standard .....	4-5
Using the Mold Purge Option.....	4-6
Selecting Tuning Parameters.....	4-7
RQT Standard Control Vent Timer Adjustment .....	4-8

# The RQT Standard Control

## Start Button

When not running, press this button to start the TCU. The button illuminates amber when the TCU is running.

## Stop Pump Button

When running, press this button to stop the TCU. The button stops illuminating when the TCU is turned off.

## Process Value Display

The window displays the actual temperature of fluid entering the "To Process" line.

## Enter

The Enter key is used to temporarily view other process temperature measurements.

## Setpoint Value Display

The window displays the fluid temperature setpoint during normal operation.

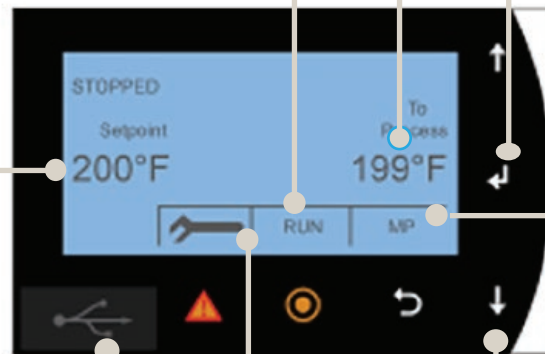

## USB Port

The USB port on the front of the controller is used for factory programming only. Please do not connect it to any devices such as a PC, thumbdrive, camera, etc.

## Menu Access

Press to enter or exit the menu system. Press ↵ to index to the next menu.

**IMPORTANT: Changing menus and parameters incorrectly can result in improper operation of the RQT Standard. Accessing menus and changing parameters is not necessary or possible during normal operation.**



**WARNING:** Shut off the supply to cooling water inlet before purging.

## Raise and Lower

Used to raise/lower the setpoint temperature, index through the operating modes or change other parameter values. Press ↑ to increase a value. Press ↓ to decrease a value.

❖ **TIP:** Press and hold the key for faster scrolling speed.

## Purge (optional)



The purge uses compressed air to clear fluid from the mold and lines before a mold change. Press and hold the purge for three seconds to evacuate all fluid from mold and line. The purge button is inactive when the RQT is running.

## Home Screen Display

The RQT Standard temperature controller uses a menu system to access different operating modes or change system parameters. *Please see the Appendix B-3 for default parameter settings and detailed information on each of these modes and parameters*

## User Parameters

To review or edit the User Parameters menu, press Enter to cycle through units. Use the up and down buttons to select a choice or change a value. These can be accessed by

pushing the  button from the home screen. Use the  button to save and advance to next value. Use the ↑ and ↓ arrow buttons to adjust the parameter.

Use the  and  buttons to navigate to the prior/next parameter screen.

For more information regarding User Parameters, *refer to Appendix B*. These parameters should only be adjusted by experienced individuals with guidance from the Thermal Care Service Department.

# Starting the RQT Standard

Before starting the RQT Standard, verify that the system has been installed correctly for your application. *See the Installation section.*

- 1 Turn on the water supply to the RQT Standard.** The supply pressure must be at least 25 psi for most units. Check for leaks in the cooling water and process fluid lines before continuing.
- 2 Turn on main power to the RQT Standard.**
- 3 If the RQT Standard's process lines were recently reconfigured or you suspect there may be excessive air in the process lines, set the temperature setpoint to 40°F {4.4°C}.** This will provide additional flushing and de-aeration in the process lines via the cooling valve.

- 4 Press “RUN” .** The vent cycle should begin.  
If everything is working correctly:

- The “RUN”  button lights amber and machine status is “VALVE VENT”.
- The unit initiates a venting sequence. The pump starts after “VALVE VENT” is complete and the status becomes “VALVE/PUMP VENT”.
- Normal operation “RUNNING” begins after “VALVE/PUMP VENT” is over. The heater turns on if the actual temperature is below setpoint. The cooling valve is active if the actual temperature is above setpoint.

 **NOTE:** Both venting stages will be skipped if the process temperature is above the vent bypass temperature, and the RQT Standard will consequently start the pump immediately in the “RUNNING” state.

- 5 Set the setpoint to the desired temperature.** Use the ↑ and ↓ keys to increase or decrease the temperature setting.
- 6 If the Fault  LED flashes, refer to the Troubleshooting section for more information.**

 **NOTE:** If the RQT Standard shuts down after venting and displays “Low Process Inlet Pres” and “LOW PRES PAUSE”, verify that the cooling water supply is connected properly and that the water pressure is at least 25 PSI (1.7 bar).



# Stopping the RQT Standard

You must shut down the RQT Standard whenever you:

- Change the water hookups.
- Perform maintenance on the process machine.
- Purge the process circuit of the water or fluid.
- Change any parameters.
- Perform routine or preventive maintenance.
- See an alarm condition that requires troubleshooting.
- Relocate, ship or store the unit.

To shut down the unit during a normal interruption in production process, where no maintenance will be performed:

**1 Press STOP**  .

To shut down the unit to change water hookups:

**2 Change setpoint to 80°F {27°C}** and allow the RQT Standard to cool itself to less than 100°F {38°C}.

**3 Press STOP**  .

**4 Shut off the cooling water supply, and relieve any pressure in the unit** (*see pressure gauge*) by removing the drain plug at the bottom of the heater tank; then drain the unit of all fluid. Remove the plug and the cooling water inlet hose to provide additional draining.

**5 Once the unit is cool, remove the water hookups.**

To shut down the unit for relocation or storage:

**1 Change setpoint to 80°F {27°C}** and allow RQT Standard to cool itself to less than 100°F {38°C}.

**2 Press STOP**  .

**3 Shut off the cooling water supply, and relieve any pressure in the unit** (*see pressure gauge*) by removing the drain plug at the bottom of the heater tank; then drain the unit of all fluid. Remove the plug and the cooling water inlet hose for maximum draining.

**4 Disconnect the power supply and all water feeds.**

In shipment or storage, the RQT Standard can withstand an environment between -40°F {-40°C} and 150°F {65°C} with 95% relative humidity non-condensing as long as all water has been drained from the unit.

# Using the Mold Purge Option





The RQT Standard can be ordered with an optional purge valve, which clears the process lines of fluid using compressed air. The valve is operated by an optional purge button on the temperature controller.

**Mold Purge:**

- Pump must be Off
- Press and hold MP for 3 seconds to initiate Mold Purge



**IMPORTANT:** Before purging the process lines, be sure that the cooling water source feed is closed. If the feed is open and the air line has a higher pressure than the cooling water, air may be injected into the cooling water system. If the cooling water pressure is higher than the air line, cooling water may be injected into the air line.

- 1 If the RQT Standard is running, stop it by pressing STOP .
  - 2 Shut off the cooling water supply valve.
  - 3 Press the “MP”  button for 3 seconds.
    - “PURGING” is displayed.
    - The cooling valve is opened.
    - The purge solenoids are opened.
-  **NOTE:** The maximum purge time can be adjusted on the User Parameters “Mold Purge T/O”. This defines the starting point for the countdown timer shown at the bottom of the purging screen.
- 4 Press the “STOP”  button to stop Mold Purge or simply allow it to timeout.

# Selecting Tuning Parameters

The controller has three pre-configured tuning parameter sets, one of which should allow optimum temperature control. The following is a description of each of the choices available to an operator.

## Slow Responding system:





Select the slow setting “Large” for large systems for parameter “System Size”. More than 80 gallons {303 liters} of water and more than 5,600 lbs {2,540 kg} of steel would be considered a large system. This setting has the smallest proportional band ( $3\Delta^{\circ}\text{F}$  { $1.67\Delta^{\circ}\text{C}$ }), which allows larger changes in the control output when the process temperature is far from setpoint.

## Normal Responding System:

Normal “Normal” is the factory default tuning setting, as it will cover the majority of applications. This setting is appropriate for systems with 10 to 80 gallons {38 to 303 liters} of water and 700 to 5,600 lbs {318 to 2,540 kg} of steel. The default value for the normal proportional band is  $7\Delta^{\circ}\text{F}$  { $3.88\Delta^{\circ}\text{C}$ }.

## Fast Responding system:

Select the fast setting “Small” for small systems for parameter “System Size”. Less than 10 gallons {38 liters} and 700 pounds {318 kg} of steel might be considered a small system. This setting has the largest proportional band ( $15\Delta^{\circ}\text{F}$  { $8.33\Delta^{\circ}\text{C}$ }), which allows a fast response to more desirable deviations between the process variable and setpoint. This system is typical for small RQT Standards with small molds or other process machinery.

- 1 If the RQT Standard is running, stop it by pressing STOP .
- 2 Press the  button to access User Parameters.
- 3 Press the “NEXT”  button to get to screen 5/6, which shows the PID parameters.
- 4 Select “Small”, “Normal”, or “Large” for the parameter “System Size” and then press “Enter” . The additional parameters below will automatically adjust to appropriate values.
- 5 Press “Exit”  when finished.

See “PID” Parameters section in Appendix B and “Manual Tuning Procedure” section in Appendix B.







## RQT Standard Control Vent Timer Adjustment

When the unit starts, i.e. RUN  is pressed, the Vent sequence is initiated. This is to de-aerate the process loop.

The venting sequence is divided into two phases governed by user changeable parameters. In the first phase, the cooling solenoid valve opens for the set venting sequence time, “Valve Vent”. This is followed by a second phase in which the cooling solenoid valve and pump are energized.

The vent sequence is bypassed if the process loop is above the “Vent Bypass” temperature.

To access the Vent Timer setups:

- 1 If the RQT Standard is running, stop it by pressing STOP .
- 2 Access the configuration screen by pressing .
- 3 Press the “NEXT”  button to get to screen 4/6.
- 4 Press “Enter”  to move the cursor to the parameter that you desire to change.
- 5 Use the  and  buttons to change the values if desired.
- 6 Press “Enter”  to save the new value.

 **NOTE:** It is very important for machine durability to de-aerate the process lines before turning on the pump, and especially before energizing the heater. Adjusting these parameters to values that will provide insufficient aeration will damage the RQT Standard and are not covered under the warranty.

# Maintenance

---

Maintenance of Your RQT Standard .....	5-2
Preventive Maintenance Schedule .....	5-2
Accessing the RQT Standard Enclosure .....	5-3
Removing the Pump Motor and Seal .....	5-4
Reassembling the Pump Motor and Seal .....	5-7
Resetting Pump Overload .....	5-9
Replacing Pump Overload .....	5-9
Replacing the PLC .....	5-10
Replacing the Heater Contactor .....	5-11
Replacing the RTD .....	5-12
Repairing Cooling Valves .....	5-13
Disassembly of Optional Direct Acting Solenoid Valves .....	5-14
Disassembly of Optional Pilot Operated Solenoid Valves .....	5-15
Replacing Immersion Heaters .....	5-16
Removing the Pump .....	5-18

# Maintenance of Your RQT Standard

Depending on which features, options, and additions you ordered with your unit, maintenance procedures and necessities may differ from what is shown in this User Guide. Please note that all illustrations, photos, and instructions are based on a typical configuration of a RQT Standard. Always refer to the wiring diagrams and other documentation - including manuals from the manufacturer of any valves, heat exchangers, and parts used on your RQT Standard - when completing any maintenance or troubleshooting tasks.

If you have any questions or concerns about your RQT Standard, feel free to call Thermal Care's Customer Service department for assistance.

## Preventive Maintenance Schedule

RQT Standard water temperature controllers are essentially maintenance-free. However, to maintain the best performance, we recommend the following maintenance schedule.

### Daily or as often as necessary

- Check for leaks in cooling and process lines.**  
Before and during operation, you should inspect the unit and all plumbing lines for leaks. If a leak develops, stop the RQT Standard and repair it.
- Keep the unit and the area around it clean.**  
Check for and remove lint, dust, or other obstructions on the unit, especially around air vent areas. Keep floor around the unit dry. The RQT Standard exchanges air from in front of, underneath, on top and beside the unit, so make sure that nothing is against the front, bottom, top or sides of the unit that would inhibit proper ventilation around the unit.

### Quarterly (every 3 months) or as often as necessary

- Inspect power cords, wires, and electrical connections.**  
Check for loose or frayed wires, burned contacts, and signs of overheated wires. Check exterior power cords to the main power source and from the electrical box to the pump and heating elements. Check the ground wire and RTD connections. Replace any wire that appears damaged or has worn or cracked insulation.

# Accessing the RQT Standard Enclosure

Depending on which features, options, and additions you ordered with your RQT Standard, it may appear different and operate differently from the illustrations and photos shown in this User Guide.



**WARNING: Electrical shock and hot surface hazards.**



Before attempting maintenance of any kind on the RQT Standard, you must stop the unit, disconnect and lockout the main power supply, and allow the unit to cool to less than 100° F {38° C}.

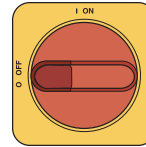

The lockout procedure must include all energy sources:

- Electrical power supply
- Compressed air supply
- Potential energy from suspended parts
- Pressurized process fluid loop
- Cooling fluid supply
- Cooling fluid return
- Stored thermal energy
- Any other source that might cause unexpected mechanical movement or energy release

To access the RQT Standard enclosure:

- 1 Remove the top panel. Use an 1/8-inch Allen Key to remove the (4) screws on the top panel.**
- 2 Remove the right side panel by unscrewing (5) screws. Four screws are located on the side panel while the fifth screw is located on the back.**
- 3 Set the top panel and side panel out of the way for maintenance procedures.**



**NOTE:** Refer to the Zero Energy State (ZES) section of this User Guide for more information.

## Removing the Pump Motor and Seal

### Tools Required

- 9/16-inch wrench
- Flat-blade screwdriver
- 5/8 inch deep socket
- Press for removal of pump seal
- P-80 Lubricant

### Time Required

- 45 Minutes

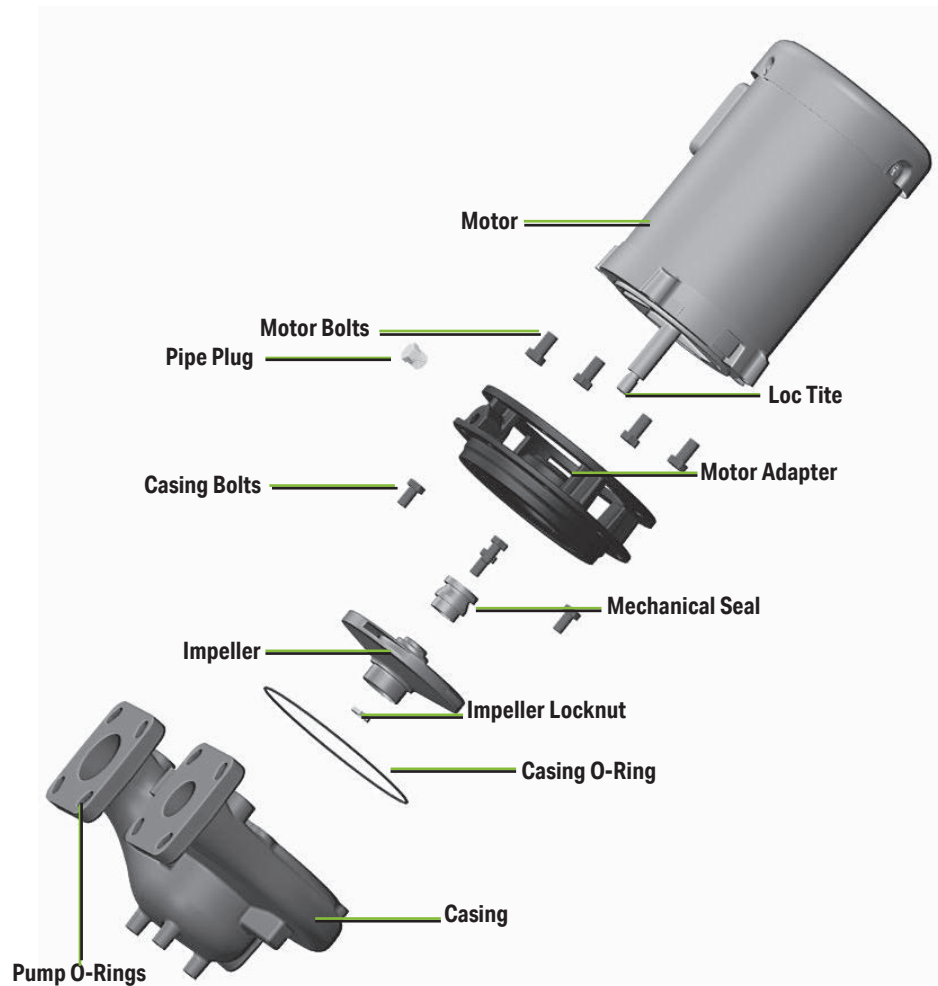

If the pump motor or seal ever needs to be replaced, the following procedure can be used on all models with 3/4 to 2 Hp motors for disassembly:

- 1** Using a 9/16-inch wrench, remove the four (4) casing bolts that hold the motor and impeller adapter assembly to the RQT Standard.
- 2** Remove the motor and adapter from the pump adapter to volute.
- 3** Remove the O-ring between the motor adapter and the casing. Inspect for damage or wear. If in good condition, set aside for re-use. If a new part is needed, contact Thermal Care Parts at 847-966-8560.



## Removing the Pump Motor and Seal (Continued)

- 4** Remove the dust cap from the bell end motor housing to expose the motor shaft.

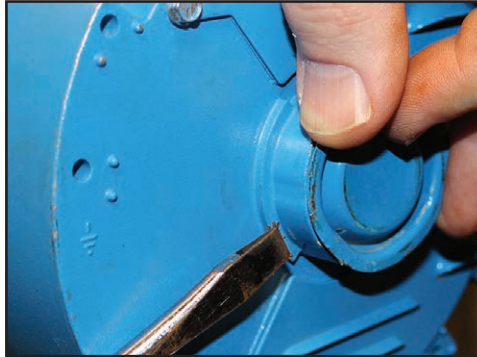

- 5** Using a locking pair of pliers, grip the flat sides of the motor shaft.

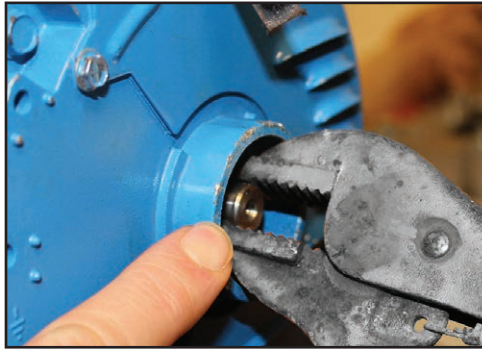

- 6** Remove impeller lock nut using a 5/8 inch deep socket. The lock nut is secured in place with a high performance thread locker. A significant amount of torque will be required to break it free. Use the locking pliers at the other end of the shaft to prevent shaft rotation when removing the lock nut and impeller. Standard clockwise thread is used.



- 7** Unscrew the impeller from the shaft.



(Continued)

## Removing the Pump Motor and Seal (Continued)

- 8** Slide the rotating half of the shaft seal off of the shaft. Be careful not to contaminate, chip, or scratch seal surfaces if it is to be re-used. Set seal half aside for re-use if appropriate.



- 9** Using a 9/16-inch wrench, remove the four (4) casing bolts.



- 10** Slide motor adapter off of motor shaft.

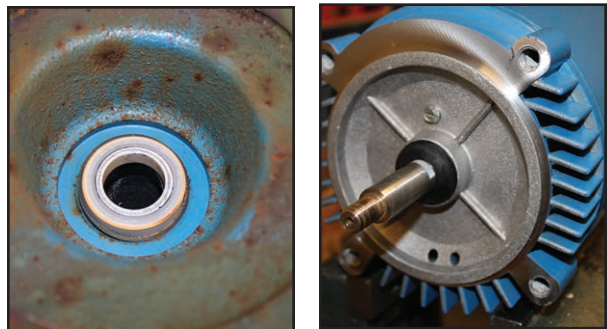

- 11** Press stationary half of pump seal out of motor adapter, being careful not to damage rubber diametral seal or rotating / non-rotating seal interface surface. Set seal half aside for re-use if appropriate.

# Reassembling the Pump Motor and Seal

The following procedure can be used on all models with 3/4 to 2 Hp motors for reassembly:

**1 Gently press stationary half of pump seal into motor adapter** being careful to not damage rotating / non-rotating seal interface surface.



**2 Slide motor adapter assembly on to motor shaft.**

**3 Install and tighten the 4 bolts to 20 ft-lbs {27.12 N·m}. While tightening the bolts, be careful to maintain the motor adapter perpendicular to the shaft.**



**4 Slide the rotating portion of the shaft seal onto the shaft with the spring on the impeller side.**

**5 Lubricate Motor Shaft with P-80 Lubricant. Then slide the rotating portion of the shaft seal on to the shaft with the spring on the impeller side.**



## Tools Required

- 9/16-inch wrench
- Flat-blade screwdriver
- 5/8 inch deep socket
- Blue Loc-Tite<sup>®</sup> (271)
- P-80 Lubricant

## Time Required

- 25 Minutes

(Continued)

## Reassembling the Pump Motor and Seal (Continued)

- 6** Align the impeller and screw on to shaft.



- 7** Place a small amount of Blue Loc-Tite #271 on the shaft end thread.



- 8** Install the impeller jam nut on the shaft, and tighten to 12 ft-lbs {16.27 N·m}. Use a locking pair of pliers to grip the flat side of the shaft at the motor bell end. Re-install dust cap if removed during disassembly.



- 9** Place pump to adapter O-ring on motor adapter. Locate the o-ring as far up the adapter as possible such that it sits tight to the angle formed by the mounting flange.
- 10** Locate the motor and motor adapter assembly on the pump casing. Install the 4 bolts, tightening to 20 ft-lbs {27.12 N·m}.

# Resetting Pump Overload

The pump motor overload is located inside the unit's electrical enclosure.

- 1 Disconnect and lockout the main power.**
- 2 Open the electrical enclosure door.** Turn the screw on the front panel counterclockwise to open.
- 3 Check the overload.** Press the blue button to attempt to reset the overload. If it clicks, the overload was tripped. Verify that the overload trip point is set as specified by the electrical power prints.

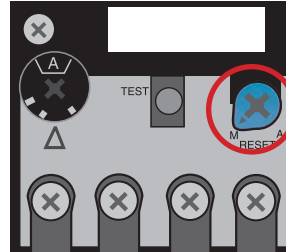

# Replacing Pump Overload

- 1 Disconnect and lockout the main power.**
- 2 Open the electrical enclosure door.** Turn the latch on the front panel counterclockwise to open.
- 3 Locate the pump overload module** attached to the pump motor starter.

- 4 Disconnect the three power leads** from the overload module to the pump motor. Note the color/placement of each lead and label as needed.

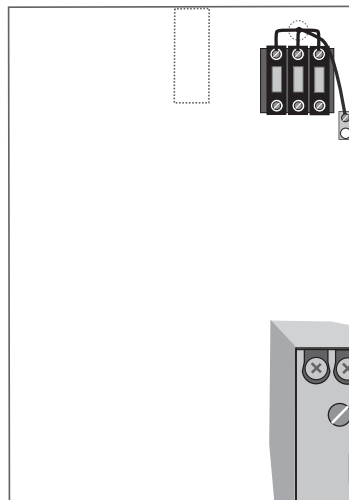

- 5 Disconnect auxiliary wiring on the overload module.**
- 6 Remove the overload module.** Loosen the three screws that connect the overload module to the motor contactor. Pull the overload module down to release it from the contactor.

- 7 Reverse these steps to install the new overload module.**

- 8 Set the module reset mode to M for manual** by rotating the blue button.

- 9 Set the proper FLA trip point.** Trip point will be shown on electrical prints

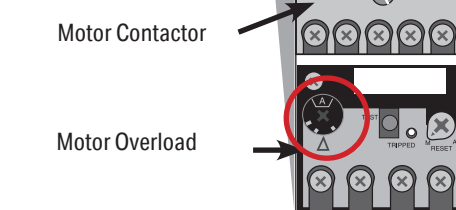

- 10 Push blue reset button on overload** to ensure it is not in the tripped state.

- 11 Verify that pump rotation is correct** (*see Installation section of this manual*).

# Replacing the PLC

The PLC used in the RQT Standard can be removed from the supporting DIN rail for easy replacement.

## To remove the controller:

**IMPORTANT:** Always refer to the wiring diagrams that came with your RQT Standard to locate specific electrical components. Illustrations in the User Guide are intended to be representative only.

- 1 Disconnect and lockout the main power supply.**
- 2 Disconnect all connectors on the rear of the controller.**
- 3 Remove screws attaching DIN rail to standoffs.**
- 4 Remove controller from DIN rail by pulling on plastic release lever.**
- 5 Reverse order to install new controller.** *See Section 3, RQT Standard Control Initial Setup.*

# Replacing the Heater Contactor

 **WARNING: Electrical Shock Hazard**

Only qualified service personnel who have been trained on electrical testing and the procedures for avoiding hazards should diagnose or correct problems.

The heater contactors should be replaced if:

- The controller prompts you to replace the heater contactor because it is worn out.
- You have checked the continuity and found that resistance across the coil equals zero ohms or is an open circuit.
- You have checked continuity of the power legs (with the heater wires disconnected) and find them continuously connected. Or, you have checked continuity across the power legs and find an open circuit even when the coil is energized.

**To replace the heater contactor:**

- 1 Disconnect and lockout the main power.**
- 2 Open the electrical enclosure door.** Turn the latch on the front panel counterclockwise to open.
- 3 Disconnect wires from the heater contactor.** Make sure you label the wires to ensure you can connect them correctly to the new contactor.
- 4 Remove the contactor** by removing the mounting screws that hold it in place.
- 5 Reverse this procedure starting with step 4 to install the new contactor.** Make sure the wires are connected correctly.

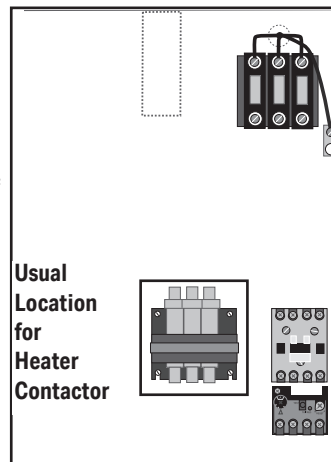

**IMPORTANT:** Always refer to the wiring diagrams that came with your RQT Standard to locate specific electrical components. Illustrations in the User Guide are intended to be representative only.

# Replacing the RTD



**WARNING: Hot Surfaces**



Allow the RQT Standard to cool to below 100° F (38° C) before servicing the unit.

## To replace an RTD:

- 1 Disconnect and lockout the main power.**
- 2 Drain the unit of all water** through the drain plug in the rear of the unit.
- 3 Remove the unit's top panel and open the electrical enclosure.** See section “*Accessing the RQT Standard Enclosure*”.
- 4 Remove the side panels.** See section “*Accessing the RQT Standard Enclosure*”.
- 5 Remove the RTD.** Loosen the compression nut to slide the RTD out of the casing. Disconnect the RTD wires at the terminal strip. Note locations of wires before disconnecting. Remove wire ties.
- 6 Install the new RTD.** Insert the tip of the new RTD at least 1 inch into the tank. Ensure that the tip of the RTD does not make contact with the side wall of the heater tank. Tighten the compression nut. Thread the leads with the wire bundle leading to the electrical enclosure.
- 7 Re-secure RTD wires to the various wire mounts** to keep the wire from contacting the heater housing, pump casing, or motor housing. Wire the RTD wires to secure them within the electrical cabinet.
- 8 Do not trim off extra wire. Leave it coiled like the original RTD so as to not influence circuit resistance. Strip and attach RTD leads to the terminal strip at locations noted in step 5.** Polarity does not matter.

**IMPORTANT:** Always refer to the wiring diagrams that came with your RQT Standard to locate specific electrical components. Illustrations in the User Guide are intended to be representative only.

 **NOTE:** You may want to test the resistance of the new RTD to ensure it aligns with the table in the previous section.

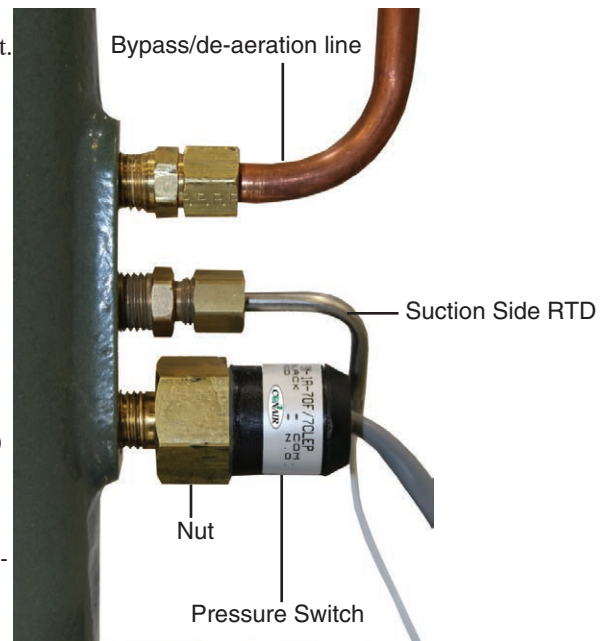
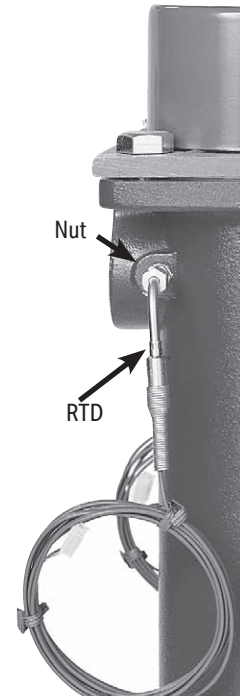



# Repairing Cooling Valves

Every RQT Standard has a valve assembly that controls the cooling water out flow. Occasionally, this valve assembly may need to be cleaned, if clogged with debris, or replaced. The steps below detail this procedure. Cooling valves also are found on the optional purge valve.



## **WARNING: Electrical Shock and Hot Surface Hazard**



Before attempting maintenance of any kind on the RQT Standard, you must stop the unit; disconnect and lockout the main power supply; and allow the unit to cool to 100° F {38° C}.



- 1 Shut off the cooling water in.**
- 2 Drain the unit of all water** through the drain plug in the rear of the unit.
- 3 Observe and record the existing orientation of the valve, its actuator, and the override handle** so that it can be re-installed in the identical orientation.
- 4 Remove the connections to the cooling water out.**
- 5 Disconnect and lockout main power.**
- 6 Disconnect and lockout compressed air** (if equipped).
- 7 Remove the valve from the cooling water out line.**
- 8 Disassemble the valve.** (*See exploded views on next page.*)
- 9 Inspect and clean or repair the valve body assembly.** Remove foreign particles and replace damaged parts as necessary.
- 10 Reassemble the valve and other components.** Reassemble in reverse order. Seal all pipe fittings with pipe sealant. Check that all flows are in the correct direction. Check for leaks before resuming operation.

**IMPORTANT:** Refer to the connection diagram sticker on the back of the machine for correct locations.

# Disassembly of Optional Direct Acting Solenoid Valves

## Disassembly

**Loosen the mounting screws.** The coil assembly, seal, return spring, armature assembly and body can be removed.

## Assembly

### Common to N.C. and N.O.

- 1 Loosen the mounting screws.** The coil assembly, seal, return spring, armature assembly and body can be removed.
- 2 When changing the electrical entry direction, turn the coil assembly in a desired direction to mount it.**
- 3 Push the coil assembly against the body and tighten the screws (using a diagonal pattern) so that there are not gaps between the coil assembly and body.** Tighten the screws in the order of “1-> 2 -> 3 -> 4 -> 1 -> 2 -> 3 -> 4”.

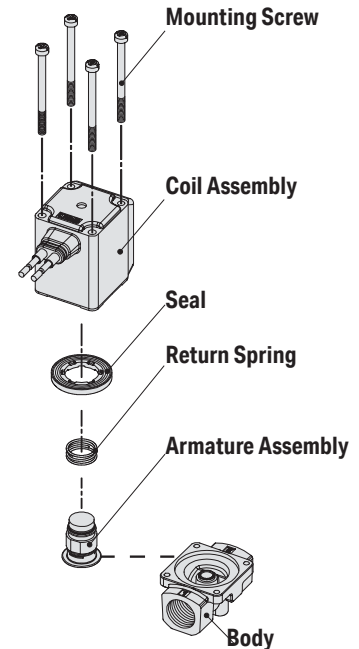

## Proper Tightening Torque

267201-01 & 267201-02	0.37 lbf ft {0.5 N·m}
All others	0.52 lbf ft {0.7 N·m}

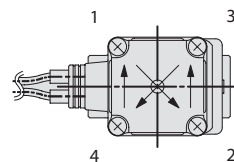
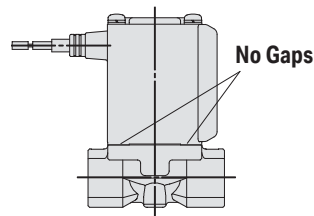

**Tighten Screws two or more rounds diagonally.**

- 4 After tightening the screws, make sure that there are no gaps between the coil and body.**
- 5 After the disassembly and assembly have been completed, make sure that no leak occurs from the seal.** Additionally, when restarting the valve, make sure that the valve operates correctly.

# Disassembly of Optional Pilot Operated Solenoid Valves

**NOTE:** Within the valve body and coil assembly there are no user serviceable parts.

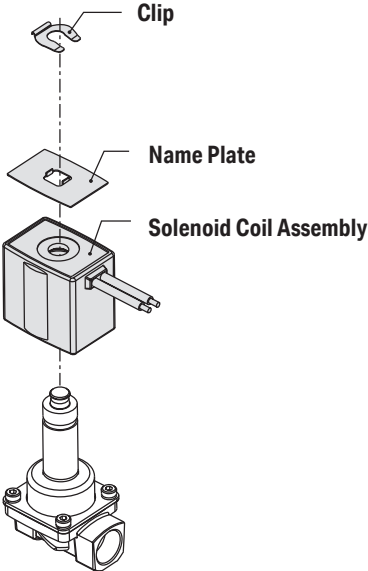

# Replacing Immersion Heaters



**WARNING:** Electrical Shock and Hot Surface Hazard



Before attempting maintenance of any kind on the RQT Standard, you must stop the unit; disconnect and lockout the main power supply; and allow the unit to cool to 100°F {38°C}.



- 1 Disconnect and lockout the main power.**
- 2 Remove the top panel of the RQT Standard.** *See section “Accessing the RQT Standard Enclosure”.*
- 3 Remove the heater cap.** Use a Phillips screwdriver to remove the heater connection box lid.
- 4 Remove the heater wiring harness.** Label the wiring layout of the heater terminals; wires are labeled as 2T1, 2T2, 2T3 and GND.

Record the position of bus links, jumpers, and feed wires so they can be replaced in exactly the same manner on the replacement heater.

Then unscrew the nuts on the cable connectors and remove the wires.

- 5 Shut off the cooling water in.**
- 6 Drain the RQT Standard by removing the drain plug located at the bottom of the heater tank.**
- 7 Remove the four bolts that hold the heater element in place.** Use a 9/16-inch socket.

**IMPORTANT:** Always refer to the wiring diagrams that came with your RQT Standard to locate specific electrical components. Illustrations in the User Guide are intended to be representative only.

## Replacing Immersion Heaters (Cont'd)

- 8** Lift the heating element out of the heater tank. Lift the element straight up.

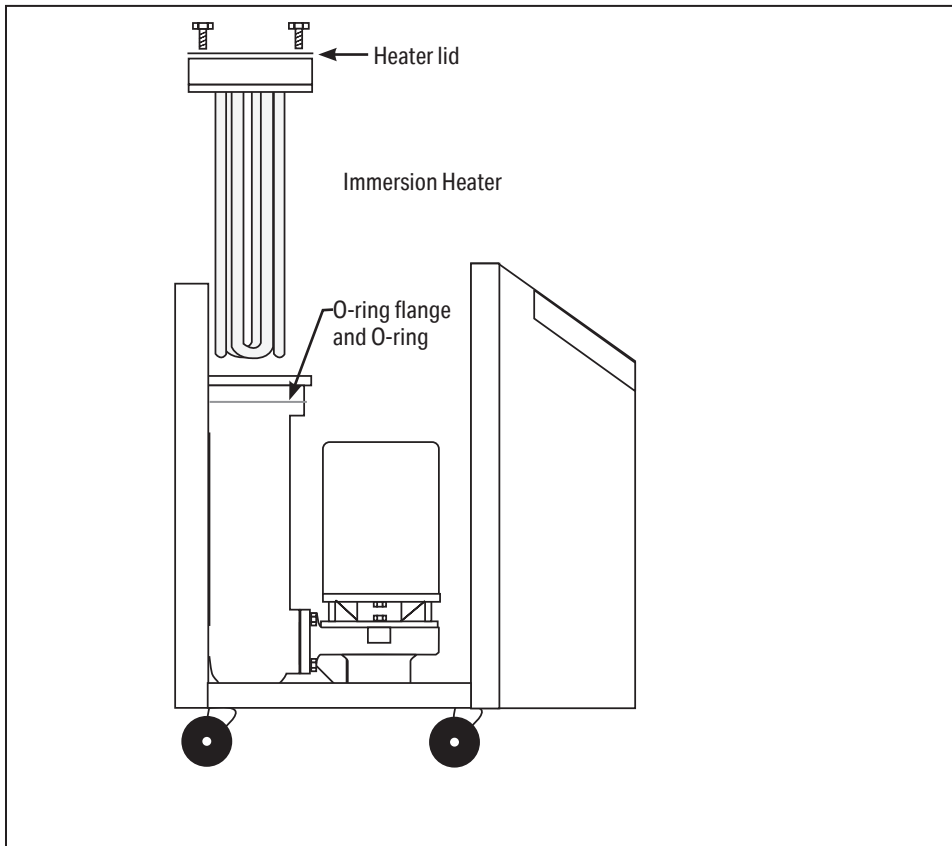

**NOTE:** Illustration for reference only. May not represent current design.

- 9** Clean the heater tank. Remove any rust or solids that may have built up before inserting the heater elements.
- 10** Replace the heater O-ring if it is worn or cracked.
- 11** Clean the O-ring flange or replace it.
- 12** Reverse these steps to install the new heater element and reassemble the unit.

**IMPORTANT:** Note heater orientation - grounding bolt location is crucial to proper operation. Heater ground should be at the back of unit. Heater orientation should be such that the ground is located at the rear most portion of the RQT Standard (opposite the open knockout of the electrical box).

## Removing the Pump



**WARNING: Electrical Shock and Hot Surface Hazard**



Before attempting maintenance of any kind on the RQT Standard, you must stop the unit; disconnect and lockout the main power supply; and allow the unit to cool to 100° F (38° C).



 **NOTE:** Refer to the Zero Energy State (ZES) section of this User Guide for more information.

- 1 Disconnect and lockout the main power.**
- 2 Disconnect and lockout compressed air** (if equipped).
- 3 Shut off the cooling water in feed.**
- 4 Drain the unit of all fluid.** Remove the drain plug at the rear of the unit.
- 5 Remove the top and side panels of the RQT Standard.** *See section “Accessing the RQT Standard Enclosure.”*
- 6 Remove the pump assembly bolts.** Use a 9/16-inch open-end box wrench to remove the bolts holding the pump to the pump casing. The bolt in the rear will require a 9/16-inch socket wrench.
- 7 Lift the pump assembly straight up to remove.** The pump can now be replaced or disassembled for repair.
- 8 Reverse the steps to reassemble the unit.**

 **NOTE:** Before restarting, reprime the pump. Do not start until the pump is completely filled with water.

# Troubleshooting

---

Before Beginning .....	6-2
A Few Words of Caution .....	6-2
Identifying the Cause of a Problem .....	6-3
Controller Warnings and Alarms .....	6-4
RQT Standard Control Alarms .....	6-4
RQT Standard Control Alarm/Warnings.....	6-15
RQT Standard Control Warnings .....	6-24
Checking the RTD .....	6-26

Additional manuals and prints for your Thermal Care equipment may be ordered through the Customer Service or Parts Department for a nominal fee. Most manuals can be downloaded free of charge from the Resource Center of the Thermal Care website at [www.thermalcare.com](http://www.thermalcare.com)

## Before Beginning

You can avoid most problems by following the recommended installation, operation and maintenance procedures outlined in this User Guide. If you have a problem, this section will help you determine the cause and tell you how to fix it.

Before you begin troubleshooting:

- Find any wiring, parts, and assembly diagrams that were shipped with your equipment. These are the best reference for correcting a problem. The diagrams will note any custom features or options not covered in this User Guide.
- Verify that you have all instructional materials related to the RQT Standard. Additional details about troubleshooting and repairing specific components are found in these materials.
- Check that you have the manual for other equipment connected in the system. Troubleshooting may require investigating other equipment attached to, or connected with the RQT Standard.

## A Few Words of Caution



**WARNING: Improper installation, operation or servicing may result in equipment damage or personal injury.**

This equipment should only be installed, adjusted, and serviced by qualified technical personnel who are familiar with the construction, operation, and potential hazards of this type of machine.

All wiring, disconnects, and fuses should be installed and adjusted by qualified electrical technicians in accordance with electrical codes in your region. Always maintain a safe ground. Do not operate the equipment at power levels other than what is specified on the machine serial tag and data plate.



**WARNING: Electrical hazard**



Before performing maintenance or repairs on this product, disconnect and lock out electrical power sources to prevent injury from unexpected energization or start-up. Always follow lockout/tag out procedures to isolate this product from potentially hazardous electricity.



**WARNING: Compressed air hazard**

If you use compressed air, you must wear eye protection and observe all OSHA and other safety regulations pertaining to the use of compressed air. Bleed off pressure before servicing equipment.



**WARNING: Hot surface and liquid hazards**



Before attempting maintenance of any kind on the RQT Standard, you must stop the unit, disconnect and lockout the main power supply, and allow the unit to cool to less than 100° F {38° C}.



# Identifying the Cause of a Problem

The Troubleshooting section covers problems directly related to the operation and maintenance of the RQT Standard. This section does not provide solutions to problems that originate with other equipment. Additional troubleshooting help can be found in manuals supplied with the other equipment.

Unique alarm and warning messages on the temperature controller will alert you to many malfunctions.

**NOTE:** Additional troubleshooting help can be found in the documentation manuals included with this User Guide.



## When an Alarm condition occurs:

- 1 **Note error messages on the screen** to help determine the cause of the problem. This includes both the title and the scrolling description.
- 2 **Note what the machine was doing prior or during the alarm occurrence.** (Was it starting up, running steadily, etc.?)
- 3 **Find the alarm or warning in the diagnostics tables** in this section of the User Guide. Causes are listed in the order of most likely to least likely.
- 4 **Determine and fix the cause of the alarm.**
- 5 **Disconnect air and water supply lines as needed.**



**WARNING:** Always disconnect and lock out the main power source before opening the RQT Standard or its electrical enclosure.



# Controller Warnings and Alarms

The RQT Standard classifies machine faults as either warnings or alarms:

- **Alarms:** Problem is severe enough to shut down a running RQT Standard or prevent operation.
- **Warning:** RQT Standard can continue to run even though there is a minor malfunction detected in the machine.

Some malfunctions may have both alarms and warnings associated with it. The current operating mode of the RQT Standard determines whether the malfunction is classified as a warning or an alarm. For example, a tripped motor overload is a warning when the RQT Standard is sitting idle. This will become an alarm if the user attempts to start the RQT Standard and the motor tries to run.

Alarms and warnings are organized from highest to lowest priority. If multiple simultaneous malfunctions occur, the one with the highest priority will be shown.

## RQT Standard Control Alarms

The RQT Standard has detected a problem that could lead to equipment damage or personal injury if it is not corrected.

- ◆ The controller displays a solid alarm LED or an error message indicating the cause of the problem.

Alarm	Possible Cause	Solution
<p>Overtemp Fault</p> <p><b>Hardware Over-Temperature Trip</b></p> <p>The overtemperature intelock circuit has been broken.</p> <p><b>WARNING:</b> Only qualified electrical service personnel should examine and correct problems that require opening the unit's electrical enclosure or checking electrical current.</p> <ul style="list-style-type: none"><li>◆ Fault LED illuminated.</li><li>◆ Pump locks on.</li><li>◆ Heater locks off.</li><li>◆ Cooling valve locks open.</li></ul> <p><b>You should immediately disconnect power from the machine and investigate the source of the problem!</b> This alarm cannot be reset without a power cycle.</p>	<p>The overtemperature interlock jumper has been removed from the terminal strip.</p>	<ul style="list-style-type: none"><li><input type="checkbox"/> Verify that the overtemperature interlock jumper is still intact. See schematic prints for more details.</li><li><input type="checkbox"/> If the overtemperature interlock circuit has been re-routed to external equipment, investigate the external equipment for a malfunction.</li><li><input type="checkbox"/> Continuity through overtemperature interlock jumper must be present for the RQT Standard to function correctly.</li></ul>

(Continued)

# RQT Standard Control Alarms (Continued)

The RQT Standard has detected a problem that could lead to equipment damage or personal injury if it is not corrected.

- ◆ The controller displays a solid alarm LED or an error message indicating the cause of the problem.

Alarm	Possible Cause	Solution
<p>Htr Cntctr Stuck Closd</p> <p><b>Heater Contactor is Welded Closed</b></p> <p>The heater contactor is NOT disconnecting the heater when told to open by the temperature controller. The heater is likely running continuously.</p> <p><b>WARNING:</b> Only qualified electrical service personnel should examine and correct problems that require opening the unit's electrical enclosure or checking electrical current.</p> <ul style="list-style-type: none"> <li>◆ Fault LED illuminated.</li> <li>◆ Pump locks on.</li> <li>◆ Heater locks off (but probably still active due to malfunction).</li> <li>◆ Cooling valve locks open.</li> </ul> <p><b>You should immediately disconnect power from the machine and investigate the source of the problem!</b> This alarm cannot be reset without a power cycle.</p>	<p>Have the electromechanical heater contactor contacts welded shut and prevented the contactor from mechanically shutting to an open position?</p> <hr/> <p>Is a fault in the control wiring or temperature controller outputs continuously powering the heater contactor coil?</p>	<ul style="list-style-type: none"> <li><input type="checkbox"/> Replace the heater contactor.</li> <li><input type="checkbox"/> Ensure that the application is a cooling-based application and will only require heater operation for initial machine warm up. For applications requiring continuous heating regulation, contact Thermal Care Customer Service and inquire about Solid-State Relays which are much more appropriate for this application.</li> </ul> <hr/> <p>Test voltage between the A1 and A2 terminals (coil) on the heater contactor. If 24VDC is found, the contactor is probably NOT defective. Troubleshoot the problem by searching for the source of this voltage.</p>

(Continued)

## RQT Standard Control Alarms (Continued)

The RQT Standard has detected a problem that could lead to equipment damage or personal injury if it is not corrected.

- ◆ The controller displays a solid alarm LED or an error message indicating the cause of the problem.

Alarm	Possible Cause	Solution
<p>Temp Over Limit</p> <p><b>Factory Temperature – High Limit</b></p> <p>The process temperature has risen beyond the factory-configured maximum high limit.</p> <p><b>WARNING:</b> Only qualified electrical service personnel should examine and correct problems that require opening the unit's electrical enclosure or checking electrical current</p> <ul style="list-style-type: none"> <li>◆ Fault LED illuminated.</li> <li>◆ Pump locks on.</li> <li>◆ Heater locks off.</li> <li>◆ Cooling valve locks open.</li> </ul> <p><b>You should immediately disconnect power from the machine and investigate the source of the problem!</b> This alarm cannot be reset without a power cycle.</p>	<p>Has water stopped flowing between supply outlet and return inlet?</p>	<ul style="list-style-type: none"> <li><input type="checkbox"/> Verify that the unit is running and that the pump is working.</li> <li><input type="checkbox"/> Check for a plugged pipe or closed valve.</li> <li><input type="checkbox"/> Check for closed or defective cooling or vent valves and plugged lines. <i>See <a href="#">Repairing Cooling Valves</a>.</i></li> <li><input type="checkbox"/> Check for external closed valve on the process fluid going to external equipment.</li> </ul>
	<p>Did the cooling valve fail closed?</p>	<p>Check the cooling valve. <i>See <a href="#">Repairing Cooling Valves</a>, or the <a href="#">Solenoid Cooling Valve</a> instructions.</i></p>
	<p>Did a heater contactor fail with contacts welded closed?</p>	<p>Replace the contact if defective. <i>See <a href="#">Replacing the Heater Contactor</a>.</i></p>
	<p>Is the cooling valve under-sized for the application?</p>	<p>Check the cooling load (Btu/hr) for which the valve was specified.</p>
	<p>Is the cooling water return line plugged?</p>	<p>Verify the free flow of water out of the unit.</p>
	<p>Has the cooling water return pressure risen?</p>	<ul style="list-style-type: none"> <li><input type="checkbox"/> Check water return pressure with valve.</li> <li><input type="checkbox"/> Check for closed valve.</li> <li><input type="checkbox"/> Check for high pressure on gauge.</li> </ul>
	<p>Has the cooling water supply pressure dropped?</p>	<ul style="list-style-type: none"> <li><input type="checkbox"/> Check water supply pressure. If equipped, verify strainer not clogged.</li> <li><input type="checkbox"/> Check for closed valve on cooling water supply.</li> </ul>

(Continued)

## RQT Standard Control Alarms (Continued)

The RQT Standard has detected a problem that could lead to equipment damage or personal injury if it is not corrected.

- ◆ The controller displays a solid alarm LED or an error message indicating the cause of the problem.

Alarm	Possible Cause	Solution
<p>Pmp Cntctr Stuck Closd</p> <p><b>Pump Contactor is Welded Closed</b></p> <p>The pump contactor is NOT disconnecting the pump motor when told to open by the temperature controller. The pump is likely running continuously.</p> <p><b>WARNING:</b> Only qualified electrical service personnel should examine and correct problems that require opening the unit's electrical enclosure or checking electrical current.</p> <ul style="list-style-type: none"> <li>◆ Fault LED illuminated.</li> <li>◆ Pump turns off (although is probably still running due to malfunction).</li> <li>◆ Heater turns off.</li> <li>◆ Cooling valve closes</li> </ul> <p><b>Disconnect power to the RQT Standard in order to turn off the pump!</b></p>	<p>Have the electromechanical pump contactor contacts welded shut and are preventing the contactor from mechanically shutting to an open position?</p> <hr/> <p>Is a fault in the control wiring or temperature controller outputs continuously powering the pump contactor coil?</p>	<p>Replace the pump contactor.</p> <p>Contact Thermal Care Parts Phone: 847-966-8560</p> <hr/> <p>Test voltage between the A1 and A2 terminals (coil) on the pump contactor. If 24VDC is found, the contactor is probably NOT defective. Troubleshoot the problem by searching for the source of this voltage.</p>

(Continued)

## RQT Standard Control Alarms (Continued)

The RQT Standard has detected a problem that could lead to equipment damage or personal injury if it is not corrected.

- ◆ The controller displays a solid alarm LED or an error message indicating the cause of the problem.

Alarm	Possible Cause	Solution
<p>Htr Contctr Stuck Open</p> <p><b>Heater Contactor is NOT Closing</b></p> <p>The heater contactor is NOT energizing when told to close by the temperature controller. The heater is likely not able to energize.</p> <p><b>WARNING:</b> Only qualified electrical service personnel should examine and correct problems that require opening the unit's electrical enclosure or checking electrical current.</p> <ul style="list-style-type: none"> <li>◆ Fault LED illuminated.</li> <li>◆ Pump turns off.</li> <li>◆ Heater turns off (but probably was never on due to the fault).</li> <li>◆ Cooling valve closes.</li> </ul> <p><b>This alarm can be cleared by pushing the RESET  button.</b></p>	<p>Has the electromechanical heater contactor become jammed and is being prevented from mechanically shuttling to a closed position?</p> <hr/> <p>Is a fault in the control wiring or temperature controller outputs failing to provide power to the heater contactor coil?</p>	<ul style="list-style-type: none"> <li><input type="checkbox"/> Replace the heater contactor.</li> <li><input type="checkbox"/> Ensure that the application is a cooling-based application and will only require heater operation for initial machine warm up. For applications requiring continuous heating regulation, contact customer service and inquire about Solid-State Relays which are much more appropriate for this application.</li> </ul> <hr/> <p>Test voltage between the A1 and A2 terminals (coil) on the heater contactor. If 24VDC is never found, the contactor is probably NOT defective. Troubleshoot the problem by searching for why the control signal is not reaching the heater contactor coil.</p> <p style="text-align: right;">(Continued)</p>

## RQT Standard Control Alarms (Continued)

The RQT Standard has detected a problem that could lead to equipment damage or personal injury if it is not corrected.

- ◆ The controller displays a solid alarm LED or an error message indicating the cause of the problem.

Alarm	Possible Cause	Solution
<p>Pmp Contctr Stuck Open</p> <p><b>Pump Contactor is NOT Closing</b></p> <p>The pump contactor is NOT energizing when told to close by the temperature controller. The pump is likely not able to run.</p> <p><b>WARNING:</b> Only qualified electrical service personnel should examine and correct problems that require opening the unit's electrical enclosure or checking electrical current.</p> <ul style="list-style-type: none"> <li>◆ Fault LED illuminated.</li> <li>◆ Pump turns off (but probably never turned on due to the fault).</li> <li>◆ Heater turns off.</li> <li>◆ Cooling valve closes.</li> </ul> <p><b>This alarm can be cleared by pushing the RESET  button once the temperature returns to an acceptable level.</b></p>	<p>Has the electromechanical pump motor contactor become jammed and is being prevented from mechanically shuttling to a closed position?</p> <hr/> <p>Is a fault in the control wiring or temperature controller outputs failing to provide power to the heater contactor coil?</p>	<p>Replace the pump contactor.</p> <hr/> <p>Test voltage between the A1 and A2 terminals (coil) on the heater contactor. If 24VDC is never found, the contactor is probably NOT defective. Troubleshoot the problem by searching for why the control signal is not reaching the heater contactor coil.</p>

(Continued)

## RQT Standard Control Alarms (Continued)

The RQT Standard has detected a problem that could lead to equipment damage or personal injury if it is not corrected.

- ◆ The controller displays a solid alarm LED or an error message indicating the cause of the problem.

Alarm	Possible Cause	Solution
<p>Temp Under Limit</p> <p><b>Factory Temperature – Low Limit</b></p> <p>The process temperature has dropped below the factory-configured minimum low limit.</p> <p><b>WARNING:</b> Only qualified electrical service personnel should examine and correct problems that require opening the unit's electrical enclosure or checking electrical current.</p> <ul style="list-style-type: none"> <li>◆ Fault LED illuminated.</li> <li>◆ Pump turns off.</li> <li>◆ Heater turns off.</li> <li>◆ Cooling valve closes.</li> </ul> <p><b>This alarm can be cleared by pushing the RESET  button once the temperature returns to an acceptable level.</b></p>	<p>Is the cooling valve stuck open or leaking water?</p>	<p>Disassemble the cooling valve and check for particles blocking the valve seat. Check the valve seat for excessive wear. Replace as required using a valve repair kit. <i>See <a href="#">Repairing Cooling Valves</a>.</i></p>
	<p>Did a heater element fail or open?</p>	<p>With the unit powered down: Check for loose connections on heater wiring. Check resistance between the phase legs on the output (bottom) side of the heater contactor. Readings should be within 0.25 ohms of each other. Replace the heater, if necessary. <i>See <a href="#">Replacing Heater Elements</a>.</i></p>
	<p>Did the heater contactor fail open?</p>	<p>Replace the contactor if defective. <i>See <a href="#">Replacing the Heater Contactor</a>.</i></p>
	<p>Is the RTD malfunctioning?</p>	<p>Check the RTD loopin wiring with a VOM. <i>See <a href="#">Checking the RTD</a>.</i></p>
	<p>Is the RQT Standard under-sized for the application?</p>	<p>Review specifications and selection guidelines that apply to heater and pump sizes in temperature control units.</p>
	<p>Is the RQT Standard or equipment to which it is attached leaking?</p>	<p>Verify that there are no water leaks. Fix as necessary.</p>

(Continued)



# RQT Standard Control Alarms (Continued)

The RQT Standard has detected a problem that could lead to equipment damage or personal injury if it is not corrected.

- ◆ The controller displays a solid alarm LED or an error message indicating the cause of the problem.

Alarm	Possible Cause	Solution
<p>Temp Over Setting</p> <p><b>User Temperature – High Limit</b></p> <p>The process temperature has risen above the user-configured maximum high limit.</p> <p><b>WARNING:</b> Only qualified electrical service personnel should examine and correct problems that require opening the unit's electrical enclosure or checking electrical current.</p> <ul style="list-style-type: none"> <li>◆ Fault LED illuminated.</li> <li>◆ Pump turns off.</li> <li>◆ Heater turns off.</li> <li>◆ Cooling valve closes.</li> </ul> <p><b>This alarm can be cleared by pushing the RESET  button once the temperature returns to an acceptable level.</b></p>	<p>Has water stopped flowing through the unit or between the supply outlet and return inlet?</p>	<ul style="list-style-type: none"> <li><input type="checkbox"/> Verify that the unit is running and that the pump is working.</li> <li><input type="checkbox"/> Check for closed or defective cooling or vent valves and plugged lines. <i>See <a href="#">Repairing Cooling Valves</a>.</i></li> <li><input type="checkbox"/> Check for external closed valve on the process fluid going to external equipment.</li> <li><input type="checkbox"/> Check for a plugged pipe.</li> </ul>
	<p>Did the cooling valve fail closed?</p>	<p>Check the cooling valve. <i>See <a href="#">Repairing Cooling Valves</a> instructions.</i></p>
	<p>Is the temperature difference between the cooling water supply and the setpoint too small?</p>	<p>The temperature difference should be at least 25°F {14°C} to achieve proper cooling. Increase the process setpoint, decrease the cooling water supply temperature, or increase the cooling water supply pressure.</p>
	<p>Has the heater contactor failed with the contacts welded closed?</p>	<p>Replace the contactor if defective. <i>See <a href="#">Replacing the Heater Contactor</a>.</i></p>
	<p>Is the cooling valve under-sized for the application?</p>	<p>Check the cooling load (Btu/hr) for which the valve was specified.</p>
	<p>Is the high process temperature alarm too sensitive?</p>	<p>Increase the alarm trigger point. The recommended setting is the setpoint plus 2°F {4°C} to 10°F {18°C}.</p>
	<p>Is the cooling water return line plugged?</p>	<p>Verify the free flow of water out of the unit.</p>
	<p>Has the cooling water return pressure risen?</p>	<ul style="list-style-type: none"> <li><input type="checkbox"/> Check the water return pressure with pressure gauge.</li> <li><input type="checkbox"/> Check for a closed valve.</li> </ul>
	<p>Has the cooling water supply pressure dropped?</p>	<ul style="list-style-type: none"> <li><input type="checkbox"/> Check the water supply pressure. If equipped, verify that strainer is not clogged.</li> <li><input type="checkbox"/> Check for closed valve on cooling water.</li> </ul>

(Continued)

## RQT Standard Control Alarms (Continued)

The RQT Standard has detected a problem that could lead to equipment damage or personal injury if it is not corrected.

- ◆ The controller displays a solid alarm LED or an error message indicating the cause of the problem.

Alarm	Possible Cause	Solution
<p>Temp Under Setting</p> <p><b>User Temperature – Low Limit</b></p> <p>The process temperature has dropped below the user-configured minimum low limit.</p> <p><b>WARNING:</b> Only qualified electrical service personnel should examine and correct problems that require opening the unit’s electrical enclosure or checking electrical current.</p> <ul style="list-style-type: none"> <li>◆ Fault LED illuminated.</li> <li>◆ Pump turns off.</li> <li>◆ Heater turns off.</li> <li>◆ Cooling valve closes.</li> </ul> <p><b>This alarm can be cleared by pushing the RESET  button once the temperature returns to an acceptable level.</b></p>	<p>Is the cooling valve stuck open or leaking water?</p>	<p>Disassemble the cooling valve and check for particles blocking the valve seat. Check the valve seat for excessive wear. Replace as required using a valve repair kit. <i>See <a href="#">Repairing Cooling Valves</a>.</i></p>
	<p>Did a heater element fail or open?</p>	<p>With the unit powered down: Check for loose connections on heater wiring. Check resistance between the phase legs on the output side of the heater contactor (or SSR if present). Readings should be within 0.25 ohms of each other. Replace the heater, if necessary. <i>See <a href="#">Replacing Heater Elements</a>.</i></p>
	<p>Did the heater contactor fail open?</p>	<p>Replace the contactor if defective. <i>See <a href="#">Replacing the Heater Contactor</a>.</i></p>
	<p>Is the low process temperature alarm too sensitive?</p>	<p>Increase the alarm trigger point. The recommended setting is the setpoint minus 2°F {4°C} to 10°F {18°C}.</p>
	<p>Is the RQT Standard under-sized for the application?</p>	<p>Review specifications and selection guidelines that apply to heater and pump sizes in temperature control units.</p>
	<p>Is the RQT Standard or equipment to which it is attached leaking?</p>	<p>Verify that there are no water leaks. Fix as necessary.</p>

(Continued)

## RQT Standard Control Alarms (Continued)

The RQT Standard has detected a problem that could lead to equipment damage or personal injury if it is not corrected.

- ◆ The controller displays a solid alarm LED or an error message indicating the cause of the problem.

Alarm	Possible Cause	Solution
<p>Low Pressure Shutdown</p> <p><b>Process Coolant Low Pressure Timeout</b></p> <p>The RQT Standard has remained temporarily shut down with a low pressure warning for an excessive amount of time.</p> <p><b>WARNING:</b> Only qualified electrical service personnel should examine and correct problems that require opening the unit's electrical enclosure or checking electrical current.</p> <ul style="list-style-type: none"> <li>◆ Fault LED illuminated.</li> <li>◆ Pump turns off.</li> <li>◆ Heater turns off.</li> <li>◆ Cooling valve closes.</li> </ul> <p><b>This alarm can be cleared by pushing the RESET  button once the temperature returns to an acceptable level.</b></p>	<p>Water pressure in your building or process loop is only marginally acceptable to run the RQT Standard. Any small fluctuations can cause the RQT Standard to cycle off.</p>	<p>Observe the building/process loop water pressure over time. If it drops below the minimum require pressure, you will need to upgrade your facility plumbing, or add an external booster pump.</p> <p>Be sure your measurements are taken when the TCU is consuming cooling water since that will lower the pressure further.</p>
	<p>Other equipment fed from the same water line as the RQT Standard is consuming significant water flow. Due to the high demand, pressure at the RQT Standard drops.</p>	<p>If permitted by the manufacturer of the other equipment, install flow reducers to the other equipment so that flow is restricted to a reasonable level and sufficient pressure is retained for the RQT Standard.</p>
	<p>Is there a leak in the process loop?</p>	<p>Fix the leak.</p>

(Continued)

## RQT Standard Control Alarms (Continued)

The RQT Standard has detected a problem that could lead to equipment damage or personal injury if it is not corrected.

- ◆ The controller displays a solid alarm LED or an error message indicating the cause of the problem.

Alarm	Possible Cause	Solution
<p>Low Pressure Events</p> <p><b>Coolant Low Pressure Low Events</b></p> <p>The RQT Standard has experienced too many low pressure warnings within a certain time period.</p> <p><b>WARNING:</b> Only qualified electrical service personnel should examine and correct problems that require opening the unit's electrical enclosure or checking electrical current.</p> <ul style="list-style-type: none"> <li>◆ Fault LED illuminated.</li> <li>◆ Pump turns off.</li> <li>◆ Heater turns off.</li> <li>◆ Cooling valve closes.</li> </ul> <p><b>This alarm can be cleared by pushing the RESET  button once the temperature returns to an acceptable level.</b></p>	<p>Water pressure in your building or process loop is only marginally acceptable to run the RQT Standard. Any small fluctuations can cause the RQT Standard to cycle on and off repeatedly.</p> <hr/> <p>Other equipment fed from the same water line as the RQT Standard is consuming significant water flow at intermittent intervals. Due to the high demand, pressure at the RQT Standard temporarily drops.</p>	<p>Observe the building/process loop water pressure over time. If it drops below the minimum require pressure, you will need to upgrade your facility plumbing, or add an external booster pump.</p> <p>Be sure your measurements are taken when the TCU is consuming cooling water since that will lower the pressure further.</p> <hr/> <p>If permitted by the manufacturer of the other equipment, install flow reducers to the other equipment so that flow is restricted to a reasonable level and sufficient pressure is retained for the RQT Standard.</p>

The triggering of this alarm is governed by user parameters, “Low Pres Count” and “Low Pres Time”. *See user parameter details for adjustment of these parameters if necessary.*



**NOTE:** changing these parameters to allow the pump to frequently start/stop with fluctuating water pressure will decrease the life of the pump and the pump contactor.

# RQT Standard Control Alarm/Warnings

The RQT Standard has detected a problem that could potentially lead to equipment damage or personal injury if it is not corrected.

- ◆ The controller displays a flashing/solid alarm LED or an error message indicating the cause of the problem.

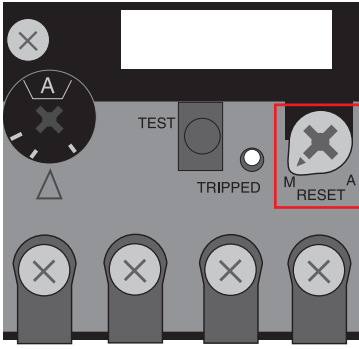
Alarm or Warning	Possible Cause	Solution
<p>Pump Overload Tripped</p>	<p>Is enough restriction provided in the fluid circuit loop?</p>	<p>Install a flow-reducing orifice or introduce some additional fittings/smaller diameter piping.</p>
<p><b>Pump Overload</b></p>		
<p>The pump is pulling more electrical current than its maximum ratings permit. This is probably due to excessive mechanical loading (high pump fluid flow) of the motor.</p>	<p>Is there mechanical binding due to a physical jam/obstruction in the pump casing volute?</p>	<p>Remove the endcap from the motor and check that the shaft is free to rotate. If not, <i>see Removing the Pump and Motor.</i></p>
<p><b>WARNING:</b> Only qualified electrical service personnel should examine and correct problems that require opening the unit's electrical enclosure or checking electrical current.</p>	<p>Have the bearings in the motor failed, causing excessive mechanical loading or misalignment?</p>	<p>Remove the endcap from the motor and check that the shaft is free to rotate. If not, <i>see Removing the Pump and Motor.</i></p>
<p><b>If Warning:</b></p>	<p>Is the correct voltage supplied to the pump motor?</p>	<p>Supply voltage should match the rating on the pump nameplate ±10%. If voltage is correct, check wiring connections.</p>
<ul style="list-style-type: none"> <li>◆ Fault LED flashes.</li> <li>◆ RQT Standard must not be currently running. If run, it will alarm as soon as pump is started.</li> </ul>	<p>Is a phase open?</p>	<p>Check voltage, L1 to L2, L2 to L3, L3 to L1. All should be within 3% voltage imbalance*.</p>
<p><b>If Alarm:</b></p>	<p>Is the motor overload faulty or set incorrectly?</p>	<p>Disconnect the power and open the electrical enclosure. Verify that the overload is set to trip at the proper amperage, which is specified on the electrical power prints. Manually trip (by pulling the red trip handle) and reset the overload (by pushing the blue RESET button). If the problem continues, replace the overload. <i>See Resetting and Replacing Overloads.</i></p>
<ul style="list-style-type: none"> <li>◆ Fault LED illuminated.</li> <li>◆ RQT Standard will not run.</li> <li>◆ <b>The RESET button on the OVERLOAD must be depressed to clear this fault. <i>See Resetting Pump Overload section.</i></b></li> </ul>		
<p>* % Voltage imbalance = 100 x (Maximum deviation from average voltage) / (average voltage)</p>		

(Continued)

## RQT Standard Control Alarm/Warnings (Continued)

The RQT Standard has detected a problem that could potentially lead to equipment damage or personal injury if it is not corrected.

- ◆ The controller displays a flashing/solid alarm LED or an error message indicating the cause of the problem.

Alarm or Warning	Possible Cause	Solution
<p>To-Process Probe Open</p> <p><b>To-Process (Supply) RTD Temperature Probe Open Circuit</b></p> <p>The "To-Process" RTD is malfunctioning or has a break in the wiring.</p> <p><b>WARNING:</b> Only qualified electrical service personnel should examine and correct problems that require opening the unit's electrical enclosure or checking electrical current.</p> <p><b>If Warning (To-Process probe not controlling):</b></p> <ul style="list-style-type: none"> <li>◆ Fault LED flashes.</li> <li>◆ RQT Standard will run normally.</li> </ul> <p><b>If Alarm (To-Process probe is controlling):</b></p> <ul style="list-style-type: none"> <li>◆ Fault LED illuminated.</li> <li>◆ RQT Standard will not run.</li> </ul> <p><b>This fault will automatically reset when the problem is corrected.</b></p>	<p>Do you have a break in your RTD wiring?</p>	<p>Check the RTD loop wiring with a VOM. <i>See Checking the RTD.</i></p>
	<p>Do you have a loose wire?</p>	<p>Test the RTD with a VOM. <i>See Checking the RTD.</i></p>
	<p>Has the RTD itself failed or sustained physical damage?</p>	<p>If damaged, replace the RTD.</p> <p>Parts and Service Phone: 847-966-8560</p>
	<p>As a temporary solution (with reduced performance), you may choose to make the From-Process probe controlling. See user parameter "PV Source". This will demote the alarm to a warning and allow you to continue to run.</p>	

(Continued)

## RQT Standard Control Alarm/Warnings (Continued)

The RQT Standard has detected a problem that could potentially lead to equipment damage or personal injury if it is not corrected.

- ◆ The controller displays a flashing/solid alarm LED or an error message indicating the cause of the problem.

Alarm or Warning	Possible Cause	Solution
To-Process Probe Short	Do you have a short-circuit in your RTD wiring?	Check the RTD loop wiring with a VOM. <i>See Checking the RTD.</i>
<b>To-Process (Supply) RTD Temperature Probe Short Circuit</b>	Do you have a wire whisker that is bridging across two adjacent terminals?	Test the RTD with a VOM. <i>See Checking the RTD.</i>
The "To-Process" RTD is malfunctioning or has a short in the wiring.		
<b>WARNING:</b> Only qualified electrical service personnel should examine and correct problems that require opening the unit's electrical enclosure or checking electrical current.	Has the RTD itself failed or sustained physical damage?	If damaged, replace the RTD.
<b>If Warning (To-Process probe not controlling):</b>	As a temporary solution (with reduced performance), you may choose to make the From-Process probe controlling. See user parameter "PV Source". This will demote the alarm to a warning and allow you to continue to run.	
<ul style="list-style-type: none"> <li>◆ Fault LED flashes.</li> <li>◆ RQT Standard will run normally.</li> </ul>		
<b>If Alarm (To-Process probe is controlling):</b>		
<ul style="list-style-type: none"> <li>◆ Fault LED illuminated.</li> <li>◆ RQT Standard will not run.</li> </ul>		
<b>This fault will automatically reset when the problem is corrected.</b>		

(Continued)

## RQT Standard Control Alarm/Warnings (Continued)

The RQT Standard has detected a problem that could potentially lead to equipment damage or personal injury if it is not corrected.

- ◆ The controller displays a flashing/solid alarm LED or an error message indicating the cause of the problem.

Alarm or Warning	Possible Cause	Solution
<p>To-Process Probe Error</p> <p><b>To-Process (Supply) RTD Temperature Probe Channel Error</b></p> <p>The "To-Process" RTD is picking up external voltages or there is a malfunction in the temperature controller.</p> <p><b>WARNING:</b> Only qualified electrical service personnel should examine and correct problems that require opening the unit's electrical enclosure or checking electrical current.</p> <p><b>If Warning (To-Process probe not controlling):</b></p> <ul style="list-style-type: none"> <li>◆ Fault LED flashes.</li> <li>◆ RQT Standard will run normally.</li> </ul> <p><b>If Alarm (To-Process probe is controlling):</b></p> <ul style="list-style-type: none"> <li>◆ Fault LED illuminated.</li> <li>◆ RQT Standard will not run.</li> </ul> <p><b>This fault will automatically reset when the problem is corrected.</b></p>	<p>Has the RTD wiring become exposed to an external voltage source?</p> <hr/> <p>Has the temperature controller sustained hardware damage on the RTD input channel?</p>	<ul style="list-style-type: none"> <li><input type="checkbox"/> Inspect the RTD loop wiring with a VOM. <i>See <a href="#">Checking the RTD</a>.</i></li> <li><input type="checkbox"/> Test the RTD with a VOM. <i>See <a href="#">Checking the RTD</a>.</i></li> <li><input type="checkbox"/> Disconnect the RTD wiring from the temperature controller and observe if the fault disappears. (It should be replaced by a To-Process, Probe Open Error.)</li> </ul> <hr/> <p>If damaged, replace the temperature controller.</p>
	<p>As a temporary solution (with reduced performance), you may choose to make the From-Process probe controlling. See user parameter "PV Source". This will demote the alarm to a warning and allow you to continue to run.</p>	

(Continued)



## RQT Standard Control Alarm/Warnings (Continued)

The RQT Standard has detected a problem that could potentially lead to equipment damage or personal injury if it is not corrected.

- ◆ The controller displays a flashing/solid alarm LED or an error message indicating the cause of the problem.

Alarm or Warning	Possible Cause	Solution
From-Proc Probe Open	Do you have a break in your RTD wiring?	Check the RTD loop wiring with a VOM. <i>See Checking the RTD.</i>
<b>From-Process (Return) RTD Temperature Probe Open Circuit</b>	Do you have a loose wire?	Test the RTD with a VOM. <i>See Checking the RTD.</i>
<p>The "From-Process" RTD is malfunctioning or has a break in the wiring.</p> <p><b>WARNING:</b> Only qualified electrical service personnel should examine and correct problems that require opening the unit's electrical enclosure or checking electrical current.</p>	Has the RTD itself failed or sustained physical damage?	<p>If damaged, replace the RTD.</p> <p>Contact Thermal Care Parts Phone: 847-966-8560</p>
<p><b>If Warning (From-Process probe not controlling):</b></p> <ul style="list-style-type: none"> <li>◆ Fault LED flashes.</li> <li>◆ RQT Standard will run normally.</li> </ul>	As a temporary solution (with reduced performance), you may choose to make the To-Process probe controlling. See user parameter "PV Source". This will demote the alarm to a warning and allow you to continue to run.	
<p><b>If Alarm (From-Process probe is controlling):</b></p> <ul style="list-style-type: none"> <li>◆ Fault LED illuminated.</li> <li>◆ RQT Standard will not run.</li> </ul> <p><b>This fault will automatically reset when the problem is corrected.</b></p>		

(Continued)

## RQT Standard Control Alarm/Warnings (Continued)

The RQT Standard has detected a problem that could potentially lead to equipment damage or personal injury if it is not corrected.

- ◆ The controller displays a flashing/solid alarm LED or an error message indicating the cause of the problem.

Alarm or Warning	Possible Cause	Solution
<p>From-Proc Probe Short</p>	<p>Do you have a short-circuit in your RTD wiring?</p>	<p>Check the RTD loop wiring with a VOM. <i>See Checking the RTD.</i></p>
<p><b>From-Process (Return) RTD Temperature Probe Short Circuit</b></p>	<p>Do you have a wire whisker that is bridging across two adjacent terminals?</p>	<p>Test the RTD with a VOM. <i>See Checking the RTD.</i></p>
<p>The "From-Process" RTD is malfunctioning or has a short in the wiring.</p>		
<p><b>WARNING:</b> Only qualified electrical service personnel should examine and correct problems that require opening the unit's electrical enclosure or checking electrical current.</p>	<p>Has the RTD itself failed or sustained physical damage?</p>	<p>If damaged, replace the RTD.  Contact Thermal Care Parts and Service</p>
<p><b>If Warning (From-Process probe not controlling):</b></p>		
<ul style="list-style-type: none"> <li>◆ Fault LED flashes.</li> <li>◆ RQT Standard will run normally.</li> </ul>	<p>As a temporary solution (with reduced performance), you may choose to make the To-Process probe controlling. See user parameter "PV Source". This will demote the alarm to a warning and allow you to continue to run.</p>	
<p><b>If Alarm (From-Process probe is controlling):</b></p>		
<ul style="list-style-type: none"> <li>◆ Fault LED illuminated</li> <li>◆ RQT Standard will not run.</li> </ul>		
<p><b>This fault will automatically reset when the problem is corrected.</b></p>		

(Continued)

# RQT Standard Control Alarm/Warnings (Continued)

The RQT Standard has detected a problem that could potentially lead to equipment damage or personal injury if it is not corrected.

- ◆ The controller displays a flashing/solid alarm LED or an error message indicating the cause of the problem.

Alarm or Warning	Possible Cause	Solution
<p>From-Proc Probe Error</p> <p><b>From-Process (Return) RTD Temperature Probe Channel Error</b></p> <p>The "From-Process" RTD is picking up external voltages or there is a malfunction in the temperature controller.</p> <p><b>WARNING:</b> Only qualified electrical service personnel should examine and correct problems that require opening the unit's electrical enclosure or checking electrical current.</p> <p><b>If Warning (From-Process probe not controlling):</b></p> <ul style="list-style-type: none"> <li>◆ Fault LED flashes.</li> <li>◆ RQT Standard will run normally.</li> </ul>	<p>Has the RTD wiring become exposed to an external voltage source?</p>	<ul style="list-style-type: none"> <li><input type="checkbox"/> Inspect the RTD loop wiring with a VOM. <i>See Checking the RTD.</i></li> <li><input type="checkbox"/> Test the RTD with a VOM. <i>See Checking the RTD.</i></li> <li><input type="checkbox"/> Disconnect the RTD wiring from the temperature controller and observe if the fault disappears. (It should be replaced by a From-Proc Probe Open Error.)</li> </ul>
<p><b>If Alarm (From-Process probe is controlling):</b></p> <ul style="list-style-type: none"> <li>◆ Fault LED illuminated</li> <li>◆ RQT Standard will not run.</li> </ul> <p><b>This fault will automatically reset when the problem is corrected.</b></p>	<p>Has the temperature controller sustained hardware damage on the RTD input channel?</p>	<p>If damaged, replace the temperature controller.</p> <p>Contact Thermal Care Parts and Service</p>
<p>As a temporary solution (with reduced performance), you may choose to make the To-Process probe controlling. See user parameter "PV Source". This will demote the alarm to a warning and allow you to continue to run.</p>		

(Continued)

## RQT Standard Control Alarm/Warnings (Continued)

The RQT Standard has detected a problem that could potentially lead to equipment damage or personal injury if it is not corrected.

- ◆ The controller displays a flashing/solid alarm LED or an error message indicating the cause of the problem.



Alarm or Warning	Possible Cause	Solution
<p>High Temp Deviation</p> <p><b>Deviation Alarm – Over Setpoint</b></p> <p>The process temperature has exceeded the allowable high deviation window for a certain amount of time.</p> <p><b>WARNING:</b> Only qualified electrical service personnel should examine and correct problems that require opening the unit's electrical enclosure or checking electrical current.</p> <p><b>If Warning:</b></p> <ul style="list-style-type: none"> <li>◆ Fault LED flashes.</li> <li>◆ RQT Standard will run normally.</li> </ul> <p><b>If Alarm:</b></p> <ul style="list-style-type: none"> <li>◆ Fault LED illuminated</li> <li>◆ RQT Standard will shut down until the alarm is reset and then can be immediately restarted.</li> </ul> <p><b>If a warning, it will automatically reset when the problem is corrected.</b></p> <p><b>If an alarm, push the RESET button to clear this alarm</b> </p>	<p>Has water stopped flowing throughout the unit or between supply outlet and return inlet?</p> <p>Did the cooling valve fail closed?</p> <p>Is the temperature difference between the cooling water supply and the setpoint too small?</p> <p>Is the cooling valve under-sized for the application?</p> <p>Is the high process temperature alarm too sensitive?</p> <p>Is the high deviation temperature alarm delay too short?</p> <p>Is the initial deviation alarm delay parameter too short?</p> <p>Are the PID parameters set correctly?</p>	<p>Verify that the unit is running and that the pump is working.</p> <p>Check for closed or defective cooling or vent valves and plugged lines. <i>See <a href="#">Repairing Cooling Valves</a>.</i></p> <p>Check for external closed valve on the process fluid going to external equipment.</p> <p>Check for a plugged pipe.</p> <p>Check the cooling valves. <i>See <a href="#">Repairing Cooling Valves instructions</a>.</i></p> <p>The temperature difference should be at least 25°F {14°C} to achieve proper cooling. Increase the process setpoint, decrease the cooling water supply temperature or increase the cooling water supply pressure.</p> <p>Check the cooling load (Btu/ hr) for which the valve was specified.</p> <p>Modify the high deviation alarm trigger point by increasing parameter "High Deviation".</p> <p>Modify the high deviation alarm delay by increasing parameter "High Devtn Dly".</p> <p>Modify the warm-up ignore deviation delay by increasing parameter "Warm Up Delay".</p> <p>Check the PID parameters, including: "P-Band", "I-Gain", "D-Gain", and "Deadband".</p>
<p> <b>NOTE:</b> A high temperature deviation condition can trigger an alarm, warning, or do nothing according to the desired action set by the user parameter "Deviation Actn".</p>		

(Continued)

# RQT Standard Control Alarm/Warnings (Continued)

The RQT Standard has detected a problem that could potentially lead to equipment damage or personal injury if it is not corrected.

- ◆ The controller displays a flashing/solid alarm LED or an error message indicating the cause of the problem.

Alarm or Warning	Possible Cause	Solution
<p>Low Temp Deviation</p> <p><b>Deviation Alarm – Under Setpoint</b></p> <p>The process temperature has dropped below the allowable low deviation window for a certain amount of time.</p>	<p>Is the cooling valve stuck open or leaking water?</p>	<p>Disassemble the cooling valve and check for particles blocking the valve seat. Check the valve seat for excessive wear. Replace as required using a valve repair kit. <i>See <a href="#">Repairing Cooling Valves</a>.</i></p>
<p><b>WARNING:</b> Only qualified electrical service personnel should examine and correct problems that require opening the unit's electrical enclosure or checking electrical current.</p> <p><b>If Warning:</b></p> <ul style="list-style-type: none"> <li>◆ Fault LED flashes.</li> <li>◆ RQT Standard will run normally.</li> </ul>	<p>Did a heater element fail or open?</p>	<p>With the unit powered down: Check for loose connections on heater wiring. Check resistance between the phase legs on the output side of the heater contactor. Readings should be within 0.25 ohms of each other. Replace the heater, if necessary. <i>See <a href="#">Replacing Heater Elements</a>.</i></p>
<p><b>If Alarm:</b></p> <ul style="list-style-type: none"> <li>◆ Fault LED illuminated</li> <li>◆ RQT Standard will shut down until the alarm is reset and then can be immediately restarted.</li> </ul>	<p>Did a heater contactor fail open?</p>	<p>Replace the contactor if defective. <i>See <a href="#">Replacing the Heater Contactor</a>.</i></p>
<p><b>If a warning, it will automatically reset when the problem is corrected.</b></p> <p><b>If an alarm, push the RESET button to clear this alarm</b> </p>	<p>Is the low process temperature alarm too sensitive?</p>	<p>Modify the low deviation alarm trigger point by increasing parameter "Low Deviation".</p>
	<p>Is the low deviation temperature alarm delay too short?</p>	<p>Modify the low deviation alarm delay by increasing parameter "Low Devtn Dly".</p>
	<p>Is the RQT Standard under-sized for the application?</p>	<p>Review specifications and selection guidelines that apply to heater and pump sizes in temperature control units.</p>
	<p>Is the RQT Standard or equipment to which it is attached leaking?</p>	<p>Verify that there are no water leaks. Fix as necessary.</p>
	<p>Are the PID parameters set correctly?</p>	<p>Check the PID parameters, including: "P-Band", "I-Gain", "D-Gain", and "Deadband".</p>
	<p> <b>NOTE:</b> A temperature deviation condition can trigger an alarm, warning, or do nothing according to the desired action set by the user parameter "Deviation Actn".</p>	

# RQT Standard Control Warnings

The RQT Standard has detected a problem that could potentially lead to equipment damage or personal injury if it is not corrected.

- ◆ The controller displays a flashing alarm LED or an error code indicating the cause of the problem.

Warning	Possible Cause	Solution
<p>Low Process Inlet Pres</p> <p><b>Low Process Coolant Inlet Pressure</b></p> <p>The RQT Standard coolant circuit does not have enough pressure to operate the pump or heater.</p> <p><b>WARNING:</b> Only qualified electrical service personnel should examine and correct problems that require opening the unit's electrical enclosure or checking electrical current.</p> <ul style="list-style-type: none"> <li>◆ Fault LED illuminated.</li> <li>◆ Run LED flashes.</li> <li>◆ Pump temporarily turns off.</li> <li>◆ Heater temporarily turns off.</li> <li>◆ Cooling valve continues to regulate.</li> </ul> <p><b>This warning will automatically reset when system pressure returns.</b> When it does, the RQT Standard will automatically resume normal operation.</p>	<p>Is fresh water turned on to the RQT Standard?</p> <hr/> <p>Does your facility have the required water pressure to run the RQT Standard (25psi)?</p> <hr/> <p>Is the pressure switch faulty?</p> <hr/> <p>Is there a leak in the process loop?</p>	<p>Be sure to turn on the water supply before starting the RQT Standard. The pressure status is indicated on the screen by absence of this warning even when the RQT Standard is not running.</p> <hr/> <p><input type="checkbox"/> Observe the pressure indicated on the pressure gauges.</p> <p><input type="checkbox"/> Upgrade your facility plumbing if necessary, or add an external booster pump.</p> <hr/> <p>If you are sure that sufficient water pressure is present, test the pressure switch with a VOM. Low pressure should allow the switch to open, whereas high pressure should cause it to close.</p> <hr/> <p>Fix the leak.</p>
<p>Flash Memory Error</p> <p><b>Excessive Flash Memory Writes</b></p> <p>The flash memory is being written to excessively.</p> <ul style="list-style-type: none"> <li>◆ RQT Standard operation is not affected.</li> </ul> <p><b>This warning will automatically reset when the flash memory writes return to a normal rate.</b></p>	<p>Something abnormal may be occurring in the temperature controller.</p>	<p>Contact Thermal Care Customer Service 847-966-2636.</p>

(Continued)

## RQT Standard Control Warnings (Continued)

The RQT Standard has detected a problem that could potentially lead to equipment damage or personal injury if it is not corrected.

- ◆ The controller displays a flashing alarm LED or an error code indicating the cause of the problem.

Warning	Possible Cause	Solution
<b>Heater Contactor Worn Out</b>  <b>WARNING:</b> Only qualified electrical service personnel should examine and correct problems that require opening the unit's electrical enclosure or checking electrical current.  ◆ Fault LED flashes.	Normal wear and tear of the electro-mechanical contactor.	Contact Thermal Care Parts for replacement electro-mechanical contactor.  Phone: 847-966-8560
	PIO Loop Mistuned.	Contact Thermal Care Parts Phone 847-966-8560
<b>Heater Cyclic Rate Too High</b>  ◆ Fault LED flashes.	TCU Mis-applied.	If application requires continuous heating, this is not the correct TCU model. Please reach out to your Thermal Care representative.
	PIO Loop Mistuned.	Contact Thermal Care Customer Service Phone 847-966-2636
	TCU Mis-applied.	If application requires continuous heating, this is not the correct TCU model. Please reach out to your Thermal Care representative.

## Checking the RTD



### **WARNING: Electrical Shock Hazard**



Only qualified service personnel who have been trained on electrical testing and the procedures for avoiding the hazards should diagnose or correct problems that require opening the unit with power on.

The RQT Standard uses Pt1000 RTDs, to monitor the to process and from process temperatures. The Pt 1000 “To Process” RTD is installed in the wall of the heater tank at the “to process” outlet. The Pt 1000 “From Process” RTD is installed in the mixing tank.

### **To check a RTD after a sensor error:**

- 1 Disconnect and lockout the main power.**
- 2 Open the electrical enclosure door.** Turn the screw on the front panel counterclockwise to open.
- 3 Remove RTD wiring terminal strip.** Refer to the wiring diagrams that came with your unit.
- 4 Verify the resistance of the RTD using a VOM. Compare against table on next page. Polarity does not matter. If incorrect, replace.**



# Checking the RTD (Cont'd)

Pt1000

	0	1	2	3	4	5	6	7	8	9	
Temp T	Resistance at T	Resistance at T+1°F	Resistance at T+2°F	Resistance at T+3°F	Resistance at T+4°F	Resistance at T+5°F	Resistance at T+6°F	Resistance at T+7°F	Resistance at T+8°F	Resistance at T+9°F	Temp T
°F	Ohms	Ohms	Ohms	Ohms	Ohms	Ohms	Ohms	Ohms	Ohms	Ohms	°C
50	1039	1041	1043	1046	1048	1050	1052	1054	1056	1058	10.0
60	1061	1063	1065	1067	1069	1071	1074	1076	1078	1080	15.6
70	1082	1084	1087	1089	1091	1093	1095	1097	1099	1102	21.1
80	1104	1106	1108	1110	1112	1115	1117	1119	1121	1123	26.7
90	1125	1127	1130	1132	1134	1136	1138	1140	1143	1145	32.2
100	1147	1149	1151	1153	1155	1158	1160	1162	1164	1166	37.8
110	1168	1170	1173	1175	1177	1179	1181	1183	1185	1188	43.3
120	1190	1192	1194	1196	1198	1200	1203	1205	1207	1209	48.9
130	1211	1213	1215	1217	1220	1222	1224	1226	1228	1230	54.4
140	1232	1235	1237	1239	1241	1243	1245	1247	1249	1252	60.0
150	1254	1256	1258	1260	1262	1264	1266	1269	1271	1273	65.6
160	1275	1277	1279	1281	1283	1286	1288	1290	1292	1294	71.1
170	1296	1298	1300	1303	1305	1307	1309	1311	1313	1315	76.7
180	1317	1320	1322	1324	1326	1328	1330	1332	1334	1336	82.2
190	1339	1341	1343	1345	1347	1349	1351	1353	1355	1358	87.8
200	1360	1362	1364	1366	1368	1370	1372	1374	1377	1379	93.3
210	1381	1383	1385	1387	1389	1391	1393	1396	1398	1400	98.9
220	1402	1404	1406	1408	1410	1412	1414	1417	1419	1421	104.4
230	1423	1425	1427	1429	1431	1433	1435	1438	1440	1442	110.0
240	1444	1446	1448	1450	1452	1454	1456	1459	1461	1463	115.6
250	1465	1467	1469	1471	1473	1475	1477	1479	1482	1484	121.1
260	1486	1488	1490	1492	1494	1496	1498	1500	1502	1504	126.7
270	1507	1509	1511	1513	1515	1517	1519	1521	1523	1525	132.2
280	1527	1530	1532	1534	1536	1538	1540	1542	1544	1546	137.8
290	1548	1550	1552	1554	1557	1559	1561	1563	1565	1567	143.3
300	1569	1571	1573	1575	1577	1579	1581	1584	1586	1588	148.9

*This page intentionally left blank.*

# Appendix A

---

## We're Here to Help

Thermal Care has made a large investment in customer support. Our service experts are available to help with any problem you might have installing and operating your equipment. Your Thermal Care sales representative also can help analyze the nature of your problem, assuring that it did not result from misapplication or improper use.

## How to Contact Customer Service

To contact Customer Service, call 847-966-2636 or via email at [tsservice@thermalcare.com](mailto:tsservice@thermalcare.com):

To contact Parts, call 847-966-8560 or via email at [tcparts@thermalcare.com](mailto:tcparts@thermalcare.com)

 **NOTE:** Normal operating hours are 8:00 am - 5:00 pm CST. After hours emergency service is available at the same phone number.

## Before You Call...

**If you do have a problem, please complete the following checklist before calling Thermal Care:**

- Make sure you have all model, control type from the serial tag, and parts list numbers for your particular equipment. Service personnel will need this information to assist you.
- Make sure power is supplied to the equipment.
- Make sure that all connectors and wires within and between control systems and related components have been installed correctly.
- Check the troubleshooting guide of this manual for a solution.
- Thoroughly examine the instruction manual(s) for associated equipment, especially controls. Each manual may have its own troubleshooting guide to help you.
- Check that the equipment has been operated as described in this manual.
- Check accompanying schematic drawings for information on special considerations.



# Appendix B

## User Parameters

The RQT Standard will not operate correctly if certain factory-set parameters are changed. Parameters should be changed only by qualified technical personnel who are familiar with the operation of this type of equipment.

If the RQT Standard does not appear to be working correctly, verify the parameters against the list of factory settings.

For more detailed information about these parameters and returning parameters to the initial factory setup, *See RQT Standard initial setup, Section 3.*

Category	Screen Number	Parameter (Character Limited)	Default	Range	Description
Deviation Alarm Setup	1/6	Warm Up Delay	30 min	0-999 min	The TCU will not look for a deviation condition until setpoint has been achieved and the machine is running in steady state. This parameter is the maximum amount of time the TCU will wait for setpoint to be achieved and will therefore ignore a deviation condition. If you have a large tool that takes longer than this delay to reach steady-state conditions, increase this value to eliminate false tripping of the deviation alarm.
		High Deviation	10 Δ°F	1-216 Δ°F	How far the temperature must deviate above setpoint before registering a high deviation condition. This deviation condition is also subject to parameter "High Devtn Dly" below.
		Low Deviation	10 Δ°F	1-216 Δ°F	How far the temperature must deviate below setpoint before registering a low deviation condition. This deviation condition is also subject to parameter "Low Devtn Dly" below.
		High Devtn Dly	30 min	0-720 min	How long to wait before alerting the user via an alarm or warning once a high deviation condition exists. If the deviation condition disappears, the timer is reset. See parameter "Deviation Actn" below for selecting whether a deviation condition produces an alarm or a warning.
		Low Devtn Dly	30 min	0-720 min	How long to wait before alerting the user via an alarm or warning once a low deviation condition exists. If the deviation condition disappears, the timer is reset. See parameter "Deviation Actn" below for selecting whether a deviation condition produces an alarm or a warning.

(Continued)

## User Parameters (Continued)

Category	Screen Number	Parameter (Character Limited)	Default	Range	Description
Limit Alarm Setup	2/6	High Temp Alm	260 °F	32-260 °F	User configurable maximum temperature alarm.
		Low Temp Alm	32 °F	32-260 °F	User configurable minimum temperature alarm.
		Low Pres Recov	1500 ms	0-60000 ms	If the TCU has paused operation due to low process temperature, this is how long it will wait before automatically restarting after the return of pressure. If your facility suffers from water hammer effects, increase this value to avoid false restarts.
		Heater DB	10°F	0-54°F	Heater Deadband is activated once the TCU calculates that it is in idle mode (determined by Htr DB Thresh). The deadband is the temperature that the TCU can fluctuate from the setpoint before turning on the heaters and using electro-mechanical contactor life.
		Htr DB Thresh:	900 Fs	1-9999 F/s	The Heater Deadband Threshold is a counter that determines the temperature stability required before the hHeater Deadband will activate.
TCU Setup	3/6	PV Source	To Proc	To Proc From Proc To/From Average	Allows the user to select which RTD temperature probe to user for temperature regulation. The selected signal is sent to the control loop, where it will attempt to reach setpoint.
		PV Smoothing	30 sec	0-720 sec	This can be used to smooth the RTD temperature probe signal. Normally, this should remain in the 0-10 sec range, but can be increased if process fluid is not equi-temperature throughout.
		Low Pres Count	3	1-25	Both of these parameters work hand-in-hand to define the TCU's reaction to multiple process fluid low pressure events while the TCU is in operation. By default, the TCU will tolerate up to 3 process fluid low pressure events every 15 minutes; the TCU will temporarily shutdown during the low pressure event, and automatically restart when the pressure returns. Because excessive, frequent starting/stopping of the TCU can cause motor/pump damage, the purpose of these parameters is to protect the TCU if operating in an environment with unstable fluid pressure.
		Low Pres Time	15 min	1-999 min	
		Units	°F	°F or °C	Used to select your desired temperature unit of measure. After changing, the controller will automatically reboot. Note that this parameter is NOT automatically set to default if the user executes a "Load Defaults" to reset to default parameters.

## User Parameters (Continued)

Category	Screen Number	Parameter (Character Limited)	Default	Range	Description
Venting	4/6	Valve Vent	30 sec	5-180 sec	Upon cold startup, the TCU will flush the process loop with fresh fluid to promote de-aeration. The pump will not run during this time period. Once finished, it will start the pump and continue to flush with the pump's assistance. No loop temperature regulation is performed in this state. Increase this value if you have an excessively long fluid loop.
		Valve/Pmp Vent	30 sec	5-180 sec	Upon cold startup, and after the "Valve Vent" parameter's time period has expired, the TCU will start the pump to assist in de-aeration. No loop temperature regulation is performed in this state. Increase this value if you have an excessively long fluid loop.
		Vent Bypass	120 °F	32-260 °F	If the process loop is above this temperature, the above two venting stages ("Valve Vent" and "Valve/Pmp Vent") will not be performed. This can be used to make machine re-starts quick, while still de-aerating if the machine is started from a cold state.
Control Loop	5/6	System Size	---	Small Normal Large	This setting can be used to quickly select factory-suggested parameters below for P-Band, I-Gain, D-Gain, and Deadband below. Select the setting that best describes your system. Alternatively, you can also directly edit the PID settings below.
		P-Band	7 Δ°F	0.2 - 999.7 Δ°F	Proportional Band for PID temperature control. A smaller number will promote a more aggressive proportional response. At the default 10 Δ°F, this means that the proportional response will be at 100% when the temperature is 10 Δ°F from setpoint.
		I-Gain	25	0-999	Integral Gain for PID temperature control. A smaller number will promote a more aggressive integral response. Zero will disable all integral response.
		D-Gain	10	0-999	Derivative Gain for PID temperature control. A larger number will promote a more aggressive derivative response. Zero will disable all derivative response.
		Deadband	0.5 Δ°F	0-99.9 Δ°F	Defines a region of process temperature deviation that will have no effect in PID control loop. By having a deadband, wear-and-tear on the TCU is minimized because it doesn't have to try as hard to maintain the process temperature perfectly to setpoint.

(Continued)

## User Parameters (Continued)

Category	Screen Number	Parameter (Character Limited)	Default	Range	Description
Additional Settings	6/6	Deviation Actn	Warn	None Warn Alarm	Allows the user to select how the TCU responds to a deviation condition (as defined in screen 1/6 above). <b>Warnings</b> are visible on the screen, but have no affect on machine operation. <b>Alarms</b> shutdown the machine and require user intervention to reset.
		Mold Purge T/O	60 sec	1-999 sec	"After mold purge is started, this is the max time that it can run before being automatically cancelled. Note that the user can stop mold purge at anytime they desire. *Only visible on menu if mold purge option is installed."
		Diagnostics	No	No Yes	Select "Yes" if you would like to enter the diagnostics menu.
		Load Defaults	No	No Yes	Select "Yes" if you would like to load defaults for all user parameters. If you select "Yes", all your customized settings will be permanently lost and default parameters will be used instead. The controller will reboot after implementing default settings.
		Factory Menu	---	---	This is used to enter a password for a factory configuration menu. This is not for user access.



# Factory Parameters

The RQT Standard will not operate correctly if certain factory-set parameters are changed. Parameters should be changed only by qualified technical personnel who are familiar with the operation of this type of equipment.

If the RQT Standard does not appear to be working correctly, verify the parameters against the list of factory settings.

For more detailed information about these parameters and returning parameters to the initial factory setup, *See RQT Standard initial setup, Section 3.*

Category	Screen Number	Parameter (Character Limited)	Default	Range	Description
Included Options	1/4	MP Installed	No	No Yes	Allows the factory to set whether or not mold purge is installed as an option.
		Setpoint Max	250 °F	40-250 °F	Maximum permitted machine setpoint.
		Setpoint Min	40 °F	40-250 °F	Minimum permitted machine setpoint.
		Cool-Heat Rto	1.25	0.1-10.0	Describes the effectiveness of cooling vs effectiveness of heating. Having the correct value here enhances the performance fo the PID algorithm. For example, if the TCU's cooling BTU removal happens at twice the rate of the TCU's heating BTU addition, this number should be set to 2.0. Systems with small heaters and plentiful, cold cooling water may want a value of 1.5. Alternatively, warm cooling water or a very powerful heater would work best with a value of 0.75. A value of 1.0 means there is no distinction between heating/cooling and the PID works in a very traditional manner. Any experimentation to set this value should be done at lower process temperatures.
		Dynamic Mult:	1.75	0.0-10.0	This parameter helps the TCU achieve setpoint quickly and without overshoot across the entire temperature range of operation. This factor multiplies the "Cool-Heat Rto" set in the parameter above at high temperaures. For example, if "Dynamic Mult" is set to 1.75, a Cool-Heat Rto of 1.25 will actually become 2.19 (1.25x1.75=2.19) when the TCU is running at a process temperature of 250°F. Set to zero to disable all dynamic effects, in which case parameter "Cool-Heat Rto" will be solely responsible and at a fixed value across the entire temperature range.

(Continued)

## Factory Parameters (Continued)

Category	Screen Number	Parameter (Character Limited)	Default	Range	Description
Additional Settings	2/4	Cooling Cycle	5.0 sec	0.5-60.0 sec	Time base for solenoid cooling valve. If Cooling Cycle is set to 5.0s, and the unit is cooling at 50% capacity, the solenoid cooling valve will alternate between 2.5s on and 2.5s off.
		Heating Cycle	20.0 sec	0.5-60.0 sec	Time base for heater contactor. If Heating Cycle is set to 10.0s, and the unit is heating at 50% capacity, the heater contactor will alternate between 5.0s on and 5.0s off.
		Hot Pres Relf	Off Δ°F	5-200 Δ°F	The degrees of temperature rise over which the cooling valve will momentarily open to relieve built-up pressure caused by thermal expansion of the process fluid. This should be adjusted to a suggested value of 10Δ°F if a check valve is present on incoming cooling water, and the pressure relief valve intermittently dribbles on the floor as the system warms up.
		Track Health	Yes	No Yes	Provides machine run statistics and alarm counting for the diagnostics menu. This can be disabled to decrease processor load or not track these items.
		Diagnostics	No	No Yes	Select "Yes" to enter the Diagnostics menu. Note: Since you have already authenticated as a factory user, you will have WRITE access to directly control outputs for troubleshooting (except for heater output).
	3/4	Heater			Shows the number of times the heater contactor has actuated.
		MaxOps/hr(x1)	38	0-3600	Defines a maximum number of heater actuations before a warning is presented to the user about too frequent heater contactor usage.
		Warning	7500	0-999999	Number of heater contactor actuations (x100) at which a warning will be produced for the user to replace the worn-out heater contactor.
		Worn Out Acks			Number of times the user has acknowledged the request to replace the worn-out heater contactor.
	4/4	High Temp Alarm	260°F	32-590	Temperature at which a factory high temperature alarm will be triggered.
		Low Temp Alarm	32°F	32-590	Temperature at which a factory low temperature alarm will be triggered.
		Reset Heater	No	No Yes	Resets the accumulated actuations on the heater contactor. Should be set to "Yes" momentarily when replacing a worn- out heater contactor.
		Change Brand	No	No Yes	Change branding.
		Load Defaults	No	No Yes	Select "Yes" if you would like to load defaults for all user AND factory parameters. If you select "Yes", all your customized settings will be permanently lost and default user and factory parameters will be used instead. The controller will reboot after implementing default settings. As a factory user, you will need to then go back and properly configure the factory menu according to the installed TCU options.

# Diagnostics

The RQT Standard is equipped with extensive diagnostic screens to assist the user and/or the factory in:

- Troubleshooting
- Installation
- Preventative maintenance

Category	Screen Number	Parameter (Character Limited)	Input/ Output	Device Description	Description
Digital Inputs	1/19	Pres Swtch[1]	U1	Pressure Switch	Pressure switch input. "ON" when sufficient pressure.
		Pump OL[2]	U2	Pump Overload	Pump overload input. "ON" when not tripped.
		Pump Aux[3]	U3	Pump Contactor Auxiliary Contact	Pump contactor auxiliary contact. "ON" when pump contactor energized and armature seated.
	2/19	Hi Temp[4]	U4	High Temperature Input Jumper	High temperature input. "ON" when no high temperature condition exists.
		Heater Aux[5]	U5	Heater Contactor Auxiliary Contact	Heater contactor auxiliary contact. "ON" when heater contactor energized and armature seated.
		Spare[6]	U6	Spare	Input not used.
Analog Inputs	3/19	Supply RTD[7]	U7	Supply "To Process" RTD	Supply "To Proc" RTD Temperature Probe. Units always in °C.
		Return RTD[8]	U8	Return "From Proc" RTD	Return "From Proc" RTD Temperature Probe. Units always in °C.
		Spare RTD[9]	U9	Spare RTD	Spare RTD Temperature Probe. Units always in °C.
		Spare[10]	U10	Spare	Input not used.
Digital Relay Outputs	4/19	Pump[1]	NO1	Pump Contactor	Pump contactor coil output.
		Heat[2]	NO2	Heater Contactor	Heater contactor coil output.
		Spare[3]	NO3	Spare	Output not used.
	5/19	Cool[4]	NO4	Cooling Solenoid Valve	Cooling solenoid valve coil output.
		Purge[5]	NO5	Purge Solenoid Valve	Purge solenoid valve coil output.
		Alarm[6]	NO6/NC6	Alarm Active Output	Alarm active output.

(Continued)

## Diagnostics (Continued)

Category	Screen Number	Parameter (Character Limited)	Input/ Output	Device Description	Description
Runtime Statistics	6/19	Pump	---	Pump	Pump motor runtime displayed in units of x100 hours. Pump contactor actuations displayed in units of x100 operations.*
		Heater	---	Heater	Heater runtime displayed in units of x100 hours. Heater contactor actuations displayed in units of x100 operations.*
		CV Open	---	Cooling Solenoid Valve	Cooling solenoid valve runtime displayed in units of x100 hours. Cooling solenoid valve actuations displayed in units of x100 operations.*
	7/19	Pres Switch	---	Pressure Switch	Pressure switch input actuations displayed in units of x100 operations.*
		Mold Purge	---	Mold Purge Solenoid	Mold purge solenoid valve coil actuations displayed in units of x100 operations.* Only visible if Mold Purge is installed.
	8/19	Pump OL	---	Pump Overload	Pump overload input trips. The input transitioning to OFF is considered an operation.
		Alarm	---	Alarm Output	Alarm output actuations. The alarm output transitioning to ON is considered an operation.
		High Temp	---	High Temperature Input	High temperature input trips. The input transitioning to OFF is considered an operation.
	9/19	Cooling Water	---	Cooling Water Temperature	The cooling water temperature as measured at the end of the valve vent during normal TCU startup. Value is saved through power cycles and is overwritten at startup during the venting sequence.
		Cooling LTA-%	---	Cooling Utilization Long-Term Average Percent	Displays the average utilized cooling capacity of the TCU since powerup and since setpoint was achieved and reasonably maintained. Can be used to determine approximate long term cooling loads, TCU potential cooling capacity, and utility costs. This value will be erased if power is cycled or the setpoint is changed.
		Heating LTA-%	---	Heating Utilization Long Term Average Percent	Displays the average utilized heating capacity of the TCU since powerup and since setpoint was achieved and reasonably maintained. Can be used to determine approximate long term heating loads, TCU potential heating capacity, and utility costs. This value will be erased if power is cycled or the setpoint is changed.
	9/19	Lst Alm Dur-s	---	Last Alarm Duration in Seconds	How long the machine was in an alarm state. It counts from the initiation of an alarm to the remedying of the condition (for auto-resetting alarms) or the manual reset of the alarm by an operator (for non-auto-resetting alarms).
		Low Pres-hrs	---	Low Pressure Hours	The number of hours the machine was in a running mode, but had turned off the pump because it was waiting for sufficient pressure to be restored to the system.

## Diagnostics (Continued)

Category	Screen Number	Parameter (Character Limited)	Input/ Output	Device Description	Description
Runtime Statistics (cont'd)	10/19	Mem W-x10000	---	Memory Writes	The number of times the memory has been written to. Shown in units of x10,000.
		Loop Time-ms	---	PLC Loop Time	How long it takes the controller to run the entire program and loop back around to begin again. PID loop is updated only once per second regardless of this value.
		Max Lp Tme-ms	---	Max PLC Loop Time	The maximum recorded controller loop time once the controller had loaded all initial parameters.
		PS Volts-V	---	Power Supply Voltage	Incoming power supply voltage.
		PS Freq-Hz	---	Power Supply Frequency	Incoming power supply frequency for AC supply. In the case of a DC supply, this is shown as "0".
Alarm/ Warning Counts	11/19	Sup Probe Srt	---	Supply "To Proc" RTD Temperature Probe Shorted Alarms	Note: Warnings that result from this condition are not counted.
		Ret Probe Srt	---	Return "From Proc" RTD Temperature Probe Shorted Alarms	Note: Warnings that result from this condition are not counted.
	12/19	Sup Probe Opn	---	Supply "To Proc" RTD Temperature Probe Open Alarms	Note: Warnings that result from this condition are not counted.
		Ret Probe Opn	---	Return "From Proc" RTD Temperature Probe Open Alarms	Note: Warnings that result from this condition are not counted.
	13/19	Sup Probe Err	---	Supply "To Proc" RTD Temperature Probe Channel Error Alarms	Note: Warnings that result from this condition are not counted.
		Ret Probe Err	---	Return "From Proc" RTD Temperature Probe Channel Error Alarms	Note: Warnings that result from this condition are not counted.
	14/19	Pmp Stuck Clsd	---	Pump Contactor Stuck Closed Alarms	Number of times pump contactor auxiliary contacts remained actuated when the coil was de-energized.
		Pmp Stuck Open	---	Pump Contactor Stuck Open Alarms	Number of times pump contactor auxiliary contacts remained open when the coil was energized.
		Htr Stuck Clsd	---	Heater Contactor Stuck Closed Alarms	Number of times heater contactor auxiliary contacts remained actuated even the coil was de-energized.
		Htr Stuck Open	---	Heater Contactor Stuck Open Alarms	Number of times heater contactor auxiliary contacts remained open when the coil was energized.
	15/19	Low Pres Time	---	Low Pressure Shut-down Alarms	Number of times the running TCU has remained in a low-pressure paused state for so long that it created an alarm to turn itself off.
		Low Pres Evnts	---	Low Pressure Events Alarms	Number of times the TCU had an alarm due to too many low-pressure events within the selected time period.
		Pump Overload	---	Pump Overload Alarm Alarms	Note: Warnings that result from this condition are not counted.
		Overtemp	---	Overtemperature Alarms	Number of times the TCU has alarmed due to lack of signal on external high-temperature input.

(Continued)

## Diagnostics (Continued)

Category	Screen Number	Parameter (Character Limited)	Input/ Output	Device Description	Description
Runtime Statistics (cont'd)	16/19	Tmp Ovr Limit	---	Temperature Over Factory Limit Alarms	Number of times the TCU has alarmed due to the process temperature exceeding the factory high limit.
		Tmp Und Limit	---	Temperature Under Factory Limit Alarms	Number of times the TCU has alarmed due to the process temperature dropping below the factory low limit.
		Tmp Ovr Setng	---	Temperature Over User Limit Alarms	This is a user-influenced alarm since the user picks the alarm trip points.
		Tmp Und Setng	---	Temperature Under User Limit Alarms	This is a user-influenced alarm since the user picks the alarm trip points.
	17/19	Flash Memory	---	Flash Memory Warnings	Number of times an "excessive number of memory writes" were detected.
		Brownout	---	Brownout Alarms	Number of times the machine lost power while running. This will only register if user turns this alarming on. Note: This functionality is not available on all TCU models.
Electric Power		---	Electric Power Alarms	Number of times the machine detected incorrect incoming power phase rotation or unequal phase legs. Note: This functionality is not available on all TCU models.	
Temperature Loop Monitor	The parameters below are used to monitor the action of the PID temperature control loop. These values are intended for use only by trained individuals for troubleshooting and loop tuning purposes.				
	18/19	P:	---	Proportional Output Contribution	The component of the PID output generated from proportional control.
		I:	---	Integral Output Contribution	The component of the PID output generated from integral control. A $\uparrow$ symbol means this value is free to change because the integrator is active; alternatively a $\bullet$ symbol means the integrator value is frozen due to output saturation (anti-windup), or a large difference between process value and setpoint.
		D:	---	Derivative Output Contribution	The component of the PID output generated from derivative control.
		x	---	Output Multiplier	This multiplier is applied to the sum of the P, I, and D contributions to generate the output percentage. It dynamically changes in proportion to the difference between cooling water temperature and process temperature. The aggressiveness of this multiplier is set by the factory parameter "Cool-Heat Rto".
		→	---	Output Percentage	The final output of the PID loop. This value drives the PWM generator for either the cooling valve or heater. Note that PWM generator outputs under 5% are rounded to 0%, and output above 95% are rounded to 100%.
		To: / From: / Avg:	---	Process Value	The current process value. By default, the controlling process value, as determined by user parameter "PV Source" will be shown. However, you can temporarily view the other RTD temperature probe values by pressing the ←key (this will not alter which RTD is actually controlling the PID loop). The display will revert back to the controlling RTD after several seconds.
		SP:	---	Setpoint	Process setpoint. This can be modified by pushing the $\uparrow$ or $\downarrow$ keys.
		Err:	---	Error Signal	This is the difference between the process value and the setpoint. Ultimately, the goal of the control loop is to reduce this to 0° during operation.

## Diagnostics (Continued)

Category	Screen Number	Parameter (Character Limited)	Input/ Output	Device Description	Description
Versions	19/19	Disp HW Ver:	---		
		Disp FW Ver:	---		
		OS Ver:	---		
		Software Ver:	---		
*One on/off cycle is equal to one operation					

## PID Parameters

The Thermal Care RQT Standard features a PID (“proportional-integral-derivative”) control-loop algorithm implemented in the temperature controller. This algorithm is used to achieve the proper temperature of the process fluid quickly and accurately. The following paragraphs describe its operation.

The default factory PID parameters loaded into the RQT Standard should work well under most applications. However, due to a wide variety of situations and system requirements, these parameters can be adjusted to best serve a particular application.

PID Default Parameters			
	Default	Controller Parameter	Comments
Proportional band	7.0 Δ°F	PID P-Band	Smaller number = more aggressive proportional cooling response.
Integral time	10.0	PID I-Gain	Smaller number = more aggressive integral cooling response.
Derivative time	25.0	PID D-Gain	Larger number = more aggressive derivative cooling response.
Proportional band ratio	0.5 Δ°F	Integral Active Band	Integral Active Band defines the band over which the integral response is active. Typically set similar to the proportional band to prevent excessive integral windup.

### Proportional

The main driver for the RQT Standard control loop is the proportional response. Proportional logic is very simple — it selects a heating or cooling level (strength) based on how close the process is to the setpoint.

The proportional parameter defines a band over what range of degrees the temperature controller will taper-off its heating or cooling. Heating/Cooling will be applied at 100% if the process temperature is more than the band parameter away from the setpoint. A smaller number will produce a more aggressive proportional response because it will shrink the band.

If the RQT Standard is not providing a strong enough heating or cooling response for a given situation, this parameter number should be made more aggressive (a smaller number should be used).

## PID Parameters (Continued)

### Integral

Using only proportional control will cause the RQT Standard to have steady-state error (it will never exactly reach setpoint). Integral response is used to eliminate this undesirable condition.

Integral logic introduces the awareness of the passage of time into the logic by looking into the past—and observing how far the process has been from the setpoint over time. The farther away the process is from setpoint for a longer and longer time, the more it causes the RQT Standard to produce a stronger counter-response. Integral action is internally disabled whenever the RQT Standard is further from the setpoint than the Integral Active Band because it has no merit under this condition.

A smaller number will produce a more aggressive integral response. However, “0” will completely turn off integral response.

If the process temperature is approaching the setpoint too slowly, a stronger integral response (a smaller parameter number) can be used to remedy the situation. Too much integral response can cause the RQT Standard temperature to severely oscillate.

### Derivative

Derivative response is used to eliminate overshoot. It is also used to compensate for the slow-responding modulating valve option. Like integral logic, it is aware of the passage of time—it looks forward into the future and anticipates if the machine will be overshooting the setpoint at some point in the future, based on current trends.

A larger number will produce a more aggressive derivative response.

If the system temperature is overshooting the setpoint, try a more aggressive derivative response. If the system stutters or temporarily reverses temperature direction as approaching setpoint, your derivative response is too aggressive. If overshoot is not a concern, or you have a very large system, derivative control can be completely turned off by setting the parameter to “0” without negative consequences.

### Manual Tuning Procedure

If you find yourself in a situation where the RQT Standard is responding in an unpredictable manner, follow the procedure below to simplify the control loop and pick appropriate PID parameters.

#### PREREQUISITES:

- Your cooling water must be at a reasonably stable temperature and pressure.
- Your external heat load on the RQT Standard must be reasonably constant.
- Select a setpoint for tuning that is similar to a typical setpoint for the process.
- You must have sufficient time to run your system through several thermal cycles in order to perform a full tuning.



# PID Parameters (Continued)

## STEPS:

### To Set Default PID Parameters

- 1 Access User Parameters window by tapping on the button corresponding to the wrench icon and then using the left right arrows to navigate to the 8th window screen.
- 2 Use the “enter” button to move down the menu to Load Defaults. Then use the up and down arrows to select “Yes” under the Load Defaults menu item.

### To Start a Test

- 1 Navigate to the PID settings under the User Parameters window screen 7.
- 2 Turn off all derivative control by setting the D-Gain to “0”.
- 3 Minimize integral control by setting the I-Gain to “0”.
- 4 Set P-Gain to an initial value of approximately 10% of setpoint.

### Run a Test – Proportional

- 1 Start the RQT Standard and observe it attempting to reach setpoint.
- 2 To access the screen to modify the PID band parameters, go to screen 7 of the user parameters window.
- 3 Decrease the PID-P Band until the system begins to oscillate around the setpoint. The PID P-Band is the temperature band over which the PID proportional response will be 100%. A smaller value produces a more aggressive PID proportional response. Example: if set to “5”, the unit will provide 100% cooling/heating response when 5 degrees away from setpoint.

 **NOTE:** You may have to cool down your system and repeat the experiment several times so you can accurately observe the process temperature approaching setpoint.

- 4 Multiply the value determined by Step 3 by “2” and enter it as the new P-Band.

### Continue the Test - Proportional + Integral.

- 5 Integral Active Band defines the band over which the integral response is active. This is typically set to a similar value as the proportional band to prevent excessive integral windup.
- 6 Integral gain for the PID controller. A smaller number will produce a more aggressive integral response. Zero will disable all integral response..
- 7 Finished
- 8 You should review your work and make sure your system is not on the verge of oscillating. If your system oscillates intermittently, you probably have your gains too aggressive. It is better to be mild in your tuning than over-aggressive.
- 9 You are now finished tuning your system. Be sure to record your parameters  $band$ ,  $dEr$ ,  $Int$ ,  $PbH$ ,  $dEH$ ,  $IntH$ . The parameters may need to be tweaked if your system or setpoint changes significantly.

*This page intentionally left blank.*

# Appendix C

## Plumbing Diagrams

### Direct Injection RQT Standard

In a direct injection arrangement, the cooling fluid is directly injected into the process loop whenever cooling is required. The immersion heater provides heat directly into the process fluid whenever needed.

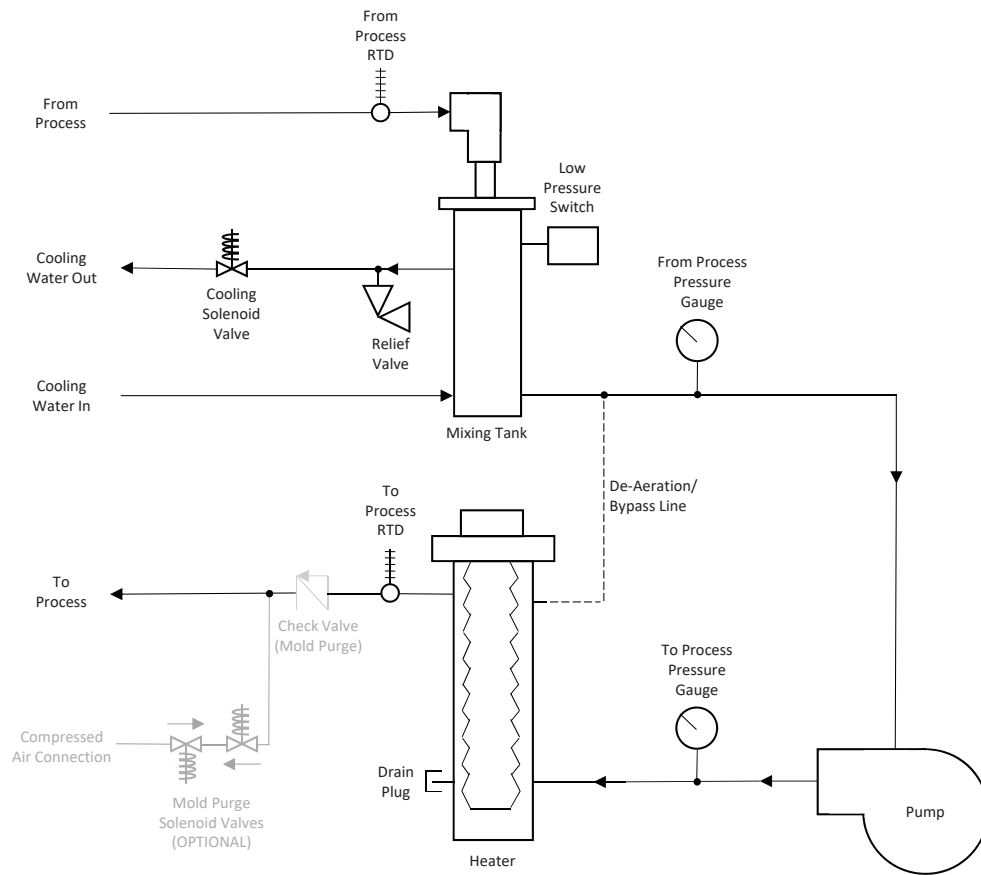

Revised 7-11-22

# Plumbing Diagrams (Cont'd)

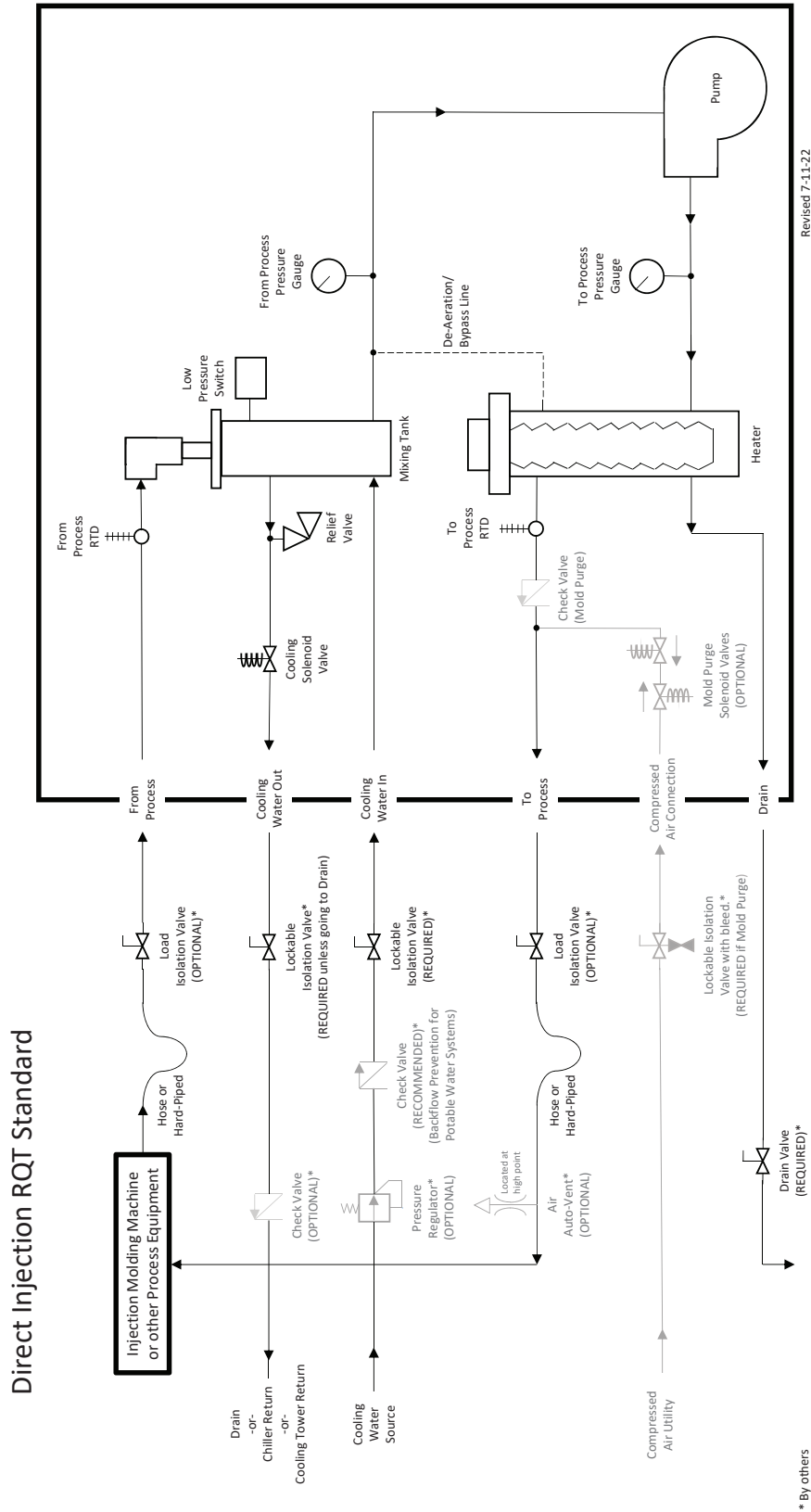

# Appendix D

## Service Parts List

### RQT Standard

**IMPORTANT:** The spare parts list shown in this manual is for guidance and reference only. This list is based on commonly used parts on standard equipment at the time of publication of the manual. Always consult with Thermal Care for the most accurate information when it comes to what parts should be used on your piece of Thermal Care equipment. Having your serial number available when you contact Thermal Care ensures that you get the correct parts for your equipment.

Manuals	
PART NUMBER	DESCRIPTION
TUGH0003 -1022	User Guide, RQT Standard

PUMP ASSEMBLIES	HP	VOLTAGE	POWER FREQUENCY
<b>PART NUMBER</b>			
2672030104	3/4	208-230/460	60
2672030304	2	208-230/460	60
<b>MOTOR (ONLY)</b>			
2672030000A2	3/4	208-230/460	60
2672030000A4	2	208-230/460	60
<b>VOLUTE/CASING</b>			
2672030000E4	3/4	208-230/460	60
2672030000E5	2	208-230/460	60
<b>MOTOR ADAPTERS</b>			
2672030000F3	3/4	208-230/460	60
2672030000F3	2	208-230/460	60
<b>IMPELLERS</b>			
2672030000G8	3/4	208-230/460	60
2672030000G10	2	208-230/460	60
<b>SEAL KITS</b>			
267203SK0101	3/4		
267203SK0101	2		

Contact Thermal Care Parts  
Phone: 847-966-8560

For replacement heater and pump contactor, please see the bill of material on the electrical print in order to select the correct part number for your operating voltage and horsepower.

*This page intentionally left blank.*



5680 W. Jarvis Ave. • Niles, IL 60714  
847-966-2260  
[www.thermalcare.com](http://www.thermalcare.com)

**New Equipment Sales**  
847-966-2260  
[sales@thermalcare.com](mailto:sales@thermalcare.com)

**Customer Service**  
847-966-2636  
[tcservice@thermalcare.com](mailto:tcservice@thermalcare.com)

**Parts Department**  
847-966-8560  
[tcparts@thermalcare.com](mailto:tcparts@thermalcare.com)