



# Temperature Controllers

OPERATION,  
INSTALLATION AND  
MAINTENANCE  
MANUAL

Aquatherm RQT  
Premium

Where water  
means business.



Please record your equipment's model and serial number(s) and the date you received it in the spaces provided.

It's a good idea to record the model and serial number(s) of your equipment and the date you received it in the User Guide. Our service department uses this information, along with the manual number, to provide help for the specific equipment you installed.

Please keep this User Guide and all manuals, engineering prints, and parts lists together for documentation of your equipment.

Date:

---

Serial Number(s):

---

Model Number(s):

---

**DISCLAIMER:** Neither Thermal Care nor its employees shall be liable for errors contained in this User Guide or for incidental, consequential damages in connection with the furnishing, performance or use of this information. Thermal Care makes no warranty of any kind with regard to this information, including, but not limited to, the implied warranties of merchantability and fitness for a particular purpose.

# Table of Contents

## 1-1 Introduction

Purpose of the User Guide .....	1-2
How the Guide is Organized .....	1-2
Your Responsibility as a User .....	1-2
Foreword .....	1-3
ATTENTION: Read This So No One Gets Hurt.....	1-4
Zero Energy State (ZES) .....	1-5
How to Use the Lockout Device .....	1-6

## 2-1 Description

What is the RQT Premium .....	2-2
Typical Applications .....	2-2
How the RQT Premium Direct Injection Works .....	2-4
How the Closed Circuit Common Source Works.....	2-5
How the Closed Circuit Separate Source Works .....	2-6
RQT Premium Control Features vs RQT Standard and RQT Advanced .....	2-7
Specifications: RQT Premium .....	2-8

## 3-1 Installation

Unpacking the Boxes .....	3-2
Preparing for Installation .....	3-3
Fluid Distribution Piping.....	3-6
Installation - Electrical .....	3-7
Connecting Process and Water Supply Lines <u>Without</u> Purge .....	3-8
Connecting Process and Water Supply Lines <u>With</u> Optional Mold Purge Valve Connections .....	3-9
Connecting the Main Power Source .....	3-10
Program Menu Accessibility .....	3-11
Testing the Installation.....	3-12
Altitude, Fluid Type, and Units of Measure .....	3-14

Setpoint.....	3-15
Setting Process Value Source.....	3-15
Setting Up Your Controller.....	3-16

## 4 - 1 Operation

The RQT Premium Control.....	4-2
Start-up .....	4-4
Starting the RQT Premium.....	4-5
Stopping the RQT Premium.....	4-6
Program Menu Accessibility.....	4-7
SPI Communications (Optional) .....	4-8
SPI Option Parameters .....	4-10
Normal Operation .....	4-10
Operation of the Screen Saver.....	4-10
Auto Cool Stop Sequence Initiation .....	4-12
Using the Mold Purge Option .....	4-12
System Maintenance.....	4-14

## 5 - 1 Maintenance

Maintenance of Your RQT Premium .....	5-2
Preventative Maintenance Schedule .....	5-2
Accessing the RQT Premium Enclosure.....	5-3
Removing the Pump Motor and Seal (3/4-2 HP, any frequency and 3 HP, 60 Hz units).....	5-4
Reassembling the Pump Motor and Seal (3/4-2 HP, any frequency and 3 HP, 60 Hz units) .....	5-7
Removing the Pump Motor and Seal (3 HP, 50Hz and 5 to 10 HP, any frequency units) .....	5-9
Reassembling Pump Motor and Seal (3 HP, 50Hz and 5 to 10 HP, any frequency units) .....	5-11
Resetting Pump Overload.....	5-12
Replacing Pump Overload.....	5-12
Replacing the Heater Contactor .....	5-13

Replacing the Controller Boards.....	5-14
B&R IO Card Replacement/Additions .....	5-15

## 6 - 1 Troubleshooting

Before Beginning.....	6-2
A Few Words of Caution.....	6-3
Identifying the Cause of a Problem .....	6-4
Controller Warnings .....	6-5
Controller Alarms.....	6-8
Unit Will Not Power Up.....	6-15
Troubleshooting .....	6-16
Checking the RTD .....	6-18
Replacing RTDs.....	6-20
Repairing Cooling Valves.....	6-21
Replacing Immersion Heaters.....	6-22
Removing the Pump .....	6-26
Timecode Retrieval Procedure.....	6-27

## A Appendix

We're Here to Help.....	A-1
How to Contact Customer Service .....	A-1
Before You Call.....	A-1

## B Appendix

PID Parameters.....	B-1
---------------------	-----

## C Appendix

Plumbing Diagram.....	C-1
Plumbing Curves .....	C-7

<b>D</b>	<b>Appendix</b>	
	External Interfaces.....	D-1
<b>E</b>	<b>Appendix</b>	
	Flowmeter Installation Instruction Sheet.....	E-1

# Introduction

---

Purpose of the User Guide .....	1-2
How the Guide is Organized .....	1-2
Your Responsibility as a User .....	1-2
Foreword .....	1-3
ATTENTION: Read This So No One Gets Hurt .....	1-4
Zero Energy State (ZES).....	1-5
How to Use the Lockout Device .....	1-6





# Purpose of the User Guide

This User Guide describes the Thermal Care RQT Premium and explains step-by-step how to install and operate this equipment.

Before installing this product, please take a few moments to read the User Guide and review the diagrams and safety information in the instruction packet. You also should review manuals covering associated equipment in your system. This review won't take long, and it could save you valuable installation and operating time later.

# How the Guide is Organized

Symbols have been used to help organize the User Guide and call your attention to important information regarding safe installation and operation.

-  Symbols within triangles warn of conditions that could be hazardous to users or could damage equipment. Read and take precautions before proceeding.
- 1** Numbers indicate tasks or steps to be performed by the user.
-  A diamond indicates the equipment's response to an action performed by the user or a situation.
-  An open box marks items in a checklist.
- A circle marks items in a list.
-  Indicates a tip. A tip is used to provide you with a suggestion that will help you with the maintenance and the operation of this equipment.
-  Indicates a note. A note is used to provide additional information about the steps you are following throughout the manual.

# Your Responsibility as a User

You must be familiar with all safety procedures concerning installation, operation, and maintenance of this equipment. Responsible safety procedures include:

- Thorough view of this User Guide, paying particular attention to hazard warnings, appendices, and related diagrams.
- Thorough review of the equipment itself, with careful attention to voltage sources, intended use, and warning labels.
- Thorough review of instruction manuals for associated equipment.
- Step-by-step adherence to instructions outlined in this User Guide.



## Foreword

The RQT Premium typically consists of a fluid pump, electric immersion heater, and temperature control valve in a compact packaged cabinet for easy location in industrial applications where fluid temperature control is required.

This manual is to serve as a guide for installing, operating, and maintaining the equipment. Improper installation can lead to poor performance and/or equipment damage. We recommend the use of qualified installers and service technicians for all installation and maintenance of this equipment.

This manual is for our standard product. The information in this manual is general in nature. Unit-specific drawings and supplemental documents are included with the equipment as needed. Additional copies of documents are available upon request. We strive to maintain an accurate record of all equipment during the course of its useful life.

Due to the ever-changing nature of applicable codes, ordinances, and other local laws pertaining to the use and operation of this equipment, we do not reference them in this manual. There is no substitute for common sense and good operating practices when placing any mechanical equipment into operation. We encourage all personnel to familiarize themselves with this manual's contents. Failure to do so may unnecessarily prolong equipment down time.

Follow good piping practices and the information in this manual to ensure successful installation and operation of this equipment.

We trust your equipment will have a long and useful life. If you should have any questions, please contact our Customer Service Department specifying the serial number and model number of the unit as indicated on the nameplate.

# ATTENTION:

## Read This So No One Gets Hurt

We design equipment with the user's safety in mind. You can avoid the potential hazards identified on this machine by following the procedures outlined below and elsewhere in the User Guide.



**WARNING: Improper installation, operation, or servicing may result in equipment damage or personal injury.**



This equipment should be installed, adjusted, and serviced by qualified technical personnel who are familiar with the construction, operation, and potential hazards of this type of machine.

All wiring, disconnects, and fuses should be installed by qualified electrical technicians in accordance with electrical codes in your region. Always maintain a safe ground. Do not operate the equipment at power levels other than what is specified on the machine serial tag and data plate.



**WARNING: Voltage Hazard**



This equipment is powered by three-phase alternating current, as specified on the machine serial tag and data plate.

A properly sized conductive ground wire from the incoming power supply must be connected to the chassis ground terminal inside the electrical enclosure. Improper grounding can result in severe personal injury and erratic machine operation.

Always disconnect and lock out the incoming main power source before opening the electrical enclosure or performing non-standard operating procedures, such as routine maintenance. Only qualified personnel should perform troubleshooting procedures that require access to the electrical enclosure while power is on.



**WARNING: Compressed Air Hazard**

If you use compressed air, you must wear eye protection and observe all OSHA and other safety regulations pertaining to the use of compressed air. Bleed off pressure before servicing equipment.



**CAUTION: Hot Surfaces**



Surface temperatures inside the RQT Premium can exceed 300°F {149°C}. Always allow the unit to cool below 100°F {38°C} before opening, servicing, or disassembling the unit.

## Zero Energy State (ZES)



**CAUTION:** Before performing maintenance or repairs on this product, you should disconnect and lockout electrical power sources to prevent injury from unexpected energizing or start-up.

During maintenance, it is essential that the system be put into a state which eliminates the possibility of components making an unexpected and dangerous movement. This procedure is typically referred to as lockout. After all energy sources have been neutralized, the system is in the zero mechanical state (ZMS). This provides maximum protection against unexpected mechanical movement.

The lockout procedure must include all energy sources:

- Electrical power supply
- Compressed air supply
- Potential energy from suspended parts
- Pressurized process fluid loop
- Cooling fluid supply
- Cooling fluid return
- Stored thermal energy
- Any other source that might cause unexpected mechanical movement or energy release

The following is a recommended Zero Energy State procedure which must be followed prior to any inspection, or maintenance of the TCU.

- 1 Turn off the all devices attached to the RQT Premium.**
- 2 Perform the proper shutdown sequence to the connected equipment** and allow all components (internally and externally) to adequately cool.
- 3 Disconnect and lock out the primary electrical supply feeding all attached components.**



**WARNING:** Before removing lockout devices and returning switches to the ON position, make sure that all personnel are clear of the machine, tools have been removed and all safety guards reinstalled.

- 4 Disconnect and lock out the compressed air supply** (if equipped).
- 5 Isolate the RQT Premium from other fluids in the system**, such as the main process loop and the cooling fluid supply and return.
- 6 Bleed off fluid pressure that may be present in the various fluid containing portions of the RQT Premium**, keeping in mind that pressure can be the result of increased temperatures.

# How to Use the Lockout Device

 **CAUTION:** Before performing maintenance or repairs on this product, you should disconnect and lockout electrical power sources to prevent injury from unexpected energization or start-up. A lockable device may be provided to isolate this product from potentially hazardous electricity.

 **WARNING:** Before removing lockout devices and returning switches to the ON position, make sure that all personnel are clear of the machine, tools have been removed and all safety guards are reinstalled.

**Lockout** is the preferred method of isolating machines or equipment from energy sources. Your Thermal Care product may be equipped with the lockout device pictured below. To use the lockout device:

- 1 Stop or turn off the equipment.**
- 2 Isolate the equipment from the electric power by turning the rotary disconnect switch to the OFF, or “O” position**
- 3 Secure the device with an assigned lock and/or tag.**
- 4 The equipment is now locked out.**

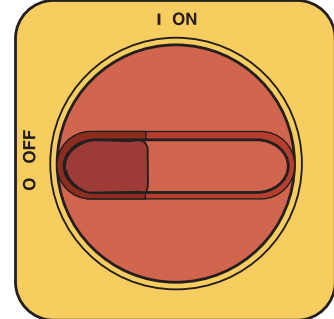
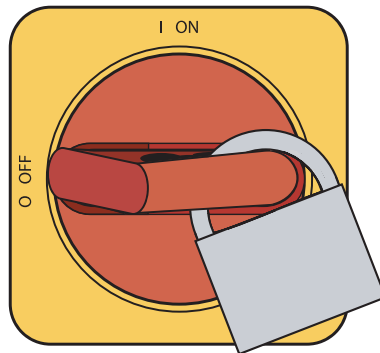
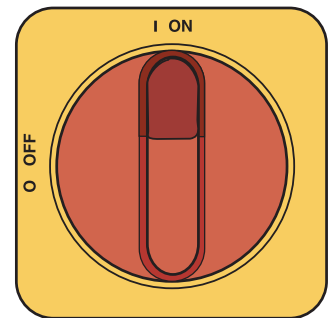

If the machine has no included lockout device, perform the same procedure at the upstream device as part of premises electrical system. Incoming cooling water and compressed air (if purge) are additional energy sources that need to be controlled in a similar manner.

 **NOTE:** The incoming power wires on the top of the disconnect switch are still energized, even when the machine is locked out. It is strongly recommended that electrical energy also be locked out at the next upstream device if work is going to be performed in the electrical panel.

# Description

---

What is the RQT Premium ..... 2-2

Typical Applications ..... 2-2

How the RQT Premium Direct Injection Works..... 2-4

How the Closed Circuit Common Source Works..... 2-5

How the Closed Circuit Separate Source Works..... 2-6

RQT Premium Control Features vs RQT Standard and  
 RQT Advanced ..... 2-7

Specifications: RQT Premium ..... 2-8

# What is the RQT Premium

The RQT Premium Series circulates water at a temperature higher than the available water supply. It will add or remove heat as needed to maintain a uniform temperature setpoint in the process.

The RQT Premium Series is available in single or multiple-zone configurations for process heating and cooling. Two-zone models can control up to two temperatures at different locations in the process. Two-zone models have common cooling water manifolds and electrical connections.

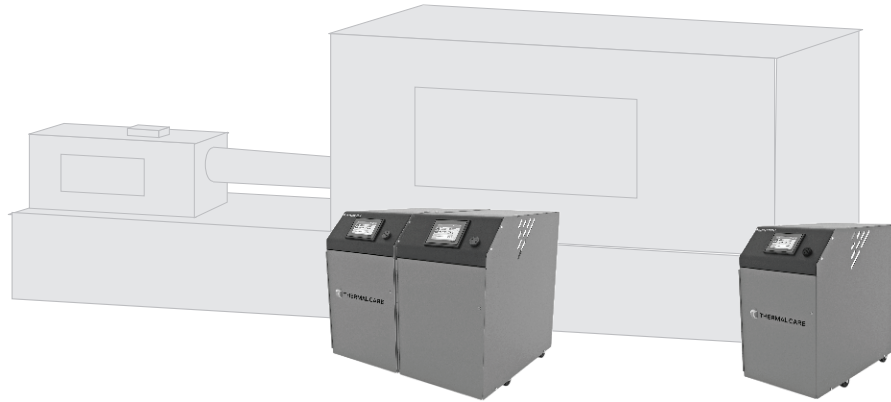

## Typical Applications

The best model for your application depends on the process temperature you need to maintain and the quality of the cooling water supply.

RQT direct injection (DI) models control the temperature by discharging heated process water and adding cooling water directly from the water supply. DI models are designed for:

- Process temperatures up to 250°F {121°C} - with options up to 300°F {149°C}.
- Use with chiller water or properly treated and filtered tower or city water.

Check to make sure all piping connections are secure and that all lines are suitable for water or the coolant in the system at the maximum setpoint temperature and cumulative pressure rating of the maximum pump pressure rise, plus the cooling water pressure.

Make sure that the cooling source is the appropriate temperature and pressure for your application. In most cases, the cooling source is between 40°F {4°C} and 85°F {29°C}. The minimum cooling source fluid pressure must be at least 30 PSI\* in order for the unit to start. The maximum pressure is shown in this chart in order to meet the pressure limitations of standard 150 psi, high-temperature industrial hose/plumbing on the discharge side of the pump.

Pump HP	Max Cooling (PSI)
3/4	95
1	90
2	90
3	85
5	75
7.5	65
10	50

\*Adaptive Maximum Setpoint allows for operation below 30 PSI. This feature will automatically adjust maximum temperature setpoint based off of supplied pressure with certain heater and pump combinations.

## Typical Applications (Continued)

The limiting factor regarding the maximum cooling pressure is the presumed 150 PSI Rating of industry-standard hose. The hose must be able to withstand the maximum possible process temperature at maximum possible pressure.

Your cooling water pressure may exceed the values shown in the chart ONLY if you are utilizing specialty high-pressure/ high-temperature hose.

All RQT Premium units have pressure transducers, and the software will limit setpoint depending on average cooling source pressure. The pressure relief valve is located on the “From Process” side of the pump, and will start to discharge if the pressure exceeds 135 psi. If this becomes an issue, install a pressure-regulating valve (available from our Parts Department) on the cooling water supply line to help regulate the pressure to ensure it is well below the pressure rating of the pressure relief valve. For further assistance in installing a pressure-regulating valve, please contact our Customer Service Department.

### System Fill Water Chemistry Requirements

The properties of water make it ideal for heat transfer applications. It is safe, non-flammable, non-poisonous, easy to handle, widely available, and inexpensive in most industrialized areas.

When using water as a heat transfer fluid it is important to keep it within certain chemistry limits to avoid unwanted side effects. Water is a “universal solvent” because it can dissolve many solid substances and absorb gases. As a result, water can cause the corrosion of metals used in a cooling system. Additionally, dissolved minerals naturally present in tap water will precipitate out onto the system plumbing at elevated fluid temperatures, forming scale. The life giving properties of water can also encourage biological growth that can foul heat transfer surfaces. *See “Fill Water Chemistry” in the Installation section of this User Guide.*

# How the RQT Premium Series Direct Injection Works

Direct Injection models maintain the process temperature by electrically heating and/or injecting cool water supplied to the RQT Premium by a chiller, tower, or other water source.

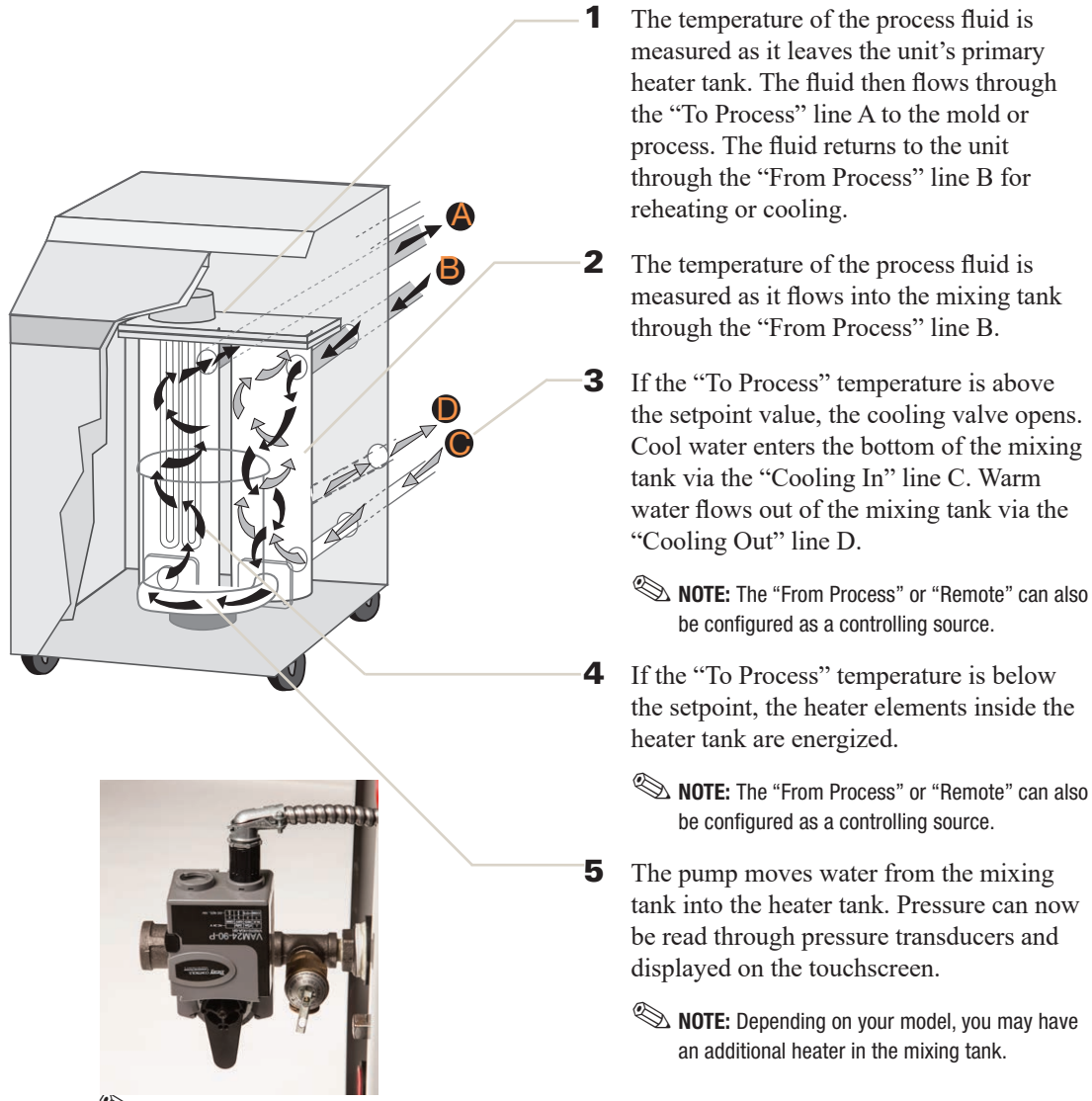

**1** The temperature of the process fluid is measured as it leaves the unit's primary heater tank. The fluid then flows through the "To Process" line A to the mold or process. The fluid returns to the unit through the "From Process" line B for reheating or cooling.

**2** The temperature of the process fluid is measured as it flows into the mixing tank through the "From Process" line B.

**3** If the "To Process" temperature is above the setpoint value, the cooling valve opens. Cool water enters the bottom of the mixing tank via the "Cooling In" line C. Warm water flows out of the mixing tank via the "Cooling Out" line D.

**NOTE:** The "From Process" or "Remote" can also be configured as a controlling source.

**4** If the "To Process" temperature is below the setpoint, the heater elements inside the heater tank are energized.

**NOTE:** The "From Process" or "Remote" can also be configured as a controlling source.

**5** The pump moves water from the mixing tank into the heater tank. Pressure can now be read through pressure transducers and displayed on the touchscreen.

**NOTE:** Depending on your model, you may have an additional heater in the mixing tank.

**NOTE:** The modulating valve will be located on the Cooling OUT line, exiting the RQT.

*Refer to the Direct Injection Plumbing Diagram for the RQT Premium in Appendix C of this User Guide.*



# How the Closed Circuit Common Source Works

Closed Circuit models maintain the process temperature by electrically heating and indirectly cooling fluid in the process circuit. Cooling water supplied by a chiller, tower or other water source, is mixed with the process fluid only during the initial filling or when water is needed to make up process fluid loss. A brazed-plate heat exchanger replaces the mixing tank used on direct injection units.

- 1 The temperature of the process fluid is measured as it leaves the unit’s heater tank. The fluid then flows through the “To Process” line to the mold or process. The fluid returns to the unit through the “From Process” line for reheating or cooling.
- 2 If the temperature is above the setpoint value, the cooling valve opens. Cool water enters the heat exchanger via the “Cooling In” line. Process fluid is always being circulated through the process side of the heat exchanger. The process fluid is indirectly cooled via conduction from the colder water now running through the cooling side of the heat exchanger. If the measured temperature is below the setpoint, the heater elements inside the heater tank are energized.

 **NOTE:** The “From Process” or “Remote” can also be configured as a controlling source.

- 3 The pump moves water from the heat exchanger to the heater tank. Pressure is measured before and after the pump with pressure transducers. If the “To Process” temperature is below the setpoint, the heater elements inside the heating tank are energized.

 **NOTE:** The “From Process” or “Remote” can also be configured as a controlling source.



 **NOTE:** The modulating valve will be located on the Cooling OUT line, exiting the temperature control unit.

*Refer to the Closed Circuit Common Source Plumbing Diagram for the RQT Premium in Appendix C of this User Guide.*

# How the Closed Circuit Separate Source Works

Closed Circuit Separate Source models maintain the process temperature by electrically heating and indirectly cooling fluid in the process circuit. Cooling water supplied by a chiller, tower or other water source, is never mixed with process fluid. Fluid to fill the process loop is provided by a “separate source.” A brazed plate heat exchanger replaces the mixing tank used on direct injection units.

- 1** The temperature of the process fluid is measured as it leaves the unit’s heater tank. The fluid then flows through the “To Process” line to the mold or process. The fluid returns to the unit through the “From Process” line for reheating or cooling.
- 2** If the temperature is above the setpoint value, the cooling valve opens. Cool water enters the heat exchanger via the “Cooling In” line. Process fluid is always being circulated through the process side of the heat exchanger. The process fluid is indirectly cooled via conduction from the colder water now running through the cooling side of the heat exchanger. If the measured temperature is below the setpoint, the heater elements inside the heater tank are energized.

 **NOTE:** The “From Process” or “Remote” can also be configured as a controlling source.

- 3** The pump moves water from the heat exchanger to the heater tank. Pressure is measured before and after the pump with pressure transducers. If the “To Process” temperature is below the setpoint, the heater elements inside the heating tank are energized.

 **NOTE:** The “From Process” or “Remote” can also be configured as a controlling source.



 **NOTE:** The modulating valve will be located on the Cooling OUT line, exiting the RQT Premium.

*Refer to the Closed Circuit Separate Source Plumbing Diagram for the RQT Premium in Appendix C of this User Guide.*

# RQT Premium Control Features vs RQT Std & RQT Advanced

## Touch Screen Control, RQT Premium

### Multi-level User Security

Identify User and Log-in Status

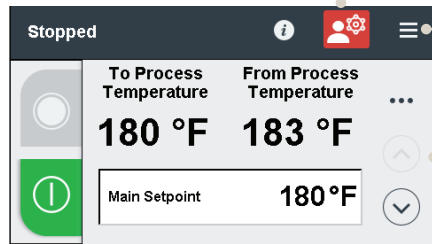

### Simple Menu Operation

Access to all features

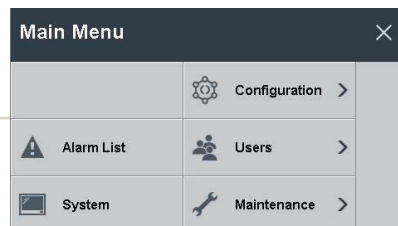

### Touch Screen Display

Large, customizable Home screen display with current temps

### Alarm Lists, History, and Details

Operators can drill down from the Alarm List to the Alarm History and Alarm Details screens to analyze issues. Alarm details are specific, with recommended corrective actions.

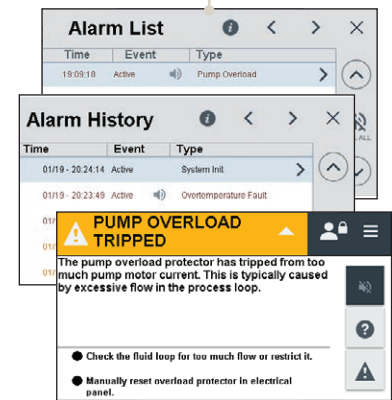

Description 2

### Alarm and Warning Banners

Easy-to-see banners

<b>Warning</b> Yellow	RQT Premium continues running
<b>Alarm</b> Red	Machine shuts down until the condition is corrected

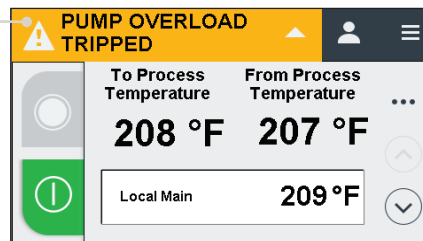

### Contextual Help Mode

On-screen descriptions of features v touched

## Control Features on the RQT Premium

Model	RQT Premium
Direct Injection	●
Closed Circuit - Common Source	○
Closed Circuit - Separate Source	○
<b>Construction</b>	
Standard Pump Range	3/4 to 10 Hp
Standard Heater Range	0 to 48 kW
Cast Heater / Pump	●
Incoloy Heaters	●
Silicon Carbide Seals	●
Pressure Gauges	●
Pressure Transducer	●
Solid State Heater Relays (SSRS)	○
<b>Controls</b>	
PID Control	●
Setpoint / Actual Display	●
Password Protection	●
Modbus-RTU via RS-485	●
Modbus-TCP via Ethernet	●
SPI RS-485 Interface	○
OPC-UA via Ethernet	●
Retransmit Process Temp	●
Auto Restart Capability	●
Mold Purge (Factory Installed)	○
Phase Detection Circuit	●
Choice of Control Points	●
Seal Saver/Auto Cool Stop	●
<b>Status / Alarm Lights</b>	
Audible Alarm	●
Strobe Light	○
Alarm Dry Contacts	○
Remote RTD Support	●
Trending	●

● Standard  
○ Optional

- Purge On/Off button included on control.
- Phase detection indicates incorrect pump rotation or an open electrical leg.
- Control temperature based on temperature at process supply or return points, or an average of the two points.

## Control Features on the RQT Advanced and RQT Standard

Model	RQT Advanced	RQT Standard
Direct Injection	●	●
Closed Circuit - Common Source	○	
Closed Circuit - Separate Source		
<b>Construction</b>		
Standard Pump Range	3/4 to 10 Hp	3/4 or 2 Hp
Standard Heater Range	0 to 48 kW	12 kW
Cast Heater / Pump	●	●
Incoloy Heaters	●	●
Silicon Carbide Seals	●	●
Pressure Gauges		●
Pressure Transducer	●	
Solid State Heater Relays (SSRS)	○	
<b>Controls</b>		
PID Control	●	●
Setpoint / Actual Display	●	●
Password Protection		
Modbus-RTU via RS-485	●	
Modbus-TCP via Ethernet	○	
SPI RS-485 Interface		
OPC-UA		
Retransmit Process Temp	● (0-10 VDC)	
Auto Restart Capability	●	
Mold Purge (Factory Installed)	○	○
Phase Detection Circuit	○	
Choice of Control Points	●	●
Seal Saver/Auto Cool Stop	●	
<b>Status / Alarm Lights</b>		
Audible Alarm	●	
Strobe Light	○	
Alarm Dry Contacts	○	
Remote RTD Support	●	
Trending		

# Specifications: RQT Premium

Models	RQT Premium (direct injection) <sup>†</sup>	RQT Premium(closed circuit) <sup>§</sup>
<b>Performance characteristics</b>		
Minimum setpoint temperature °F (°C)	40 {4} (with 100% water process fluid), optional lower temperatures with various glycol mixtures are available - consult factory.	
Maximum setpoint temperature °F (°C)	250 {121}, {300 {149} optional <sup>††</sup> §§	
Minimum operating temperature °F (°C)	Approximately 20° {11°} above the cooling water inlet temperature <sup>*</sup>	
Standard cooling valve size inches {mm} Cv	1/2 {12.7} (CV=2.9) (varies)	
Available pump sizes	0.75, 1, 2, 3, 5, 7.5, 10 Hp {0.56, 0.75, 1.49, 2.24, 3.73, 5.59, or 7.46 kW} <sup>***</sup>	
Available heater sizes	0, 9, 12, 18, 24, 36 or 48 kW	0, 9, 12, 18, 24, or 36 kW
Connections to/from process NPT (female)	1.50 inches	
Connections in/out cooling water NPT (female)	1.00 inches	

**Pump performance** - Consult factory for pump performance characteristics at other operating points.

Pump	3/4 Hp {0.56 kW}	1 Hp {0.75 kW}	2 Hp {1.49 kW}	3 Hp {2.24 kW}	5 Hp {3.73 kW}	7.5 Hp {5.59 kW}	10 Hp {7.46 kW}
Nominal flow gpm {lpm}	50 {189}	55 {208}	75 {284}	85 {322}	100 {379}	120 {454}	150 {568}
Pressure @ nominal flow psi {kg/cm <sup>2</sup> } <sup>††</sup>	20 {1.4}	25 {1.7}	30 {2.1}	32 {2.2}	46 {3.2}	56 {3.9}	65 {4.5}

<b>Dimensions</b> inches {mm} <sup>††</sup>				
Cabinet style	Single Zone Small (A)	Single Zone Large (A)	Dual Zone Small (B)	Dual Zone Large (B)
Height	24.98{634}	28.98 {735}	24.98 {635}	28.98 {736}
Width	14.09 {358}	14.09 {358}	28.41 {722}	28.41 {722}
Depth	24.09 {612}	26.09 {663}	24.09 {612}	26.09 {663}

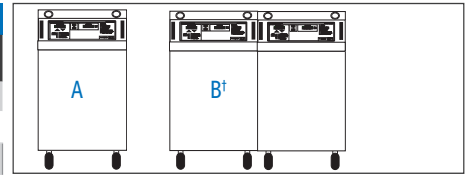

**Shipping weight ranges** lb {kg} Weights vary depending on cabinet size, options, and cooling type (DI or CC).

Pump	Single Zone				Dual Zone			
	Minimum	Maximum	Minimum	Maximum				
0.75 Hp {0.56 kW}	240 {109}	280 {127}	491 {223}	576 {261}				
1 Hp {0.75 kW}	245 {111}	290 {132}	499 {226}	584 {265}				
2 Hp {1.49 kW}	248 {113}	298 {135}	515 {234}	590 {268}				
3 Hp {2.24 kW}	259 {118}	299 {136}	538 {244}	623 {283}				
5 Hp {3.73 kW}	302 {137}	352 {160}	629 {285}	699 {317}				
7.5 Hp {5.59 kW}	317 {144}	362 {164}	649 {294}	729 {331}				
10 Hp {7.46 kW}	329 {149}	379 {172}	683 {310}	763 {346}				

**Total full load amps per zone** §

Heater	9 kW				12 kW				18 kW			
	460/3/60	208-230/3/60	575/3/60	400/3/50	460/3/60	208-230/3/60	575/3/60	400/3/50	460/3/60	208-230/3/60	575/3/60	400/3/50
<b>Pump size</b>												
0.75 Hp {0.56 kW}	12.9	25.8	10.4	14.9	16.7	33.3	13.4	19.2	24.2	48.4	19.5	27.9
1.0 Hp {0.75 kW}	13.2	24.3	10.5	16.0	17.0	34.0	13.5	20.3	24.5	49.1	19.6	29.0
2.0 Hp {1.49 kW}	14.4	28.7	11.5	17.1	18.2	36.2	14.5	21.4	25.7	51.3	20.6	30.1
3.0 Hp {2.24 kW}	15.5	31.5	12.4	18.1	19.3	39.0	15.4	22.4	26.8	54.1	21.5	31.1
5.0 Hp {3.73 kW}	17.6	36.1	14.0	20.6	21.4	43.6	17.0	24.9	28.9	58.7	23.1	33.6
7.5 Hp {5.59 kW}	20.2	41.1	15.9	24.9	24.0	48.6	18.9	29.2	31.5	63.7	25.0	37.9
10.0 Hp {7.46 kW}	23.6	N/A	18.8	N/A	27.4	N/A	21.8	N/A	34.9	N/A	27.9	N/A

**Total full load amps per zone** \*\*

Heater	24 kW				36 kW				48 kW			
	460/3/60	208-230/3/60	575/3/60	400/3/50	460/3/60	208-230/3/60	575/3/60	400/3/50	460/3/60	208-230/3/60	575/3/60	400/3/50
<b>Pump size</b>												
0.75 Hp {0.56 kW}	31.7	63.4	25.5	36.5	46.8	N/A	37.5	N/A	61.8	N/A	49.6	N/A
1.0 Hp {0.75 kW}	32.0	64.1	25.6	37.6	47.1	N/A	37.6	N/A	62.1	N/A	49.7	N/A
2.0 Hp {1.49 kW}	33.2	66.3	26.6	38.7	48.3	N/A	38.6	N/A	63.6	N/A	50.7	N/A
3.0 Hp {2.24 kW}	34.3	69.1	27.5	39.7	49.4	N/A	39.5	N/A	64.4	N/A	51.6	N/A
5.0 Hp {3.73 kW}	36.4	73.7	29.1	42.2	51.5	N/A	41.1	N/A	66.5	N/A	53.2	N/A
7.5 Hp {5.59 kW}	39.0	78.7	31.0	46.5	54.1	N/A	43.0	N/A	69.1	N/A	55.1	N/A
10.0 Hp {7.46 kW}	42.4	N/A	33.9	N/A	57.5	N/A	45.9	N/A	72.5	N/A	58.0	N/A

## Specification Notes

- \* Lower operating temperatures can be obtained with larger cooling valves.
  - † Available in Premium and Advanced models only.
  - ‡ Direct Inject (DI) cooling injects cooling water directly into the process loop upon demand.
  - § Closed Circuit Common Source (CCCS) cooling injects cooling water in the process loop only during the initial filling or when make-up water is needed. Closed Circuit Separate Source maintains separation via heat exchanger between the cooling and process fluids at all times.
  - \*\* FLA data for reference purposes only. Does not include any options/accessories on equipment. For full FLA detail of specific machines/systems, refer to the electrical diagrams of the equipment order and the nameplate applied. Note: 208V units will consume less than the 230V FLA values shown in the chart.
  - †† 300°F units require 75 psi minimum inlet cooling source pressure to operate at the highest temperature at sea level. Higher elevations will require slightly more pressure.
  - ‡‡ Smaller frame only available on 3/4HP-3HP units with 0-18kW Heater option
  - §§ With sufficient cooling water pressure
  - \*\*\* 10 HP not available for 50Hz
- Specifications may change without notice. Consult factory for the most current information.

# Installation

---

Unpacking the Boxes .....	3-2
Preparing for Installation .....	3-3
Fluid Distribution Piping .....	3-6
Installation - Electrical .....	3-7
Connecting Process and Water Supply Lines <u>Without</u> Purge.....	3-8
Connecting Process and Water Supply Lines <u>With</u> Optional Mold Purge Valve Connections....	3-9
Connecting the Main Power Source .....	3-10
Program Menu Accessibility .....	3-11
Testing the Installation.....	3-12
Altitude, Fluid Type, and Units of Measure.....	3-14
Setpoint .....	3-15
Setting Process Value Source.....	3-15
Setting Up Your Controller .....	3-16

# Unpacking the Boxes

RQT Premium models come fully assembled.\* If it was specified at the time of the order, the optional mold purge valve is factory-installed.



## CAUTION: Lifting

To avoid personal injury or damage to the RQT Premium, lift the unit using a fork-lift or hoist with straps that have been positioned at the center of gravity.

If using straps, be sure to use a spreader bar or equivalent so the top sheet metal of the RQT Premium isn't inadvertently pinched due to the lifting action.



- 1 Carefully remove the RQT Premium** and components from their shipping containers.
- 2 Remove all packing material**, protective paper, tape and plastic. Compare contents to the shipping papers to ensure that you have all the parts.
- 3 Carefully inspect all components** to make sure no damage occurred during shipping. Check all wire terminal connections, bolts, and any other electrical connections, which may have loosened during shipping.
- 4 Record serial numbers and specifications** in the blanks provided on the back of the User Guide's title page. This information will be helpful if you ever need service or parts.
- 5 You are now ready to begin installation.** *See Installation Section entitled, Preparing for Installation.*



**NOTE:** If the temperature control unit is stored prior to installation, it is important to protect it from damage. Blow out any water from the unit to protect it from damage from freezing. Cover the equipment to keep dirt and debris from accumulating on it. Units should not be stored in areas warmer than 145°F {63°C}.

\* The Flowmeter option does not come fully assembled.

# Preparing for Installation

The RQT Premium is easy to install, if you plan the location and prepare the area properly.

**⚠ WARNING: Improper installation, operation, or servicing may result in equipment damage or personal injury.**

This equipment should only be installed, adjusted, and serviced by qualified technical personnel who are familiar with the construction, operation, and potential hazards of this type of machine.

All wiring, disconnects, and fuses should be installed by qualified electrical technicians in accordance with electrical codes in your region. Always maintain a safe ground. Do not operate the equipment at power levels other than what is specified on the machine serial tag and data plate.

**1 Position the RQT Premium as close to the process machine as possible.**

**2 Make sure the installation area provides:**

- A three-phase power source supplying the sufficient current for your RQT Premium model.** Check the serial tag on the unit for required voltage, phase, frequency, and full load amps. Check the electrical prints for the disconnect fuse size and minimum wire connection size. All wiring should be completed by qualified personnel and should comply with your region's electrical codes.
- Compressed, dry air (<100 psi)** if your RQT Premium is equipped with the Mold Purge option.
- A clean, well-ventilated environment.** The room temperature should not exceed 104°F {40°C} with 95% non-condensing humidity and should not fall below 32°F {0°C}.
- Minimum clearance for safe operation and maintenance.** The diagram at the right shows minimum clearance for operation. You also need enough clearance in rear for water hookups. For maintenance, you should move the RQT Premium to provide at least 36 inches {91 cm} on any side of the RQT Premium. Additionally, your required electrical codes may require a larger service area in front of the electrical panel.

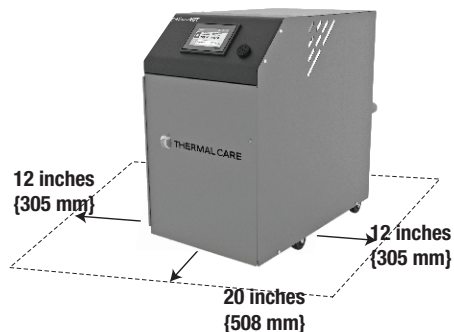
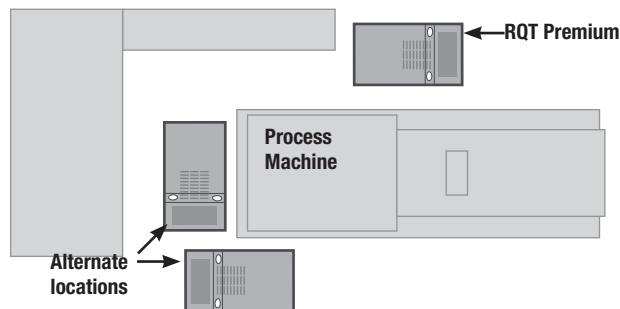

## Preparing for Installation (Continued)

Pump HP	Max Cooling (PSI)
3/4	95
1	90
2	90
3	85
5	75
7.5	65
10	50

(Assumes process hoses and process plumbing is rated to 150 psi.)

 **NOTE:** If your cooling water pressure exceeds the cooling water pressure chart referenced previously, install a pressure-regulating valve before the cooling inlet.

- A source of water for cooling.** City, tower or chiller water may be used, as long as the supply pressure is at least 30 PSI\*. Refer to max cooling water pressure chart shown to the left.
- A location to mount an external three-phase, fused, and grounded electrical disconnect.**
- Lockable isolation devices for all utilities,** including electrical disconnect, cooling water line valves, and compressed air supply disconnect and bleed-off.

\*Dynamic Max Setpoint allows for operation significantly below 30 PSI with certain combinations of pump HP and heater kW. This feature will automatically adjust maximum temperature setpoint based off of supplied pressure.

Check to make sure all piping connections are secure and that all lines are suitable for water or the coolant in the system at the maximum setpoint temperature and cumulative pressure rating of the maximum pump pressure plus the cooling water supply pressure, or the nameplate rating of the pressure relief valve, whichever is greater.

Make sure that the cooling source is the appropriate temperature and pressure for your application. In most cases, the cooling source is between 40°F {4°C} and 85°F {29°C}. For most applications, the design cooling source supply pressure is between 30 psi and 50 psi. Units with the 300°F operating range option require an inlet cooling source pressure of at least 75 psi (at sea level), in order to be permitted to operate the unit all the way up to 300°F. The pressure relief valve is located on the “From Process” side of the pump, and will start to discharge if the pressure exceeds 135 psi. If this becomes an issue, install a pressure-regulating valve (available from our Parts Department) on the supply line to help regulate the pressure to ensure it does not exceed the pressure rating of the pressure relief valve. For further assistance in installing a pressure-regulating valve, please contact our Customer Service Department.

### System Fill Water Chemistry Requirements

The properties of water make it ideal for heat transfer applications. It is safe, non-flammable, non-poisonous, easy to handle, widely available, and inexpensive in most industrialized areas.

When using water as a heat transfer fluid it is important to keep it within certain chemistry limits to avoid unwanted side effects. Water is a “universal solvent” because it can dissolve many solid substances and absorb gases. As a result, water can cause the corrosion of metals used in a cooling system. Additionally, dissolved minerals naturally present in tap water will precipitate out onto the system plumbing at elevated fluid temperatures, forming scale. The life giving properties of water can also encourage biological growth that can foul heat transfer surfaces.



# Preparing for Installation (Continued)

## Fill Water Chemistry

To avoid the unwanted side effects associated with water cooling, proper chemical treatment and preventive maintenance is required for continuous plant productivity.

### Unwanted Side Effects of Improper Water Quality

- Corrosion
- Scale
- Fouling
- Biological Contamination

### Cooling Water Chemistry Properties

- Electrical Conductivity
- pH
- Alkalinity
- Total Hardness
- Dissolved gases

The complex nature of water chemistry requires a specialist to evaluate and implement appropriate sensing, measurement and treatment needed for satisfactory performance and life. The recommendations of the specialist may include filtration, monitoring, treatment and control devices. With the ever-changing regulations on water usage and treatment chemicals, the information is usually up-to-date when a specialist in the industry is involved. The table below shows the list of water characteristics and quality limitations.

### Fill Water Chemistry Requirements

Water Characteristic	Quality Limitation
Alkalinity (HCO <sub>3</sub> <sup>-</sup> )	70-300 ppm
Aluminum (Al)	Less than 0.2 ppm
Ammonium (NH <sub>3</sub> )	Less than 2 ppm
Chlorides (Cl <sup>-</sup> )	Less than 300 ppm
Electrical Conductivity	10-500µS/cm
Free (aggressive) Carbon Dioxide (CO <sub>2</sub> ) <sup>†</sup>	Less than 5 ppm
Free Chlorine(Cl <sub>2</sub> )	Less than 1 PPM
HCO <sub>3</sub> <sup>-</sup> /SO <sub>4</sub> <sup>2-</sup>	Greater than 1.0
Hydrogen Sulfide (H <sub>2</sub> S)	Less than 0.05 ppm
Iron (Fe)	Less than 0.2 ppm
Manganese (Mn)	Less than 0.1 ppm
Nitrate (NO <sub>3</sub> )	Less than 100 ppm
pH	7.5-9.0
Sulfate (SO <sub>4</sub> <sup>2-</sup> )	Less than 70 ppm
Total Hardness (dH) <sup>k</sup>	4.0-8.5

<sup>†</sup> Dissolved carbon dioxide calculation is from the pH and total alkalinity values shown below or measured on the site using a test kit. Dissolved Carbon Dioxide, PPM = TA x 2<sup>[(6.3-pH)/0.3]</sup> where TA = Total Alkalinity, PPM as CaCO<sub>3</sub>

# Preparing for Installation (Continued)

## Recommend Glycol Solutions

Chilled Water Temperature	Percent Glycol By Volume
50°F (10°C)	Not required
45°F (7.2°C)	5 %
40°F (4.4°C)	10 %
35°F (1.7°C)	15 %
30°F (-1.1°C)	20 %
25°F (-3.9°C)	25 %
20°F (-6.7°C)	30 %



**CAUTION:** When your application requires the use of glycol, use industrial grade glycol specifically designed for heat transfer systems and equipment. Never use glycol designed for automotive applications. Automotive glycols typically have additives engineered to benefit the materials and conditions found in an automotive engine; however, these additives can gel and foul heat exchange surfaces and result in loss of performance or even failure of the chiller. In addition, these additives can react with the materials of the pump shaft seals resulting in leaks or premature pump failures.



**WARNING:** Ethylene Glycol is flammable at higher temperatures in a vapor state. Carefully handle this material and keep away from open flames or other possible ignition sources.



### 3 Install plumbing for process and cooling lines.

You will need two 1½-inch NPT male fittings for the process inlet and outlet and two 1-inch NPT male fittings for the cooling inlet and outlet. Larger line sizes are acceptable as long as they are reduced at the RQT Premium connections. The use of line size isolation valves are recommended.

Contact Thermal Care for more information about recommendations for your product.

## Fluid Distribution Piping

Proper insulation of any cooling fluid system where the supply cooling fluid temperature is below the dew point is crucial to prevent condensation. In most cases this will apply to systems where the supply temperature is 55°F {13°C} or colder. The formation of condensation on water piping caused by the state change of the water from gas to liquid adds a substantial heat load and becomes an additional burden for the cooling system.

The importance of properly sized piping between the cooling system and the temperature control unit and the process cannot be overemphasized. See the ASHRAE Handbook or other suitable design guide for proper pipe sizing. In general, run full size piping out to the process and then reduce the pipe size to match the connections on the process equipment. One of the most common causes of unsatisfactory unit performance is poor piping system design. Avoid long lengths of hoses, quick disconnect fittings, and manifolds wherever possible as they offer high resistance to water flow. When manifolds are required, install them as close to the use point as possible. Provide flow-balancing valves at each machine to assure adequate water distribution in the entire system. We recommend shut-off valves at each machine to allow for isolation of the unit.

## Installation - Electrical

- ❑ All wiring must comply with local codes and the National Electric Code (NEC). Full Load Amperes (FLA) and other unit electrical data are on the unit nameplate.
- ❑ An electrical schematic ships with the unit. This contains details about suggested upstream disconnect and wiring sizing, both of which your electrician will find useful.
- ❑ A qualified individual should measure each leg of the main power supply voltage at the main power source. Voltage must be within the voltage utilization range given on the drawings included with the unit. If the measured voltage on any leg is not within the specified range, it must be corrected before operating the unit.
- ❑ Voltage imbalance must not exceed two percent. Excessive voltage imbalance between the phases of a three-phase system can cause motors to overheat and eventually fail. Voltage imbalance is determined using the following calculations:

$$\% \text{Imbalance} = (V_{\text{avg}} - V_x) \times 100 / V_{\text{avg}}$$

$$V_{\text{avg}} = (V1 + V2 + V3) / 3$$

$$V_x = \text{phase with greatest difference from } V_{\text{avg}}$$

For example, if the three measured voltages were 442, 460, and 454 volts, the average would be:

$$(442 + 460 + 454) / 3 = 452$$

The percentage of imbalance is then:

$$(452 - 442) \times 100 / 452 = 2.2 \%$$

This exceeds the maximum allowable of 2%.

- ❑ There is a terminal block, or electrical disconnect switch, for main power connection to the main power source. The main power source should be connected to the terminal block through an appropriate disconnect switch. There is a separate lug in the main control panel for grounding the unit.
- ❑ Check the electrical phase sequence at installation and prior to start-up. Operation of the unit with incorrect electrical phase sequencing will result in an electric power fault displayed on the screen.
- ❑ To guarantee correct phase rotation at initial startup, check the phasing with a phase sequence meter prior to applying power. The proper sequence should read “clockwise” or “ABC” or “L1, L2, L3” on the meter. If the meter reads “counter-clockwise” or “CBA” or “L3, L2, L1”, disconnect and lockout main electrical power and switch two line leads on the line power terminal blocks (or the unit mounted disconnect). Do not interchange any load leads that are from the unit contactors or the motor terminals.

# Connecting Process and Water Supply Lines Without Purge

## Tools for Installation:

- ❑ Pipe wrench large enough for a 2-inch pipe
- ❑ Premium quality Teflon thread sealant

 **NOTE:** Thermal Care recommends using a second wrench, sometimes referred to as a “back-up wrench,” to support the piping when making connections to the RQT Premium.

 **NOTE:** Thermal Care recommends that you install an external ball valve on the cooling water inlet of the RQT Premium. This valve is required when the purge valve option is installed.

The RQT Premium process inlets and outlets must be connected to the plumbing that will circulate the temperature-controlled water or fluid through the process. Cooling water inlets and outlets are connected to the cooling water supply.

- 1 Remove the shipping pipe plug** from the female connections on the back of the RQT Premium.
- 2 Install pipe to the rear of the RQT Premium.** Use male 1½-inch NPT piping for process connections and male 1-inch NPT piping for water connections. Pipe and pipe threads must be clean and new. Clean threads with solvent, removing all oil, grease and dirt. Allow the threads to dry before proceeding.
- 3 Coat the pipe threads with thread sealant.** Follow the sealant manufacturer’s directions.
- 4 Connect the male pipe to the appropriate female connection** on the back of the unit. Start by hand until the threads engage, then use a pipe wrench to tighten the connection only enough to prevent leaks. **Do not over-tighten!**

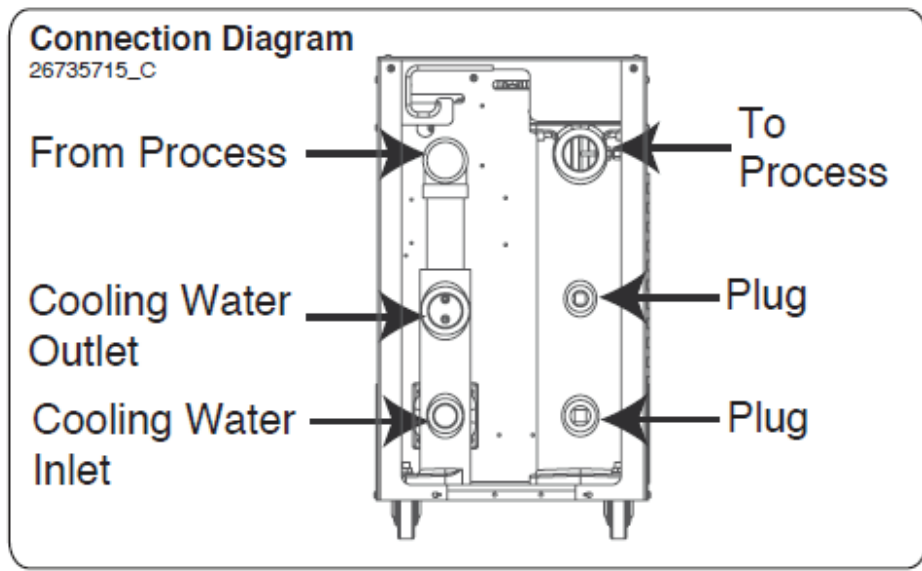

Sample Connection Diagram

Always refer to the connection diagram sticker on the back of your machine for proper connection locations.

Also beware that room-temperature water frequently contains a surprisingly large quantity of dissolved air within, and this air will separate from the water once heated to an elevated temperature. Additional provisions may have to be made to remove this air from the fluid loop, as it will inhibit heat transfer, and damage the pump and heater if it comes out of solution.

# Connecting Process and Water Supply Lines With Optional Mold Purge Valve Connections

A mold purge valve is available as an option. This valve quickly evacuates fluid from the process circuit, allowing faster disconnection of the temperature controller from molds and hoses.

If this option is ordered with the RQT Premium, purge control wiring and installation of the valve on the process line outlet of the unit is completed at the factory. You still must connect process and cooling water inlets and outlets, as well as supply non-lubricated compressed air.

**TIP:** Thermal Care recommends ordering the purge valve with the RQT Premium so that wiring and installation is completed at the factory. However, aftermarket addition of the purge valve is possible.

- 1 Remove the shipping pipe plug** from the female connections on the back of the RQT Premium.
- 2 Install an external lockable ball valve on the cooling water inlet of the RQT Premium.** This valve is required when a purge valve is used.
- 3 Install pipe on the rear of the RQT Premium.** Use male 1½-inch NPT piping for process connections and male 1-inch NPT piping for water connections. Pipe and pipe threads must be clean and new. Clean threads with solvent, removing all oil, grease and dirt. Allow the threads to dry before proceeding.
- 4 Coat the pipe threads with thread sealant.** Follow the sealant manufacturer’s directions.
- 5 Connect the male pipe to the appropriate female connection** on the back of the unit. Connect cooling water lines as indicated on the previous page. Connect process lines as indicated below. Start by hand until the threads engage, then use a pipe wrench to tighten the connection only enough to prevent leaks. **Do not over-tighten!**
- 6 Connect the purge valve to the compressed air supply.** The air pressure should not exceed 100 psi. Thermal Care strongly recommends a lockable air valve be installed in order to effectively lockout this energy source when performing equipment maintenance.

 **NOTE:** For information about how to add a purge valve to your RQT Premium if you did not order it equipped that way from the factory, contact Customer Service.

 **NOTE:** See “Using the Mold Purge Option” in the Operation section of this User Manual.



Sample Graphic  
This illustration may not reflect your configuration.

# Connecting the Main Power Source

## Tools Required

- Flashlight
- 1/8" Allen key
- Medium straight-blade screwdriver
- Phase rotation meter

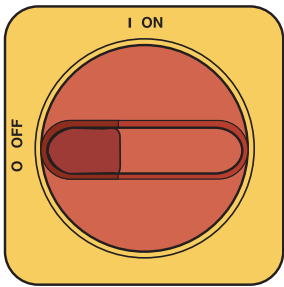

Optional  
Disconnect  
Switch

**IMPORTANT:** Always refer to the wiring diagrams that came with your temperature control unit before making electrical connections. The diagrams show the minimum size main power cable required for your unit, and the most accurate electrical component information.

**IMPORTANT:** Before initiating power to the unit:

- Check the system for leaks.
- Verify that the voltage, phase, frequency, amperage, disconnect fuse, and minimum wire size meet the specifications.
- Verify that resistance to ground on each phase is at least 1 mega ohm (use a multi-meter, not a megger for this measurement).

Before beginning, note the electrical specifications on the serial tag mounted to the side of the unit. The electrical connection must match these specifications with +/- 10% (+/- 15% for 400 V/50 Hz) maximum voltage variance and <2% imbalance. An improper power supply could damage the unit as well as seriously injure an operator. The electrical connection should run through a fused disconnect sized for the amperage noted on the electrical prints and conforming to all local and national codes, including Article 250 of the National Electric Code.



### **WARNING: Electrical Hazard**



Before performing maintenance or repairs on this product, disconnect and lock out electrical power sources to prevent injury from unexpected energization or start-up. A lockable device must be used to isolate this product from potentially hazardous electricity.



### **WARNING: Improper installation, operation, or servicing may result in equipment damage or personal injury.**



This equipment should only be installed, adjusted, and serviced by qualified technical personnel who are familiar with the construction, operation, and potential hazards of this type of machine.

All wiring, disconnects, and fuses should be installed by qualified electrical technicians in accordance with electrical codes in your region. Always maintain a safe ground. Do not operate the equipment at power levels other than what is specified on the machine serial tag and data plate.

- 1 Open the unit's electrical enclosure.** Removing the top panel using a 1/8" Allen key is required. The RQT Premium comes from the factory with a hole for 1/2 inch conduit. A knockout punch should be used if necessary to enlarge the hole for larger diameter conduits or cord grips.

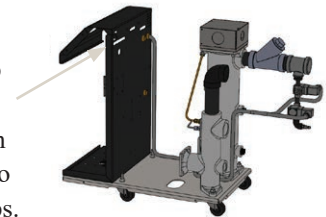

- 2 Install electrical conduit as desired, along with main power wires inside the conduit, or install the cord.** See electrical prints for recommended wire size. Knock out on the upper left hand side of the back of the electrical panel.

 **NOTE:** If using a flexible cord, secure the wire with a rubber compression fitting or strain relief.

- 3 Connect the power wires to the terminals indicated on the wiring diagram** that came with your machine. The RQT Premium comes pre-wired expecting clockwise (L1-L2-L3) phase rotation. Use a phase rotation meter to verify correct phasing. *See "Installation - Electrical" in this section of the User Manual for more information.*

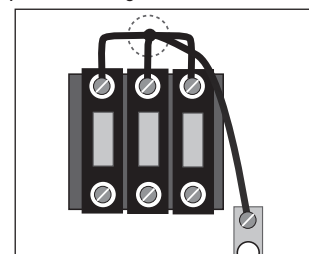

- 4 Check every terminal screw to make sure wires are secure.** Gently tug each wire. If a wire is loose, use a screwdriver or allen wrench to tighten the terminal.
- 5** Connect the ground wire to the grounding lug shown in the wiring diagram shipped with your unit.
- 6** Use the "J-Hook" at the back of the top panel to keep the power away from hot internal components.

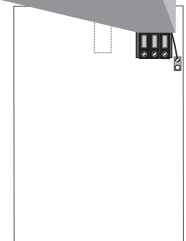

# Program Menu Accessibility

Access to certain program menu parameters are password protected to prevent unintended alteration to the program settings and parameters. The TCU is separated into 5 security level tiers, each with their own defined accessibility clearances. Security verification clearances are listed in order from most restrictive (guest) to most clearances (admin).

- 1 Guest (Default Password is “0000”)
- 2 Operator (Default Password is “3333”)
- 3 Setup (Default Password is “2222”)
- 4 Service (Default Password is “1111”)
- 5 Administrator (Default Password is “admin”)

Change Password Screen

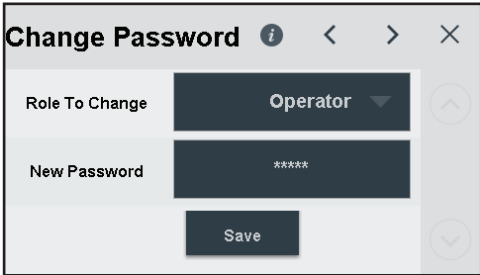

**NOTE:** Any box which is black is not editable, either due to your current user level, or the current operating mode of the machine.

Touch the box and a prompt will tell you what action must be taken to edit the value.

For the initial setup of the machine, it is easiest to login as “admin” to gain access to all user-adjustable settings.

From the factory, the default security level is “Operator” to always permit basic operation of the machine. To fully restrict the machine operation, you may change the Default Security Level to “Guest”, only permitting unauthenticated users to STOP the machine. Alternatively, you may elevate the Default Security Level to eliminate password entry if security is not a concern.

Change Auto Logout Screen

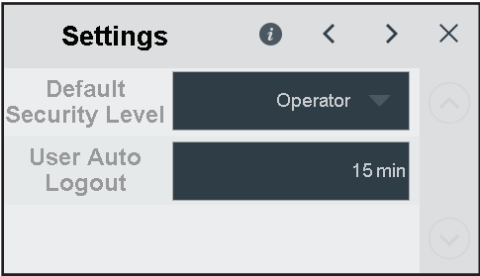

Note that some parameters can only be modified and defined by Thermal Care. If there are issues with configuration settings please contact Customer Service for assistance.

# Testing the Installation



**WARNING: Only qualified personnel should perform this procedure.**



Part of this test requires opening the unit while it is energized. Only qualified personnel who have been trained in the use of electrical testing devices and in avoiding the safety hazards involved in safely troubleshooting this type of equipment should perform this test procedure.

**1 Turn on the cooling water supply and check for leaks and proper water cooling pressure.** If any leaks appear, stop the test and fix the problem before continuing. The cooling water must be at least 10-30 psi (depending on your kW/HP configuration) or the unit will not function on standard 250°F {121°C} units less than 48kW. The Adaptive Max Setpoint feature will allow the unit to automatically adjust the maximum temperature setpoint based off of the supplied cooling water pressure.

**2 Apply power to the unit.** HMI touchscreen illuminates and boots up to indicate that the control has power. The control then displays the Home screen.

**3 Set the setpoint to 40°F by touching the screen area which displays the setpoint.** If prompted to login, see the previous section “Program Menu Accessibility” for default passwords.

**Press the RUN button.**

If everything is working correctly:

- The venting and/or pump status bar will pop up on the top of the controller.
- The unit initiates a 64-second venting sequence followed by 30 seconds of venting while the pump runs. The pump starts automatically when the venting sequence is partly complete.
- Normal operation begins. The heater turns on if the process temperature is below setpoint. The cooling valve is activated if the process temperature is above setpoint.



**NOTE:** If the low pressure warning pops up, verify that the cooling water supplied is connected properly and at the minimum required pressure.

**If everything tested correctly, proceed to the Initial Setup instructions on the next page.** If something did not work correctly, [refer to the Troubleshooting section of this User Guide.](#)

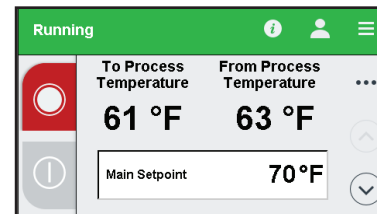
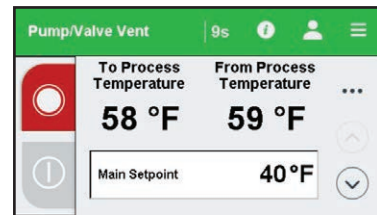
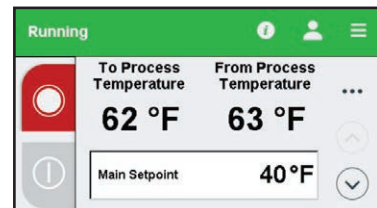
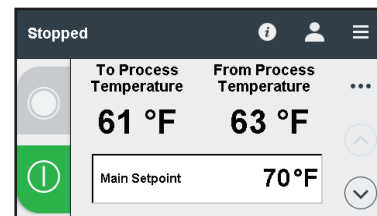

**NOTE:** An alarm banner will display on the screen if the TCU is incorrectly phased or if insufficient pressure is supplied.



**NOTE:** Pump motor rotation can be viewed at either the back of the motor, or at the exposed shaft where the motor meets the pump.



# Initial Setup

- Operating Mode
- Altitude, Fluid Type, and Units of Measure
- Setpoint
- Setting Process Value Source

**CAUTION:** The RQT Premium will not operate correctly if certain factory-set parameters are changed. Parameters should only be changed by qualified technical personnel who are familiar with the operation of this type of equipment. If the RQT Premium does not appear to be working correctly, verify the parameters against the list of factory settings.

Upon initial boot-up, you will be greeted with a load screen that indicates the TCU Tier, Pump Size, Heater Size, Heater Contactor Type, Voltage/Frequency, and Software Version

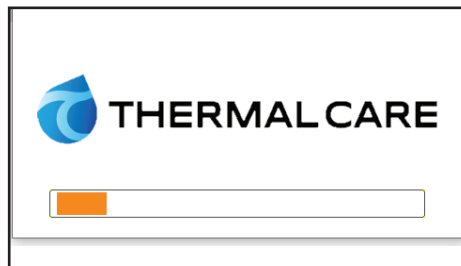

The Home screen is as shown here.

The contextual help can be accessed by tapping on the information icon  on the top of the controller.

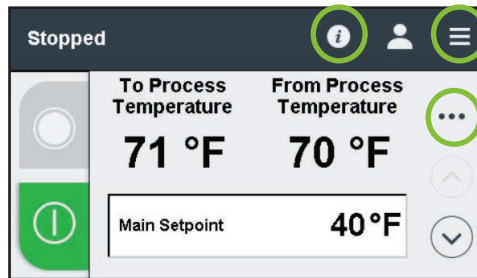

The “Main Menu” can be accessed by tapping on the “Main Menu” (hamburger menu) icon  on the top right corner of the controller.

The “More” menu can be accessed by tapping the three ... on the right side.

The “Main Menu” contains buttons that will take you to all of the functions on the machines.

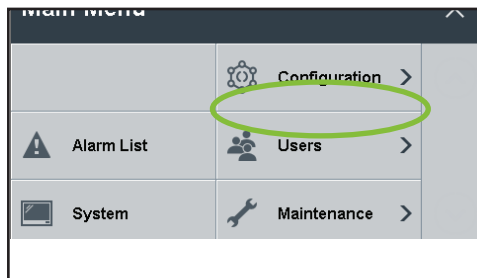

Machine configuration can be viewed by tapping on the “Configuration” menu selection shown.

**NOTE:** Certain machine configuration details/parameters can only be changed by Thermal Care Service or Factory.

The “More” menu contains the most commonly accessed machine functions.

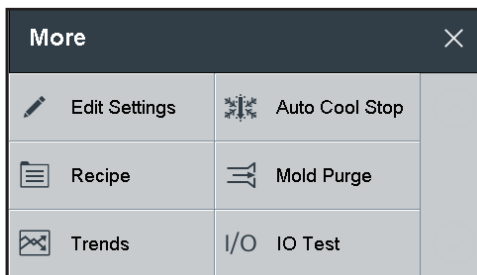

# Altitude, Fluid Type, and Units of Measure

 **NOTE:** You will need to log in as the appropriate level to access these settings/screens. See [Program Menu Accessibility section](#).

To select the desired altitude, fluid type, and units of measure for your system (°F vs °C), follow this procedure:

**1** Access the “More” settings window by tapping the three dots (...) on the Home screen.

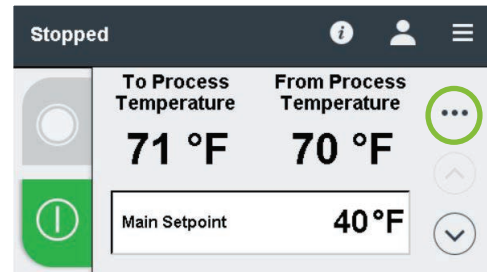

**2** Tap on the “Edit Settings” option.

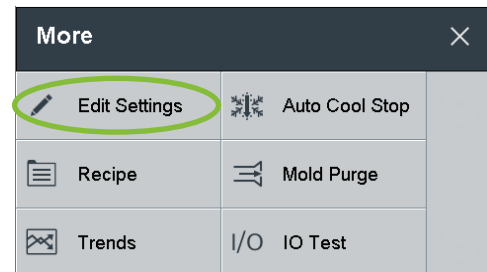

 **NOTE:** Any box which is black is not editable, either due to your current user level, or the current operating mode of the machine.

Touch the box and a prompt will tell you what action must be taken to edit the value.

For the initial setup of the machine, it is easiest to login as “admin” to gain access to all user-adjustable settings.

Scroll down by tapping the down arrow on the bottom right corner.

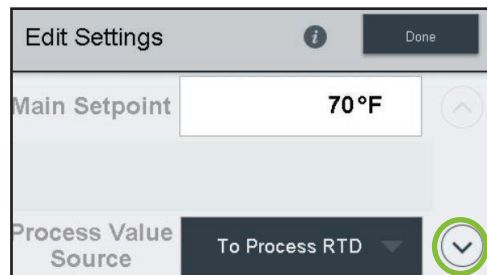

The altitude entered may be approximate and similarly with the fluid type.

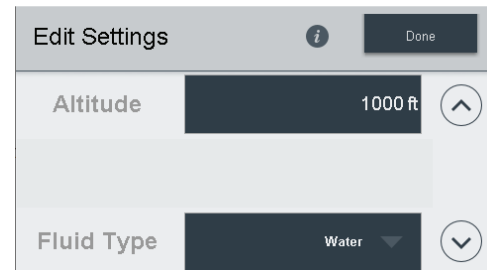

**3** After tapping the down arrow once more, units can be changed on the screen shown.

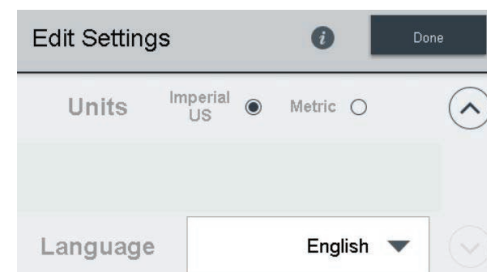

# Setpoint

To select the proper setpoint of the system, follow this procedure:

- 1 The temperature setpoint can be quickly adjusted by tapping on the “Main Setpoint” bar on the Home screen.

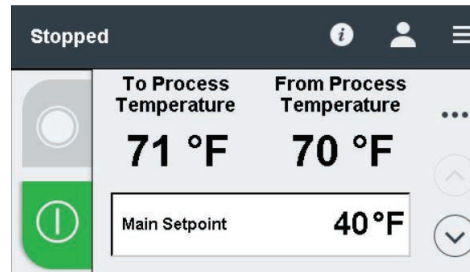

- 2 This screen will pop up and prompt you to input your desired temperature setpoint.

**Note:** From the factory the TCU will control the “To Process” or “Supply” fluid to the setpoint. However, this can be modified by following the procedure below.

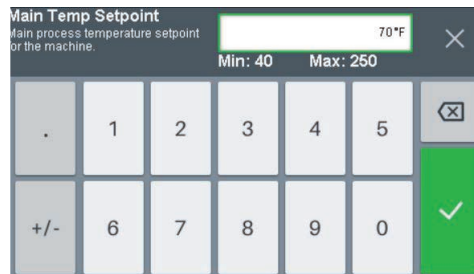

**NOTE:** Setpoint range can be expanded for your application based on process fluids used (Glycol). Maximum pressure setting may be dependent upon cooling water pressure.

# Setting Process Value Source

The TCU can be customized to control temperature at various RTD (resistive temperature detector) measurement points, such as a Remote Pt1000 RTD, To Process RTD, From Process RTD, or a calculated average of the To and From Process RTDs.

- 1 Tap on “Edit Settings”.

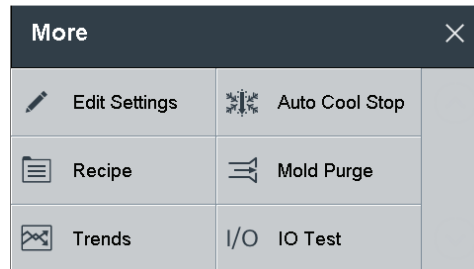

- 2 Tap on the drop down next to “Process Value Source” in order to change how the TCU controls temperature.

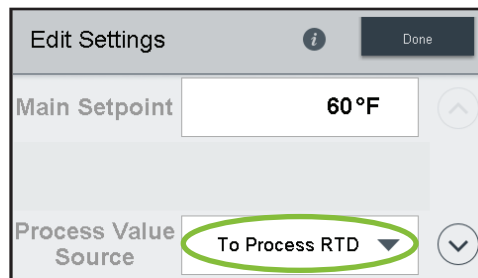

**NOTE:** The Remote RTD will only show on the menu if one is installed and connected to the RQT Premium as shown in the wiring diagrams.

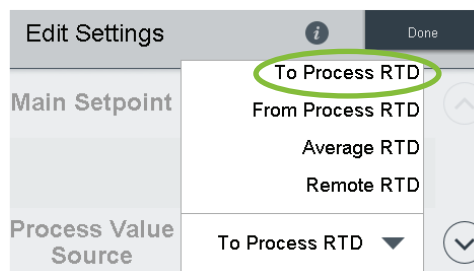

# Setting Up Your Controller

## Alarm Points

To select the desired alarm points for your system (low alarm and high alarm), follow this procedure:

**1** If running, stop the RQT Premium by going to the Home screen and pressing STOP.

**2** Enter the Alarms settings by following the screens below.

**3** Ensure that the unit is stopped by checking the banner status on the upper left corner of the controller. Access the “Main Menu” by tapping on the Main Menu (hamburger menu) icon on the upper right hand corner.

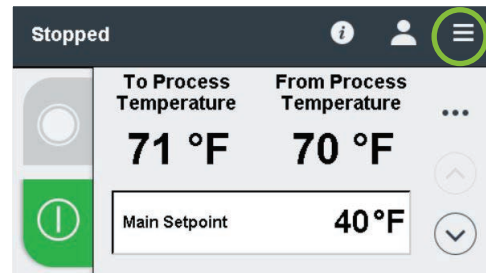

**4** Tap on the “Configuration” option shown.

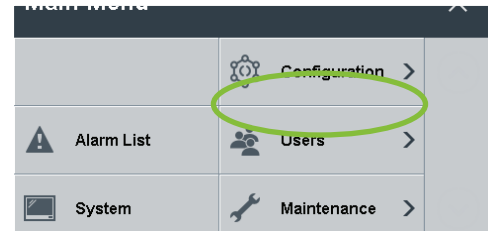

**5** Tap on the down arrow.

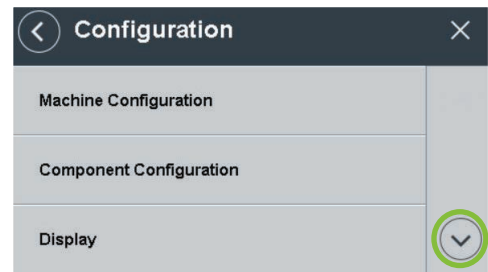

**6** Tap on “Alarms”.

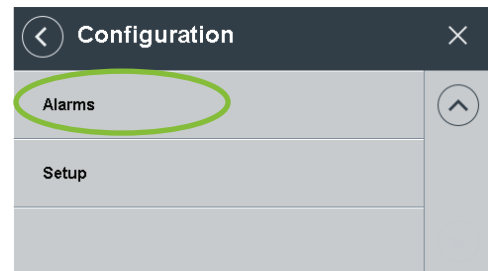

(Continued)

# Setting Up Your Controller (Continued)

**7** You may select how you want the TCU to act if the temperature deviates from the set temperature from the drop down shown. The high deviation limit indicates temperature deviation ABOVE the setpoint, whereas the low deviation limit indicates temperature deviation BELOW the setpoint.

If “Do Nothing” is selected for “Deviation Action”, all related parameters disappear.

**8** Alarm deviations indicate how long you want the system to tolerate a temperature excursion outside of the deviation window before alarming or warning. Warm-Up Delay specifies how long to suppress temperature deviation monitoring after machine startup. This time, in addition to High Dev Delay / Low Dev Delay, the Warm-Up Delay prevents false triggering of this alarm/warning during the initial machine warmup and/or temporary temperature excursions from setpoint.

**9** Alarm high and low temperature settings can be modified here. Further alarm limitation settings can be accessed by tapping on the down arrow.

**10** Factory high and low temp alarm settings. Further alarm limitation settings can be accessed by tapping on the down arrow.

**11** Alarm limits for the temperature readings within the electrical cabinet and max pressure within the system. Flow Alarms can be accessed by tapping on the RIGHT arrow on the top of the screen.

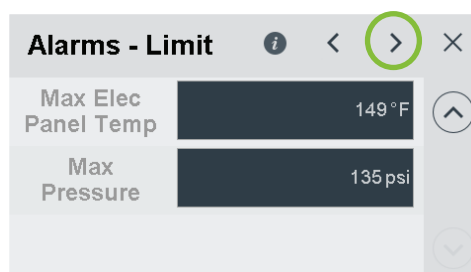
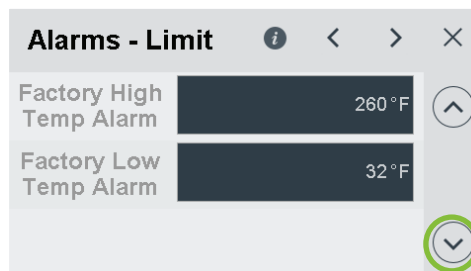
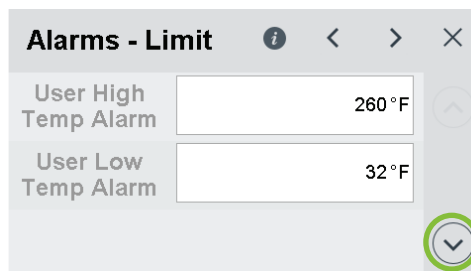
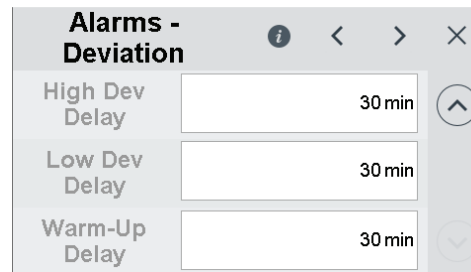
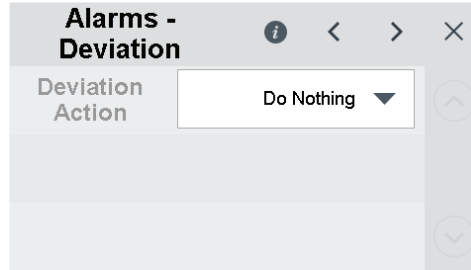
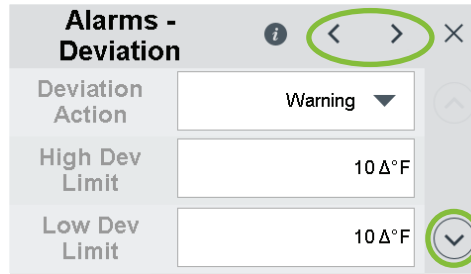

**NOTE:** Pressing the left/right arrows (< >) on the top of the screen allows you to move between subsections of the menus.

## Setting Up Your Controller (Continued)

- 12** If estimated flow is enabled without a flowmeter, it can still be alarmed.

Alarms - Est Flow	
Trip Action	Alarm ▼
Trip Threshold	38 gpm
Trip Delay	5 s

- 13** The screen will look slightly different based on if you have a flowswitch or a flowmeter installed.

Alarms - Flowswitch	
Trip Action	Alarm ▼
Trip Delay	5 s

Alarms - Flowmeter	
Trip Action	Alarm ▼
Trip Threshold	38 gpm
Trip Delay	5 s

### Flowmeter

Main Menu→Configuration→Machine Configuration→Flowmeter

Under Machine Configuration you can add your own flowswitch/flowmeter if you did not order one with the factory. Be sure to wire it according the wiring schematics. A flow-switch (NO or NC), pulse flowmeter (sourcing), analog flowmeter (0-10V), or analog flowmeter (4-20mA) are all supported, but the desired type must be selected from the configuration menu. If no flowmeter is configured “Estimated Flowrate” will be computed instead, if this feature is enabled from the factory.

 **NOTE:** Flowmeters are typically installed on the “To Process” side of the pump to monitor flow to the mold.

 **NOTE:** Depending on your selection of Flowmeter type, the screen sequence will vary.

**Estimated Flow Rate** - Reads differential pressure across the pump with pressure transducers and relates it to the pump curve to provide an estimated flow value.

Flowmeter	
Type	None ▼
Estimated Flowrate	✓

# Setting Up Your Controller (Continued)

**Limit Switch** - Detects if there is flow at a predetermined setpoint followed by a designated action. Be sure to configure what kind of contact state is considered to be an alarm.

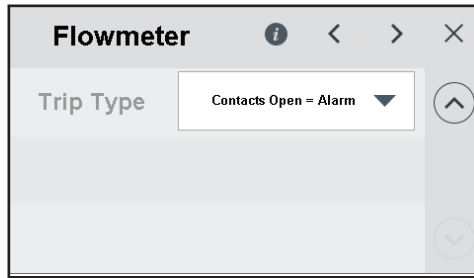

**Pulse Flowmeter** - Pulse rate flowmeters (most common is turbine flowmeter) measure a mechanical motion and convert it into an electrical pulse that can be read digitally.

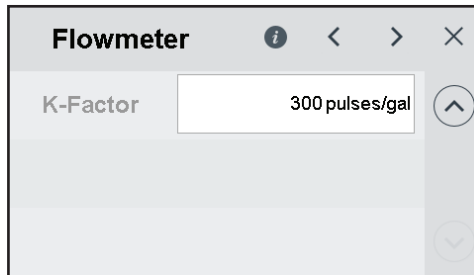

**Analog 0 - 10VDC** - Provides a flow reading by detecting voltage from 0V to 10V relative to the full-scale output of the flowmeter, ie., at 0V flowmeter reads 0 gpm whereas 10V reads full-scale output of flowmeter.

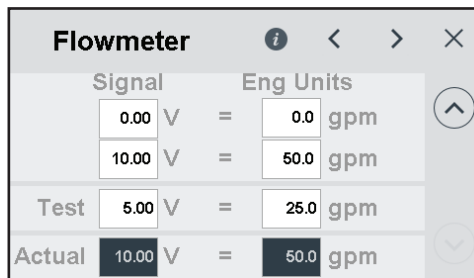

**Analog 4-20mA** - Provides a flow reading by detecting current from 4mA to 20mA relative to the full-scale output of the flowmeter, ie., at 4mA flowmeter reads 0 gpm whereas 20mA reads full-scale output on flowmeter.

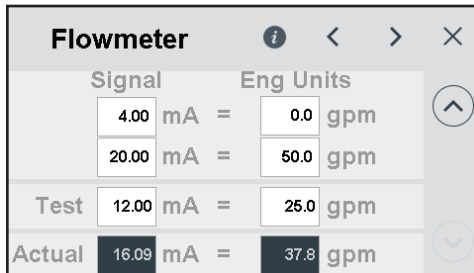

# Setting Up Your Controller (Continued)

## Calibrations

Calibrations may be applied to any analog device. These include:

- RTD's zero offset.
- K-Factor for Pulse Flowmeters
- Span and Zero offset for both 0-10V and 4-20mA Analog Flowmeters
- Analog Process Retransmit

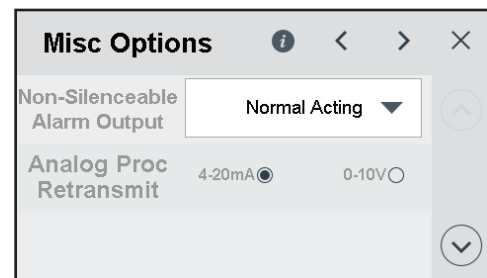
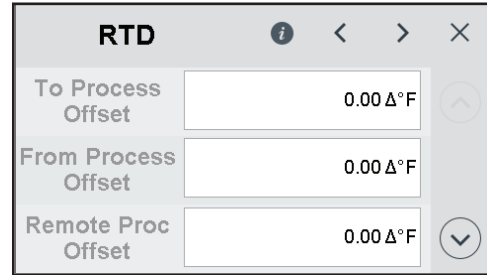

If Analog Process Retransmit is set to 4-20mA:

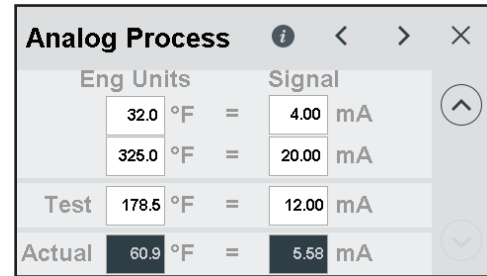

If Analog Process Retransmit is set to 0-10V:

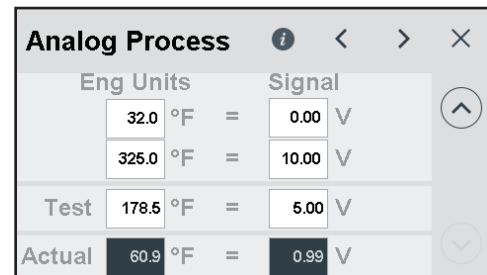

Some calibrations are factory set and cannot be modified by the user. If you have a need to change these, please contact Thermal Care Customer Service.

- Pressure Sensors
- Modulating Valve Signal
- 2-wire RTD offset

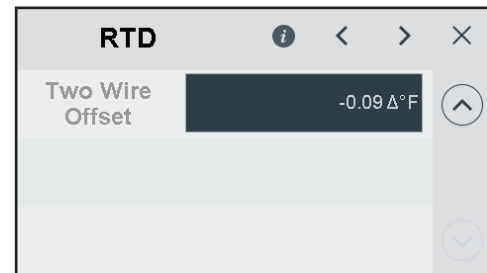



# Setting Up Your Controller (Continued)

## Display

To access Display Settings from the Home screen, tap on the hamburger icon to access the Main Menu.

Main Menu → Configuration → Display

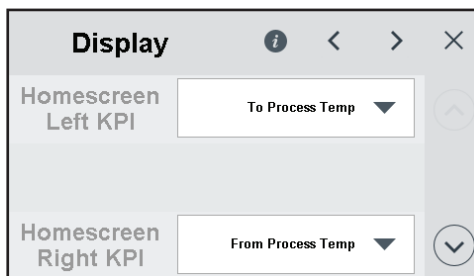

In the Display section, you can customize the KPIs (Key Performance Indicators) that are shown on the Home screen, as well as the screensaver.

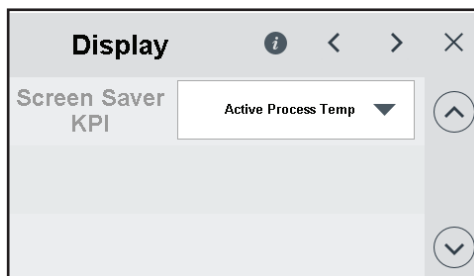

It is recommended that you leave the smoothing parameters set to their factory defaults unless you find there is a specific need to change them

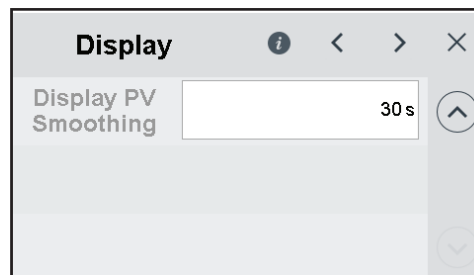

## Applications

This menu should have already been setup correctly during initial startup, but double-checking its settings is always wise.

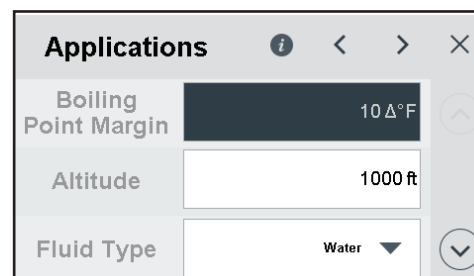

**Boiling Point Margin** - margin between measured and calculated theoretical boiling point to account for measurement errors, system hot spots, and safety factor.

**Altitude** (approximate) - elevation level unit is operating in.

**Fluid Type** (approximate) - fluid media used in the process lines.

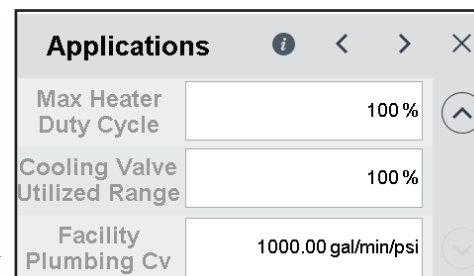

**Max Heater Duty Cycle** - The maximum amount of heater output when the algorithm is calling for 100% heat. Useful in cases where limiting heat output or electrical current is desired.

**Cooling Valve Utilized Range** - The maximum amount of cooling valve open position when the algorithm is calling for 100% cooling.

**Facility Plumbing Cv** - The pressure drop present in the cooling fluid utility plumbing that would cause a pressure drop when the machine is consuming cooling water.

# Setting Up Your Controller (Continued)

## Hot Pressure Relief

Determines how the machine will respond to expanding water in the process loop as it heats up. It is recommended not to change these settings unless there is a reason to do so.

Hot Pressure Relief is a feature designed to limit the discharge of the pressure relief valve by anticipating a pressure spike and opening the cooling valve to control system pressure. This feature primarily addresses pressure relief valve discharging frequency when a check valve is installed on the TCU.

Settings for Hot Pressure Relief feature can be accessed from the Home screen by tapping on the hamburger icon to access the Main Menu.

Main Menu→Configuration→Hot Pressure Relief

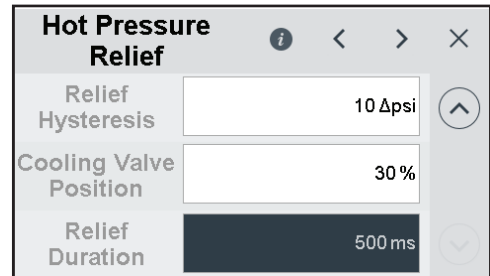
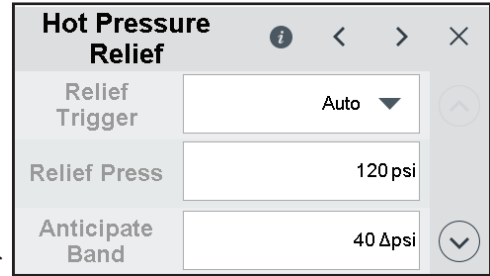

## Set Up Settings

It is recommended to run through the Setup Settings to tailor any parameters to your process before starting. The Setup Settings can be accessed from the Home screen by tapping on the hamburger icon to access the Main Menu→Configuration→Scroll Down by Tapping the Down arrow→Setup. This should take you to the Setup - Settings screen shown to the right.

Main and Alternate Setpoint temperatures can be modified here as well as the setpoint source can be chosen from the dropdown.

The process value source that is used to determine the temperature the TCU will control against. The process value smoothing determines how much smoothing to apply to the process value before it is sent back to the loop control.

If Mold Purge is installed, the following related parameters will be shown.

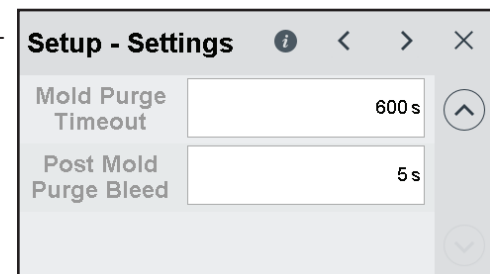
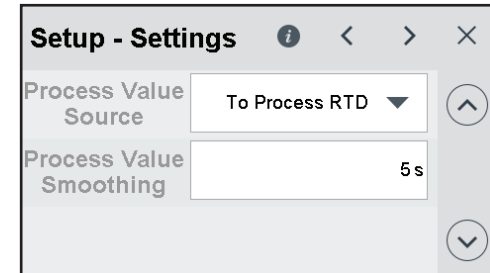
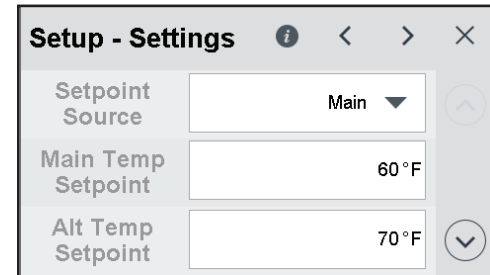

# Setting Up Your Controller (Continued)

If Auto Restart is off:

**Auto Restart** - When enabled, Auto Restart will restart the unit automatically after a loss of power event, but only if the unit was running when power was lost.

**Brownout Monitor** - if turned on, will notify the user with an alarm if low voltage or power was lost while in operation.

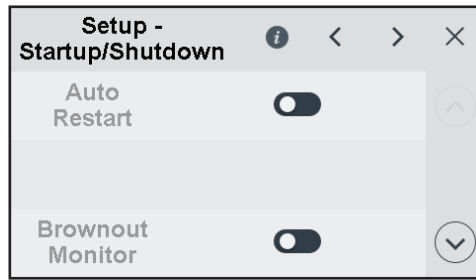

If Auto Restart is on, you can select how long to wait after power-up to execute a RUN command. This can be particularly useful if your facility experiences frequent power interruptions and you want to make extra certain the power has returned permanently before restarting.

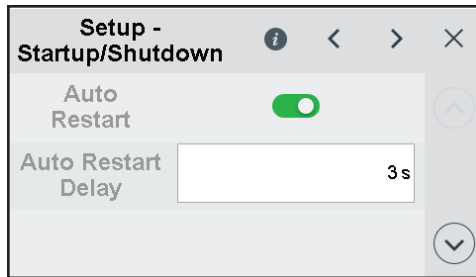

**Auto Cool Stop Temp** - When Auto Cool Stop is engaged, this is the temperature the TCU will stop cooling at.

**Auto Cool Stop Max Time** - the maximum amount of time that Auto Cool Stop will be enabled.

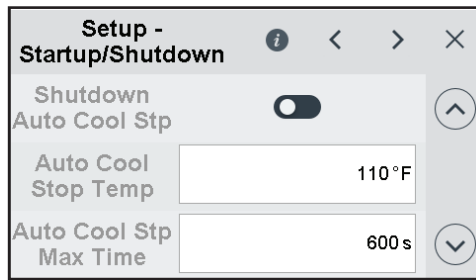

**Remote Start** - When enabled will allow the TCU to start remotely without having to be present at the machine.

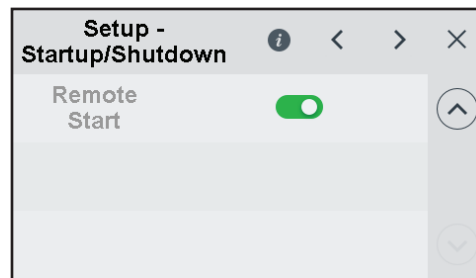

**Valve Vent** - Duration of the vent cycle with only the cooling valve open (no pump).

**Valve/Pump Vent** - Duration of the vent cycle with both the cooling valve open and the pump running.

**Vent Bypass Temp** - Process temperature above which the vent cycle will be skipped.

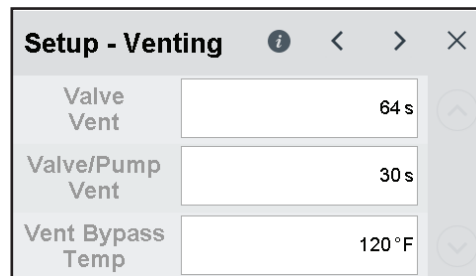

## Setting Up Your Controller (Continued)

**Ride Through** - How long to ignore a low- or no-pressure situation, which can be handy if your facility experiences sudden, intermittent pressure drops which recover quickly.

**Recovery Delay** - How long to wait before restarting after machine operation is paused due to a low pressure condition.

**Event Count** - How many low pressure pause events can occur before an alarm is issued.

**Event Count Time** - The time period during which low pressure events are tracked for alarming.

**Low Pressure Timeout** - How long the unit can remain in a low pressure pause state (Non-Ramp/Soak Mode) and still automatically restart if pressure returns.

**Ramp/Soak LP Time Out** - How long the unit can remain in a low pressure pause state during Ramp/Soak execution and still automatically restart if pressure returns.

### Ramp Soak

To access Ramp Soak feature from the Home screen, tap on the hamburger icon to access the Main Menu.

Main Menu → Configuration → Machine configuration → Setup → Push right arrow until reaching “Ramp Soak”.

Ramp soak is a programmable feature which allows a preset set of instructions to be defined by the user to control temperature. Triggers can be defined by various parameters such as setpoint or time. For example, with Ramp Soak enabled, the unit can ramp up to reach a defined setpoint, with a timed delay before activating a trigger which steps the function into the next step.

Ramp/Soak repeats identically for steps 2 through 5.

**Setup - Low Pressure**

Ride Through	1000 ms
Recovery Delay	1500 ms

**Setup - Low Pressure**

Event Count	3
Event Count Time	15 min

**Setup - Low Pressure**

Low Pressure Timeout	10 min
Ramp/Soak LP Timeout	10 s

**Ramp Soak**

Step	Step 1
Setpoint	71 °F
Trigger For Next Step	Time

**Ramp Soak**

Next Action	Go To Step
Step/Delay Duration	60 s
Next Step	Step 2

**Ramp Soak**

Time Rate Limit	100 s
Temperature Rate Limit	0 °F/hr
Limit Starts	Previous Step's Setpoint

# Setting Up Your Controller (Continued)

## Control Loop

Various PID tuning parameters are shown here and can be customized as desired. See “PID Parameters” in Appendix B.

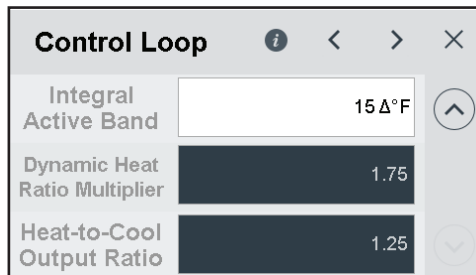
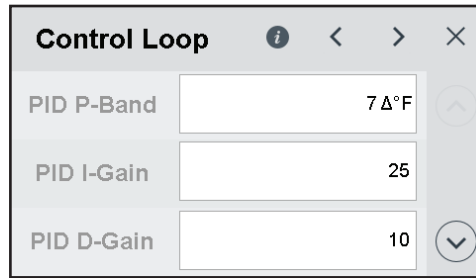

## Adaptive Max Setpoint

Adaptive max setpoint is a dynamic feature that will warn the user if the incoming supply pressure is insufficient to achieve the defined setpoint. A prompt will show a recommended temperature based off of the cooling water in supply pressure that the TCU senses.

The action that will be taken by the machine if a low pressure event occurs can also be customized by the user.

- **Pause** will resume machine operation automatically once pressure returns.
- **Lowering** operation will automatically reduce the setpoint if the pressure falls and cannot support such a high setpoint.
- **Tracking** operation will automatically lower the setpoint if pressure is lost, but will also raise the setpoint back up to the last user-entered value if pressure returns.
- **Max Tracking** will dynamically link the setpoint to the maximum temperature supported by the current system pressure.

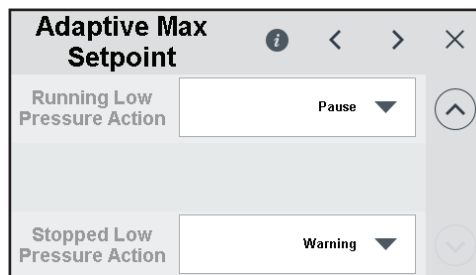
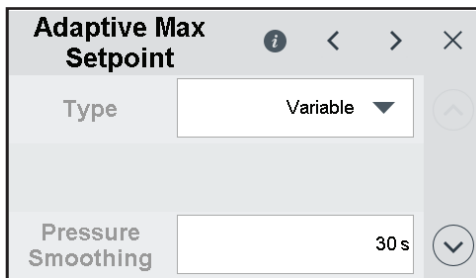

Settings for Adaptive Max Setpoint feature can be accessed from the Home screen by tapping on the hamburger icon to access the Main Menu.

Main Menu → Configuration → Machine configuration → Setup → Push right arrow until reaching “Adaptive Max Setpoint”.

# Setting Up Your Controller (Continued)

## Panel Settings

To access Panel Settings from the Home screen, tap on the hamburger icon to access the Main Menu. From the Main Menu, tap on the System Icon. Panel Settings allow access to language settings, Default Security level settings, Screen Save/Backlight Timeout, Serial Number, Firmware Version, and Software Version.

**User Auto Logout** - Defines how long before the logged in user's state is returned to the Default Security Level.

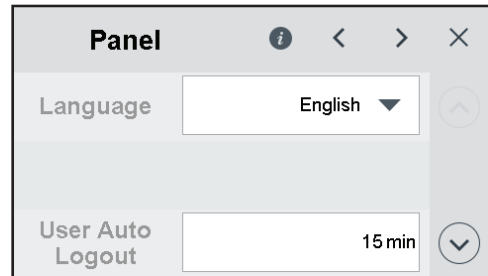

**Screen Saver Timeout** - How many seconds of inactivity before the screensaver is activated.

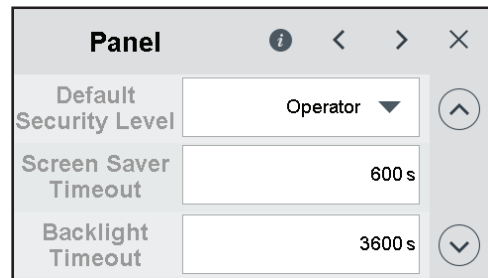

**Backlight Timeout** - How many seconds of inactivity before the screen backlight is dimmed.

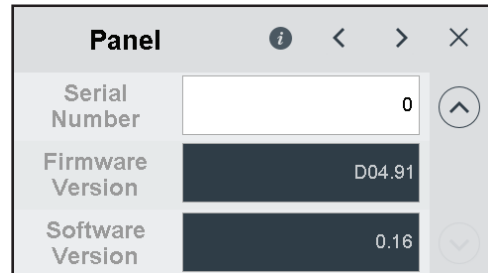

## Date and Time

Used to set the time, date, and timezone. This is important for accurate reporting of warnings and alarms in the alarm log.

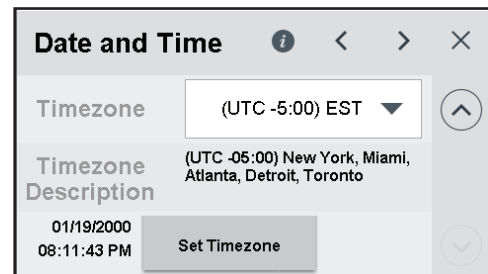
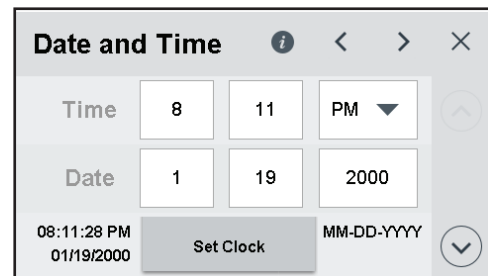

# Setting Up Your Controller (Continued)

## Recipes

To access Recipes from the Home screen, tap on the (...) icon to access the Additional Settings screen where the Recipes feature is located.

Recipes allow users to create, save, and store recipes for specific materials or applications to control the process main setpoint as well as certain parameters and preferences.

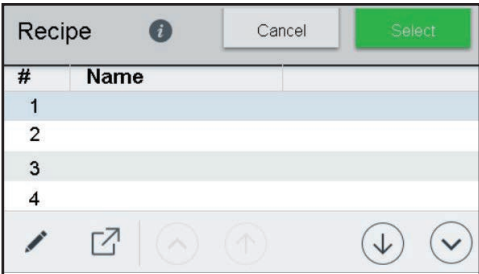

## Trending

To access Trending from the Home screen, tap on the (...) icon to access the Additional Settings screen where the Trends feature is located. Trending tracking parameters can be modified by tapping on the left or right arrows on top of the trending graph screen.

Trending information provides historical performance data tracking variables such as To/From Process Temperatures, Average Temperature, Heating and Cooling Percentages, and Temperature accuracy.

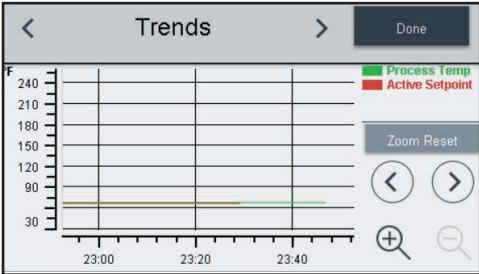

# Setting Up Your Controller (Continued)

## System Maintenance

In the event that a system reset to factory settings is required, there are several options provided to reset the TCU parameters.

To access System Maintenance from the Home screen, tap on the hamburger icon to access the Main Menu.

Main Menu→Maintenance→System Maintenance.

Note that these settings are only available to user security levels Setup, Service, or Admin.

### Default System Parameters

This will reset sequencing behaviors, units, networking, loop control, ramp soak parameters, and display settings.

### Default User Parameters

This will reset machine sequencing behaviors such as vent cycle times, low pressure even time outs and ramp soak parameters.

### Default Health Parameters

This will reset tracking information regarding heater contactors, valve, and pump runtime.

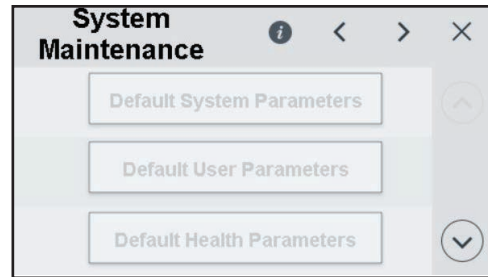

### Default Recipe

Resets Recipes to default settings.

### Clean Screen

Disables the touchscreen for a period of time so that the user/operator may wipe off the HMI screen.

### Calibrate Touch

Prompts the user through a series of calibrating exercises to calibrate the accuracy of the touchscreen.

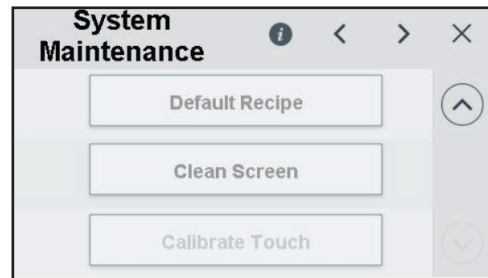



# Operation

---

The RQT Premium Control .....	4-2
Start-up.....	4-4
Starting the RQT Premium.....	4-5
Stopping the RQT Premium .....	4-6
Program Menu Accessibility.....	4-7
SPI Communications (Optional).....	4-8
SPI Option Parameters .....	4-10
Normal Operation .....	4-10
Operation of the Screen Saver.....	4-10
Seal Saver/Auto Cool Stop Sequence Initiation.....	4-12
Using the Mold Purge Option .....	4-12
System Maintenance .....	4-14

# The RQT Control

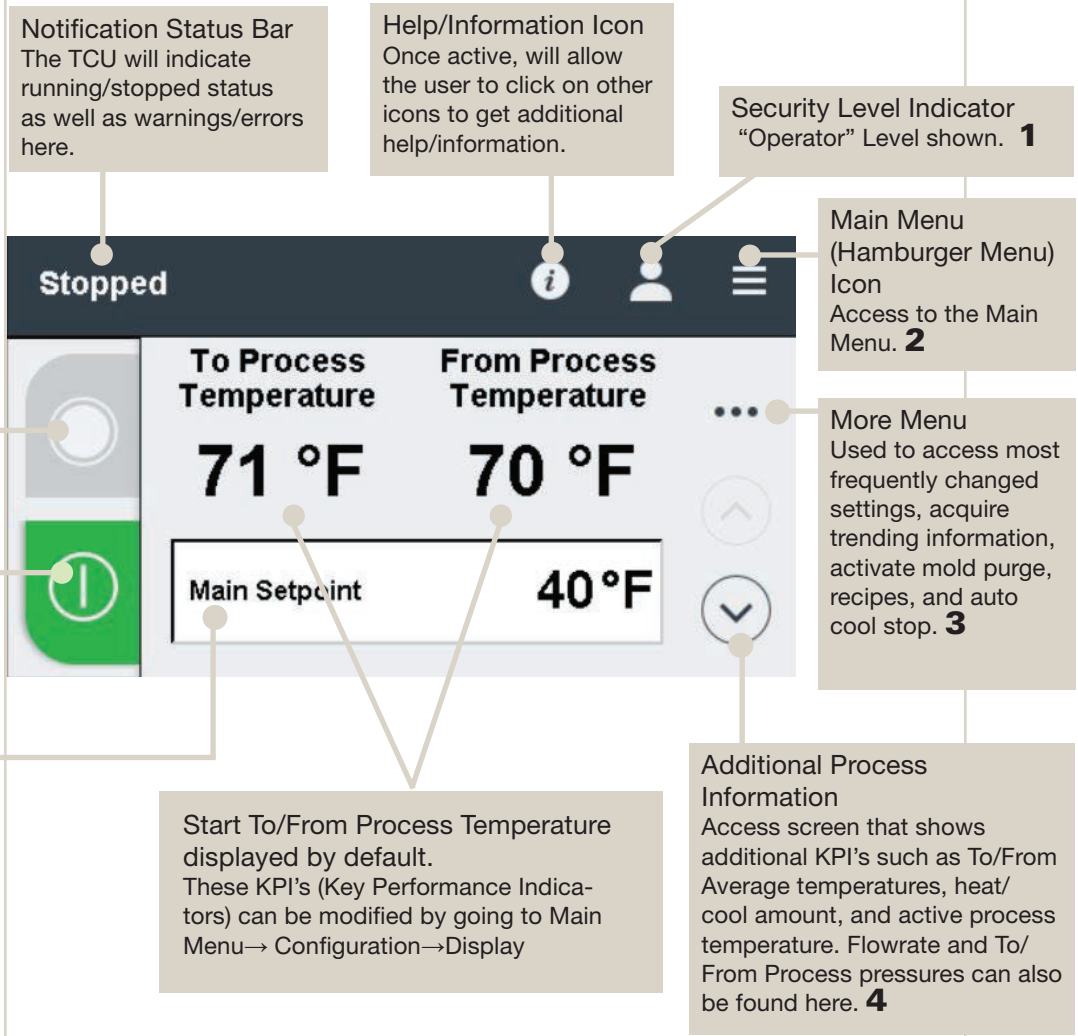

**1** Tapping on the Security Level Indicator Icon will open the screen below. By tapping on "Switch User", a new screen will appear requesting a passcode to be entered. Reference "Program Menu Accessibility" in this section, for user level security clearance passcodes

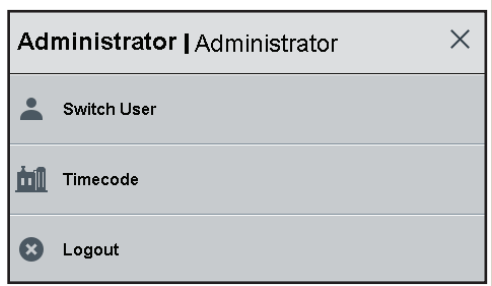

# The RQT Premium Control (Continued)

- 2 Tapping on the Main Menu (Hamburger Menu) Icon will bring up the Main Menu where you can access system settings, configurations, alarms, user, and maintenance menus.

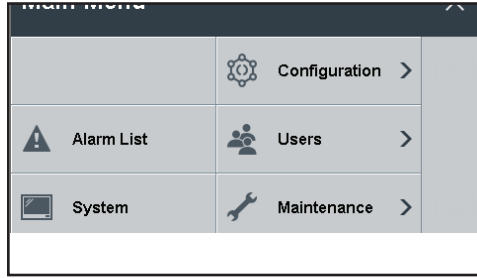

- 3 Tapping on the ... icon will bring up the More Menu with commonly used functions such as mold purge (if option was purchased), recipes, trending information and auto cool stop.

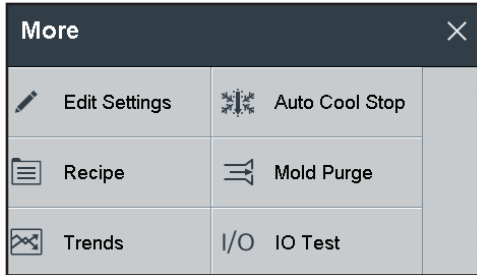

- 4 Tapping on the down arrow will pull up additional KPI's that shows process pressure vales, heating and cooling amounts, and other temperatures.

Additional KPIs may be shown based on installed options and settings.

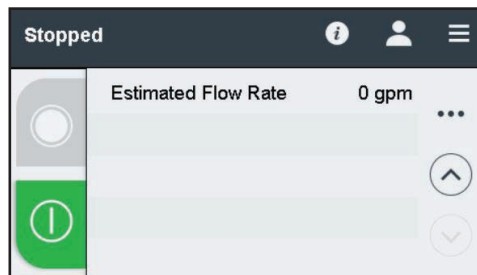
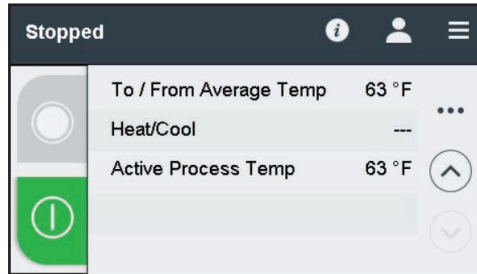
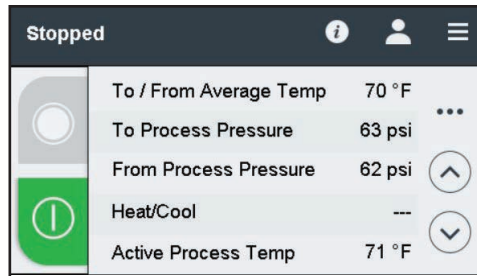

# Start-up

Every unit is factory set to deliver water in accordance with the standard operating specifications for that particular unit. Due to variables involved with different applications and different installations, minor adjustments may be required during the initial start-up to ensure proper operation. We recommend a qualified technician perform the start-up and that they follow the start-up procedure in sequence. The following serves as a checklist for the initial start-up and for subsequent start-ups if the unit is out of service for a prolonged time.



## **WARNING: Electrical hazard**



Before performing maintenance or repairs on this product, disconnect and lock out electrical power sources to prevent injury from unexpected energization or start-up. A lockable device must be used to isolate this product from potentially hazardous electricity.



## **WARNING:**



This equipment contains hot water or coolant under pressure. Accidental release of this hot fluid may result in steam formation and can cause personal injury and or property damage.



## **WARNING:**



This equipment may contain fan blades or other sharp edges. Make sure all fan guards and other protective shields are securely in place.



## **WARNING:**



The exposed surfaces of motors, heater tubes, and other fluid circuit components can be very hot and can cause burns if touched with unprotected hands.



**CAUTION:** Disconnect and lock out incoming power before installing, servicing, or maintaining the equipment. Connecting power to the main terminal block energizes the entire electric circuitry of the unit. A power supply provides 24 VDC control power. Electric power at the main disconnect should be shut off before opening access panels for repair or maintenance.



**CAUTION:** Wear eye protection when installing, maintaining, or repairing the equipment to protect against any sparks, debris, or fluid leaks.



**CAUTION:** Wear protective gloves when installing, maintaining, or repairing the equipment to protect against any sparks, debris, or fluid leaks.



**CAUTION:** To prevent improper pump performance due to reverse rotation, connect L1-L2-L3 in the A-B-C phase sequence.



**CAUTION:** Do not shut off To Process, From Process, Cooling Water In, or Cooling Water out valves while this equipment is operating. Equipment failure and/or serious injury could result.



**CAUTION:** Always keep the cover in place while operating this equipment. Internal surfaces may be extremely hot. Only qualified personnel should remove this cover.



**CAUTION:** Ground the unit properly in compliance with local and national codes.

# Starting the RQT Premium

Before starting the RQT Premium, verify that the system has been installed correctly for your application. See the *Installation section of this User Guide*.

- 1 Turn on the water supply to the RQT Premium.** The supply pressure must be at least 30 psi for most units. Check for leaks in the cooling water and process fluid lines before continuing.
- 2 Turn on main power to the RQT Premium.**
  - The controller display will illuminate to indicate the control has power.
- 3 Set the temperature setpoint to 40°F (4.4°C)** if the RQT Premium’s process lines were recently reconfigured, or if you suspect excessive air is in the process lines.
- 4 Set the setpoint to 40°F by touching the screen area which displays the setpoint.** If prompted to login, see the previous section “Program Menu Accessibility” for default passwords.

**Press the RUN button.** 

If everything is working correctly:

- The venting and/or pump status bar will pop up on the top of the controller.
- The unit initiates a 64-second venting sequence followed by 30 seconds of venting while the pump runs. The pump starts automatically when the venting sequence is partly complete.
- Normal operation begins. The heater turns on if the process temperature is below setpoint. The cooling valve is activated if the process temperature is above setpoint.

 **NOTE:** If the low pressure warning pops up, verify that the cooling water supplied is connected properly and the minimum required pressure.

- 5 Set the setpoint to the desired temperature,** by touching the setpoint box at the bottom of the Home screen and modifying it accordingly.
- 6 Silence the optional audible alarm.** If an alarm/warning is triggered, tap on the banner for additional information regarding the alarm/warning status. A (silence alarm symbol) can be pressed on the screen to silence the audible alarm.

*Refer to the Troubleshooting section for more information.*

 **NOTE:** If minimum 30 psi cooling water supply pressure is not achieved, the TCU will automatically adjust the maximum temperature based off of the provided supply pressure.

 **NOTE:** If the coolant pressure warning banner pops up, verify that the cooling water supply is connected properly and that the water pressure is at least 30 PSI or greater. Significantly higher pressures will be required to support high setpoints on 300°F {149°C} units except for 48 kw or 300°F {149°C} units.

 **NOTE:** Both venting stages will be skipped if the process temperature is above the vent bypass temperature, and the RQT Premium will subsequently start the pump immediately in the “RUNNING” state.

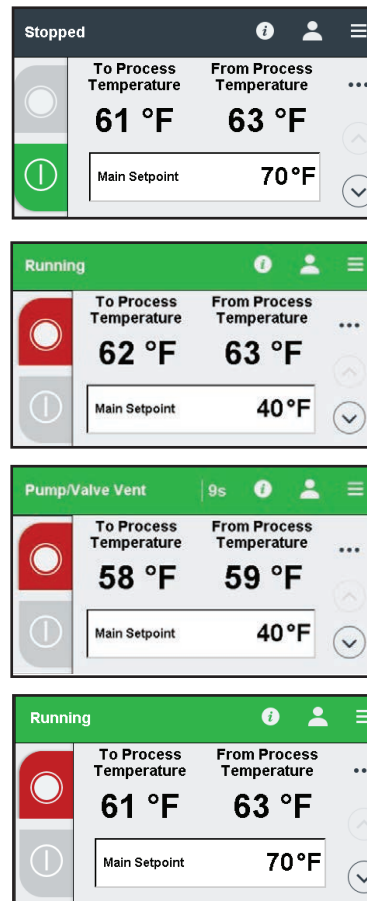

# Stopping the RQT Premium



## **WARNING: Electrical Shock and Hot Surface Hazards**



Before attempting maintenance of any kind on the RQT Premium, you must stop the unit, disconnect and lockout the main power supply, and allow the unit to cool to less than 100°F {38°C}.



### **You must shut down the RQT Premium whenever you:**

- Change the water hookups.
- Perform maintenance on the process machine.
- Purge the process circuit of the water or fluid.
- Perform routine or preventive maintenance.
- Observe a condition that requires troubleshooting.
- Relocate, ship or store the unit.
- Change the value and/or selection of configuration settings.

### **To shut down the unit during a normal interruption in production process, where no maintenance will be performed:**

- 1** Press STOP . If Shutdown Seal Saver/Auto Cool Stop is enabled, the seal saver/auto cool stop feature will cool the TCU down before shutting down. If immediate shut down is needed, press STOP again.

### **To shut down the unit to change water hookups or perform maintenance:**

- 1** Use the Seal Saver/Auto Cool Stop feature and allow the RQT Premium to cool itself to less than 100°F {38°C}. To use Seal Saver/Auto Cool Stop - select the More  icon and Auto Cool Stop. This will allow the seal/saver auto cool stop feature to cool the TCU down prior to shut down. If immediate shut down is needed, press STOP again.
- 2** Press STOP .
- 3** Shut off the cooling water supply, and relieve any pressure in the unit by lifting the relief valve lever and removing the drain plug on the bottom of the heater tank; then drain the unit of all fluid. The cooling water inlet hose can be removed to provide additional draining. For relocation and storage, make sure you eliminate all water from the tank (mixing and heater), to decrease the chance of excessive corrosion or freezing.
- 4** Once the unit is cool and depressurized, remove the water hookups.

# Stopping the RQT Premium (Continued)

To shut down the unit for relocation or storage:

- 1** Use the Seal Saver/Auto Cool Stop feature and allow the RQT Premium to cool itself to less than 100°F {38°C}
- 2** Press STOP  .
- 3** Shut off the cooling water supply, and relieve any pressure in the unit by lifting the relief valve lever and removing the drain plug on the bottom of the heater tank; then drain the unit of all fluid. The cooling water inlet hose must be removed to provide maximum draining.
- 4** Once the unit is cool and depressurized, disconnect the power supply and all water feeds.

In shipment or storage, the RQT Premium can withstand an environment between -40°F {-40°C} and 150°F {65°C} with 95% relative humidity non-condensing.

## Program Menu Accessibility

Access to certain program menu parameters are password protected to prevent unintended alteration to the program settings and parameters. The TCU is separated into 5 security level tiers, each with their own defined accessibility clearances. Security verification clearances are listed in order from most restrictive (guest) to most clearances (admin)

 **NOTE:** Default user level from factory is Operator. The default user level can be changed in Settings, Default Security Level.

- 1** Guest (Default Password is “0000”)
- 2** Operator (Default Password is “3333”)
- 3** Setup (Default Password is “2222”)
- 4** Service (Default Password is “1111”)
- 5** Administrator (Default Password is “admin”)

 **NOTE:** From the factory, the default security level is “Operator” to always permit basic operation of the machine. To fully restrict the machine operation, you may change the Default Security Level to “Guest”, only permitting unauthenticated users to STOP the machine. Alternatively, you may elevate the Default Security Level to eliminate password entry if security is not a concern.

 **NOTE:** Some parameters can only be modified and defined by Thermal Care. If there are issues with configuration settings please contact Thermal Care Customer Service for assistance.

Change Password Screen

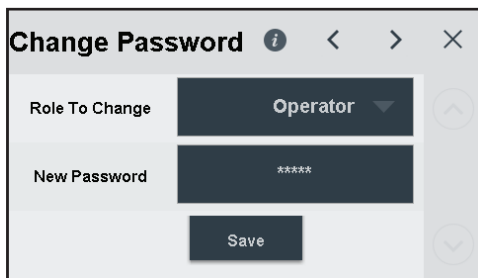

Change Auto Logout Screen

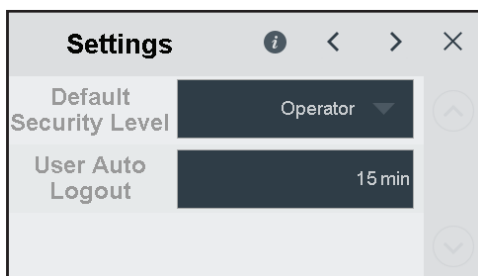

# SPI Communications (Optional)

Several members of SPI: The Plastics Industry Trade Association developed a communications standard for plastic processing equipment to communicate, which coincidentally has the same abbreviation as the trade association. This option includes an RS-485 communication port on the unit. The communication hardware firmware is SPI 3.01 standard compliant.

To activate or deactivate the SPI Communications protocol from the Home screen, tap on the hamburger icon on the top right to access the Main Menu.

Main Menu→System→Network

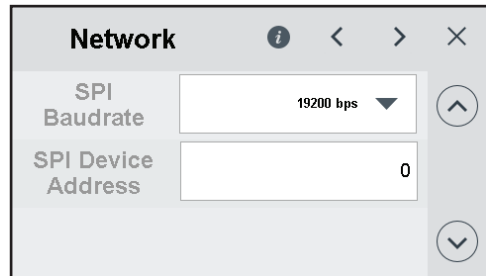
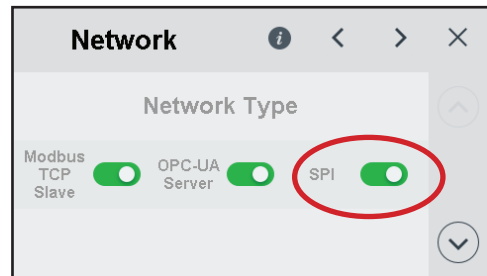
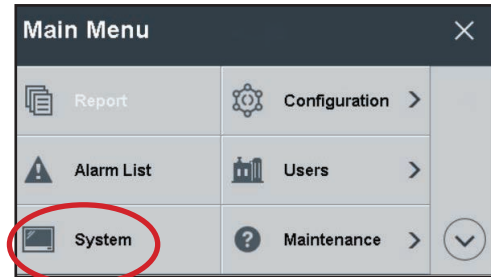
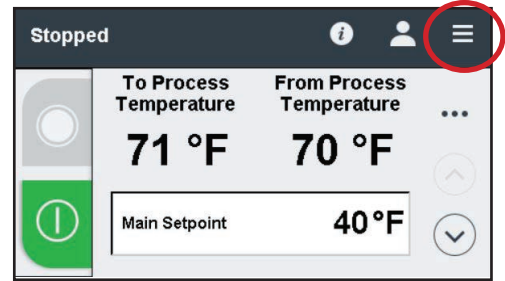





# Modbus- TCP/OPC-UA Communications (Optional)

 **NOTE:** This unit is compliant with Euromap 82.1 v1.01.

Main Menu→System→Network

 **NOTE:** DNS Server #1 IP Address and DNS Server #2 IP Address are all optional. These settings should be left as 0.0.0.0 if not utilized.

 **NOTE:** An NTP server will keep the unit's internal clock synchronized with an internet time server. This setting is optional and should be left as 0.0.0.0 if not utilized.

# SPI Option Parameters

**TIP:** If you need advanced communication details, contact Thermal Care Customer Service.

## Normal Operation

For normal operation of the RQT Premium, set the setpoint on the temperature controller using the Main Setpoint prompt on the Home screen.

On the Home screen of the TCU, the two KPI options shown defaults to the temperature display of the To/From Process temperatures. On the top left hand corner, the status bar will indicate the status of the TCU. Below are examples of various status bar options indicating a Warning (shown in yellow), an Alarm (shown in Red), Running (shown in green), and Stopped (shown in black).

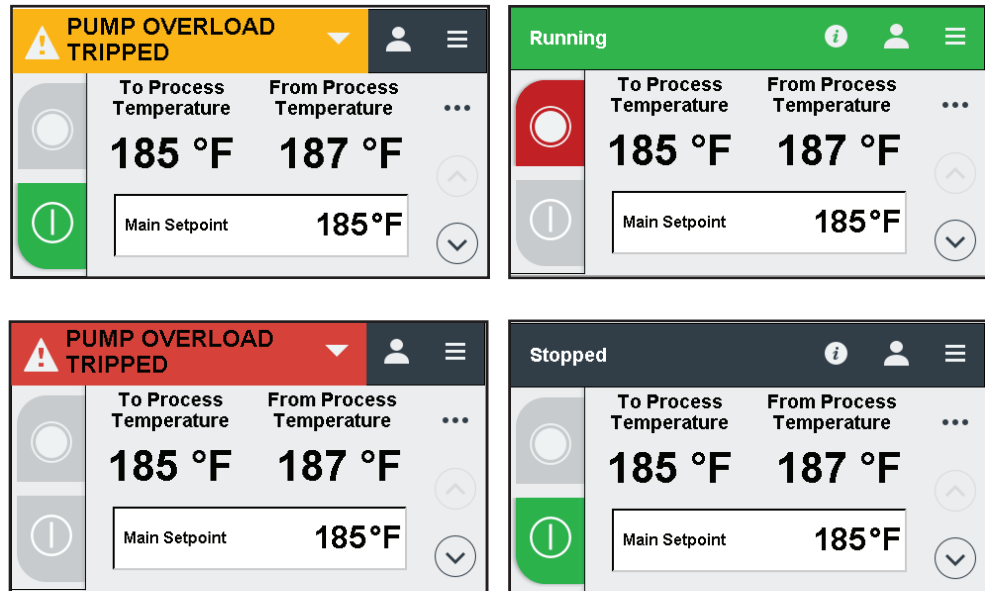

## Operation of the Screen Saver.

To select KPI to be shown on screen saver, access the Panel screen via the Main Menu (Hamburger Menu) → Configuration → Display → Push down button once, and select the desired screensaver KPI.

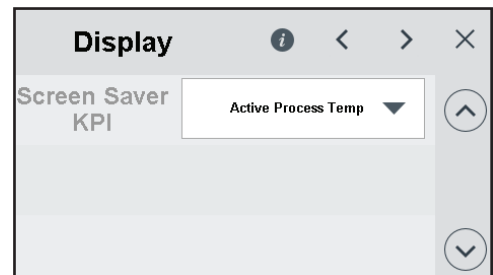

## Operation of the Screen Saver (Continued)

The screensaver background color will generally mimic the Home screen status bar color, as described below. This feature allows the general state of the TCU to be recognized at a glance from a distance.

**Black/White** = Stopped  
(or Mold Purge Active)



**Green/White** = Running  
(or Seal Saver/Auto Cool Stop Active)

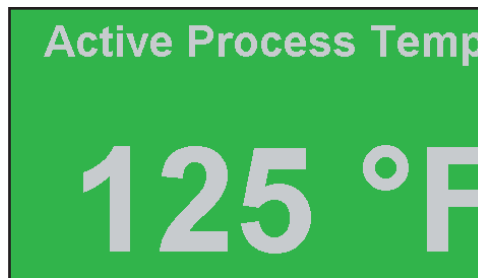

**Yellow/Black** = Active Warning



**Red/Black** = Active Alarm



To make an adjustment of screen saver timeout, access the Panel screen via the Main Menu (Hamburger Menu) → System → Push down button once, and enter the desired Screen Saver Timeout.

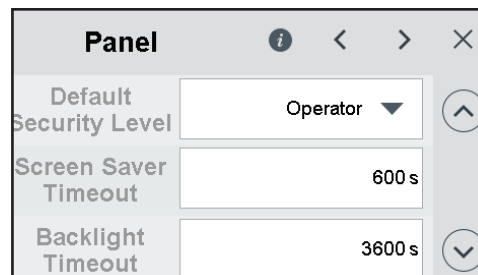

# Seal Saver/Auto Cool Stop Sequence Initiation

During this sequence, the cooling valve opens and the pump runs for 600 seconds or until the temperature reaches 100°F {38°C}, whichever occurs first. Pressing the Stop button during an Seal Aaver/Auto Cool Stop cool-down sequence stops the sequence.

This feature can also be configured to automatically execute after receiving a stop command in order to extend the life of the pump seal. Turn on “Shutdown Auto Cool Stp” to enable this automatic functionality.

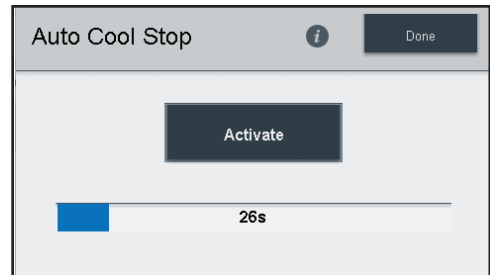
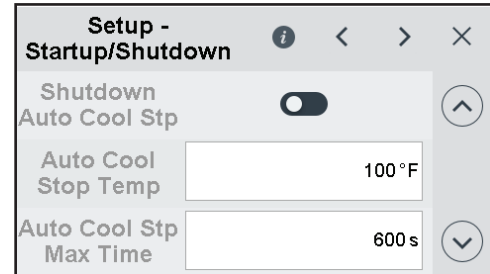

## Using the Mold Purge Option

Optional purge valve (Mold Purge) clears the process lines of fluid using compressed air. The valve is operated by an optional mold purge button on the control panel.

**IMPORTANT:** Before purging the process lines, be sure that the cooling water source feed is closed. If the feed is open and the air line has a higher pressure than the cooling water, air may be injected into the cooling water system. If the cooling water pressure is higher than the air line, cooling water may be injected into the air line.

(Continued)

# Using the Mold Purge Option (Continued)

**1** Ensure that the unit is Stopped by going to the Home screen and checking the status bar on the top left hand corner. If not, press the red stop button to stop the unit.

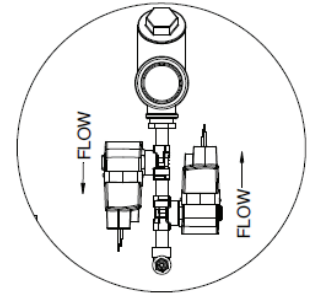
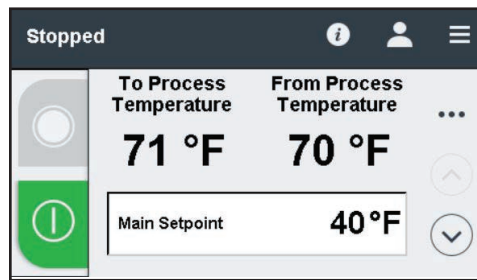

DETAIL C

**2** Shut off the cooling water supply valve.

**3** Access the mold purge option, by pressing on the (...) to access the additional settings screen and press the mold purge option.

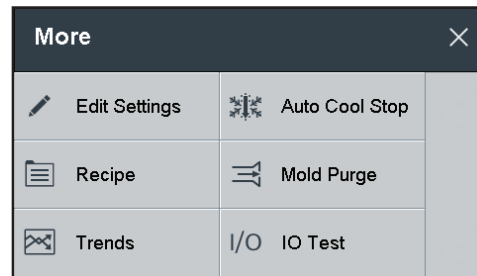

**4** Press the activate button to turn mold purge on. Note that the time required to clear the process lines of fluid will vary according to the length of the process piping and the size of the tooling so the default time setting of 600s may be longer than required for your application.

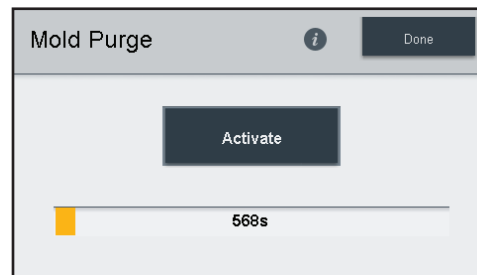

**NOTE:** Be aware that the compressed air solenoid valves may not turn on right away, as it takes some time for the modulating valve to seek the correct position in order to properly accommodate the mold purge flow.

**5** Push the depressed “Activate” button to stop Mold Purge. Or push “Done” and push red STOP button on the main screen.

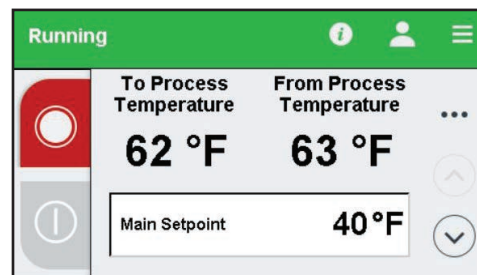

# System Maintenance

In the event that a system reset to factory settings is required, there are several options provided to reset the TCU parameters.

To access System Maintenance from the Home screen, tap on the hamburger icon to access the Main menu.

Main Menu→Maintenance→System Maintenance.

Note that these settings are only available to user security levels Setup, Service, or Admin.

## Default System Parameters

This will reset sequencing behaviors, units, networking, loop control, ramp soak parameters, and display settings.

## Default User Parameters

This will reset machine sequencing behaviors such as vent cycle times, low pressure even time outs and ramp soak parameters.

## Default Health Parameters

This will reset tracking information regarding heater contactors, valve, and pump runtime.

## Default Recipe

Resets Recipes to default settings.

## Clean Screen

Disables the touchscreen for a period of time so that the user/operator may wipe off the HMI screen.

## Calibrate Touch

Prompts the user through a series of calibrating exercises to calibrate the accuracy of the touchscreen.

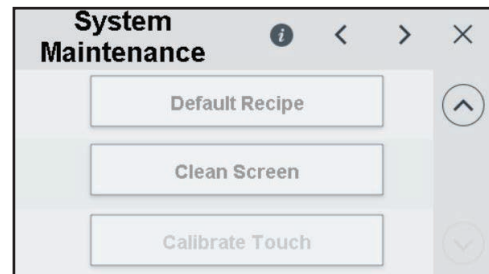
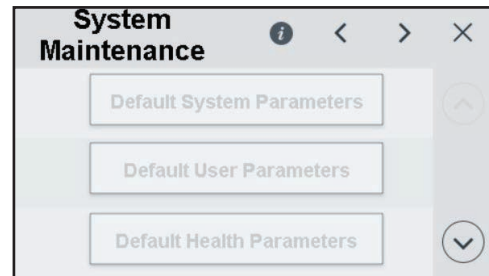

# System Maintenance (Continued)

## System Stats

To access System Stats from the Home screen, tap on the hamburger icon to access the Main menu.

Main Menu→Maintenance→System Stats.

System stats include useful realtime information regarding power usage, electrical enclosure temperature, alarm operations, low pressure events, cooling valve active times, pump run time stats, heater runtime stats, and overall run time.

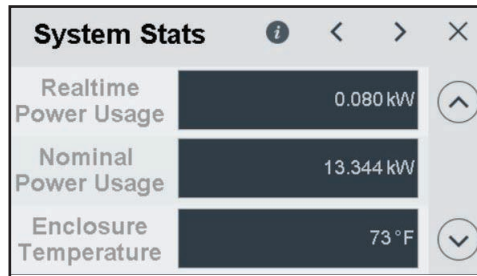

**System Stats** ⓘ < > ✕

Realtime Power Usage	0.080 kW	⬆
Nominal Power Usage	13.344 kW	
Enclosure Temperature	73°F	⬇

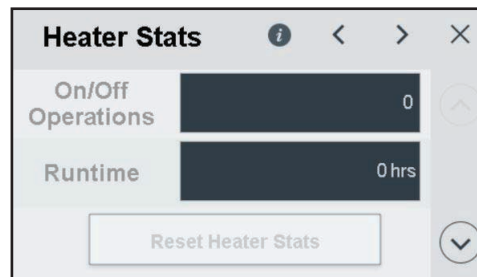

**Heater Stats** ⓘ < > ✕

On/Off Operations	0	⬆
Runtime	0 hrs	

Reset Heater Stats

⬇

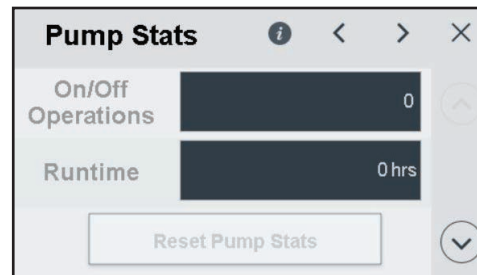

**Pump Stats** ⓘ < > ✕

On/Off Operations	0	⬆
Runtime	0 hrs	

Reset Pump Stats

⬇

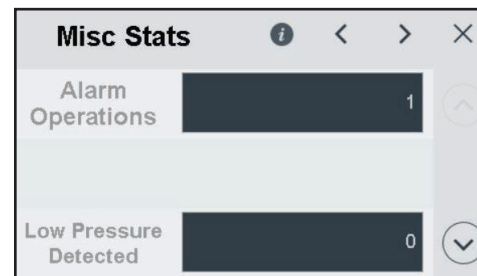

**Misc Stats** ⓘ < > ✕

Alarm Operations	1	⬆
Low Pressure Detected	0	⬇

Page intentionally left blank.



# Maintenance

---

Maintenance of Your RQT Premium .....	5-2
Preventive Maintenance Schedule.....	5-2
Accessing the RQT Premium Enclosure.....	5-3
Removing the Pump Motor and Seal (3/4-2 HP, any frequency and 3 HP, 60 Hz units) .	5-4
Reassembling the Pump Motor and Seal (3/4-2 HP, any frequency and 3 HP, 60 Hz units)	5-7
Removing the Pump Motor and Seal (3 HP, 50Hz and 5 to 10 HP, any frequency units)	5-9
Reassembling Pump Motor and Seal (3 HP, 50Hz and 5 to 10 HP, any frequency units)	5-11
Resetting Pump Overload.....	5-12
Replacing Pump Overload .....	5-12
Replacing the Heater Contactor.....	5-13
Replacing the Controller Boards.....	5-14
B&R IO Card Replacement/Additions.....	5-15

# Maintenance of Your RQT Premium

Depending on which features, options, and additions you ordered with your unit, your maintenance procedures and necessities may differ from what is shown in this User Guide. Please note that all illustrations, photos, and instructions are based on a typical configuration of a RQT Premium. Always refer to the wiring diagrams and other documentation - including manuals from the manufacturer of any valves, heat exchangers, and parts used on your RQT Premium - when completing any maintenance or troubleshooting tasks.

If you have any questions or concerns about your RQT Premium, feel free to call Thermal Care Customer Service for assistance.

## Preventive Maintenance Schedule

Once the unit is in service, we suggest following the maintenance procedures as closely as possible. The importance of a properly established preventive maintenance program cannot be overemphasized. Taking the time to follow these simple procedures will result in substantially reduced downtime, reduced repair costs, and an extended useful lifetime for the unit. RQT Premium water temperature controllers are essentially maintenance-free. However, to maintain the best performance, we recommend the following maintenance schedule.

- **Daily or as often as necessary**
  - Check for leaks in cooling and process lines.**  
Before and during operation, you should inspect the unit and all plumbing lines for leaks. If a leak develops, stop the RQT Premium and repair it.
  - Keep the unit and the area around it clean.**  
Check for and remove lint, dust, or other obstructions on the unit, especially around air vent areas. Keep floor around the unit dry. The RQT Premium exchanges air from in front of, underneath, on top and beside the unit, so make sure that nothing is against the front, bottom, top or sides of the unit that would inhibit proper ventilation around the unit.
- **Quarterly (every 3 months) or as often as necessary**
  - Inspect power cords, wires, and electrical connections.**  
Check for loose or frayed wires, burned contacts, and signs of overheated wires. Check exterior power cords to the main power source and from the electrical box to the pump and heating elements. Check the ground wire and RTD connections. Replace any wire that appears damaged or has worn or cracked insulation.
- **Every five years**
  - Replace cooling fan in electrical cabinet.**

# Accessing the RQT Premium Enclosure

Depending on which features, options, and additions you ordered with your RQT Premium, your unit may appear different and operate differently from the illustrations and photos shown in this user guide.



## **WARNING: Electrical shock and hot surface hazards.**

Before attempting maintenance of any kind on the RQT Premium, you must stop the unit, disconnect and lockout the main power supply, and allow the unit to cool to less than 100°F {38°C}.



The lockout procedure must include all energy sources:

- Electrical power supply
- Compressed air supply
- Potential energy from suspended parts
- Pressurized process fluid loop
- Cooling fluid supply
- Cooling fluid return
- Stored thermal energy
- Any other source that might cause unexpected mechanical movement or energy release

 **NOTE:** Refer to the “Zero Energy State (ZES)” section of this user guide for more information.

To access the RQT Premium enclosure:

- 1 Remove the top panel by using an 1/8” Allen key to remove the (4) screws.**



- 2 Remove right side panel by using an 1/8” Allen key to remove the (5) screws securing the panel.**



- 3 Set the top panel and side panel out of the way for maintenance procedures.**



## Removing the Pump Motor and Seal (3/4-2 HP, any frequency and 3 HP, 60 Hz units)

### Tools Required

- 9/16-inch wrench
- Flat-blade screwdriver
- 5/8 inch deep socket
- Press for removal of pump seal

### Time Required

45 Minutes

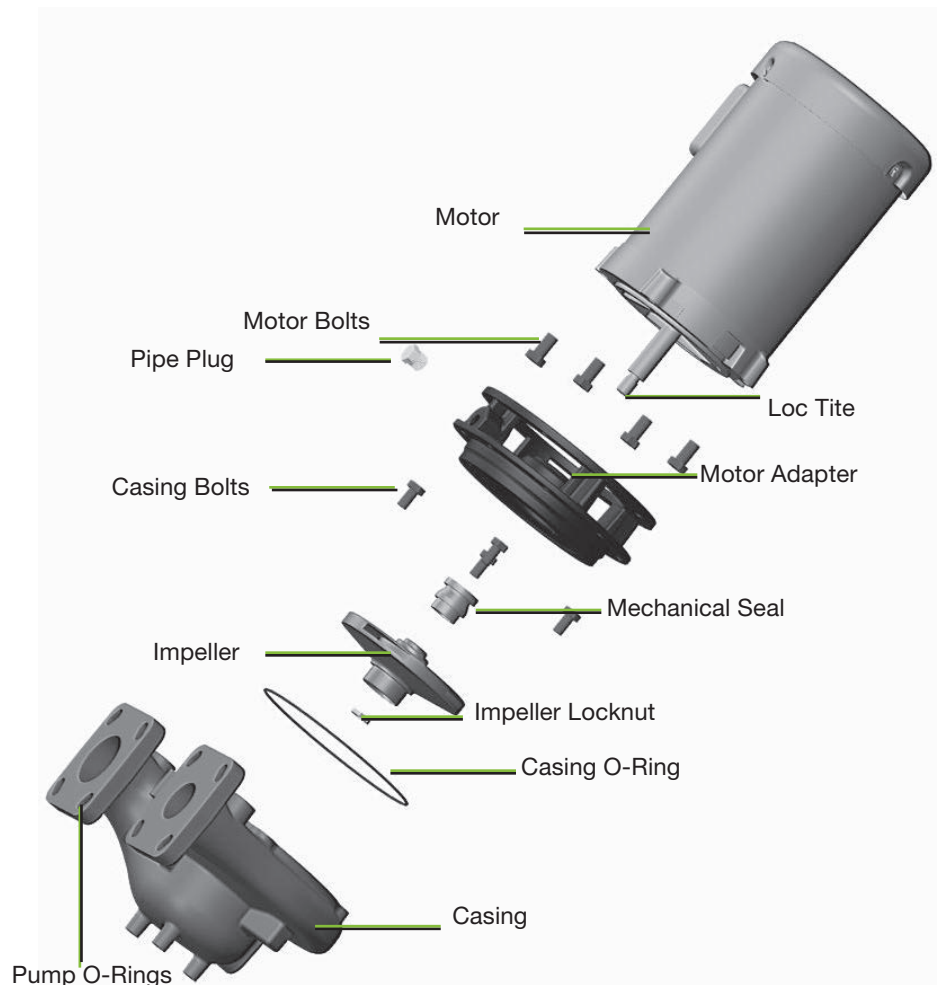

If the pump motor or seal ever needs to be replaced, the following procedure can be used on all models with 3/4-2 HP, any frequency and 3 HP, 60 Hz motors for disassembly:

- 1** Using a 9/16-inch wrench, remove the four (4) casing bolts that hold the motor and impeller adapter assembly to the RQT Premium.
- 2** Remove the motor and adapter from the pump adapter to volute.
- 3** Remove the casing O-ring. Inspect for damage or wear. If in good condition, set aside for re-use. If a new part is needed, contact Thermal Care Parts.

(Continued)

# Removing the Pump Motor and Seal (3/4-2 HP, any frequency and 3 HP, 60 Hz units)(Continued)

**4** Remove the dust cap from the bell end motor housing to expose the motor shaft.

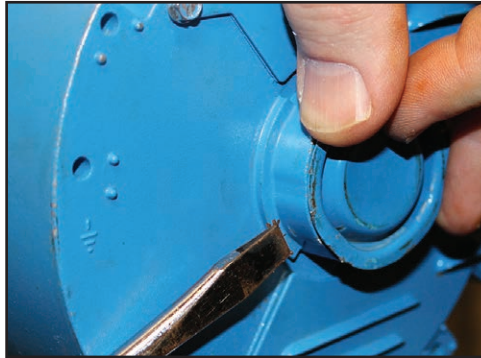

**5** Using a locking pair of pliers, grip the flat sides of the motor shaft.



**6** Remove impeller lock nut using a 5/8 inch deep socket. The lock nut is secured in place with a high performance thread locker. A significant amount of torque will be required to break it free. Use the locking pliers at the other end of the shaft to prevent shaft rotation when removing the lock nut and impeller. Standard clockwise thread is used.



**7** Unscrew the impeller from the shaft.



(Continued)

## Removing the Pump Motor and Seal (3/4-2 HP, any frequency and 3 HP, 60 Hz units) (Continued)

- 8** Slide the rotating half of the shaft seal off of the shaft. Be careful not to contaminate, chip, or scratch seal surfaces if it is to be re-used. Set seal half aside for re-use if appropriate.

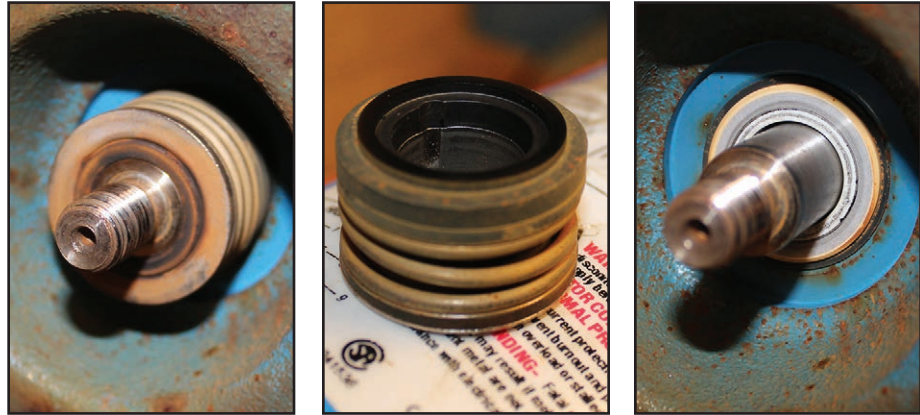

- 9** Using a 9/16-inch wrench, remove the four (4) casing bolts.



- 10** Slide motor adapter off of motor shaft.

- 11** Press stationary half of pump seal out of motor adapter, being careful not to damage rubber diametral seal or rotating/non-rotating seal interface surface. Set seal half aside for re-use if appropriate.

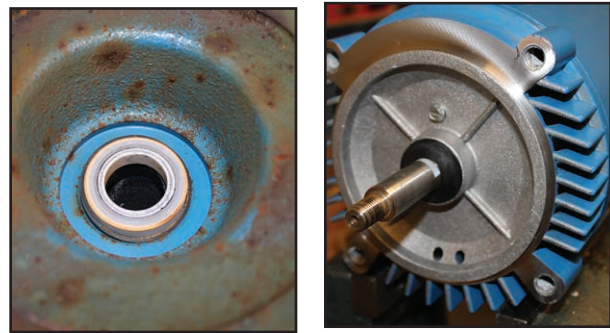

# Reassembling the Pump Motor and Seal (3/4-2 HP, any frequency and 3 HP, 60 Hz units)

The following procedure can be used on all models with 3/4-2 HP, any frequency and 3 HP, 60 Hz motors for reassembly:

- 1 Gently press stationary half of pump seal into motor adapter being careful to not damage rotating / non-rotating seal interface surface.**
- 2 Slide motor adapter assembly on to motor shaft.**

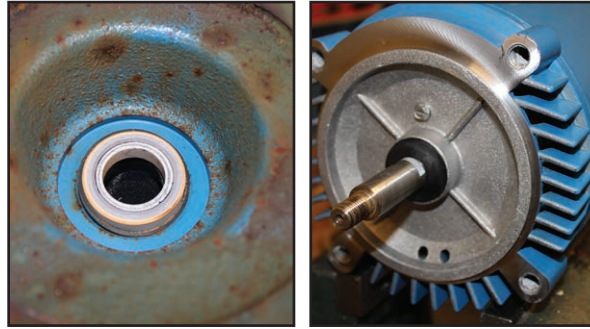

## Tools Required

- 9/16-inch wrench
- Flat-blade screwdriver
- 5/8 inch deep socket
- Blue Loc-Tite® (271)
- P-80 LUBRICANT

## Time Required

25 Minutes

- 3 Install and tighten the 4 bolts to 20 ft-lbs {27.12 N·m}. While tightening the bolts, be careful to maintain the motor adapter perpendicular to the shaft.**

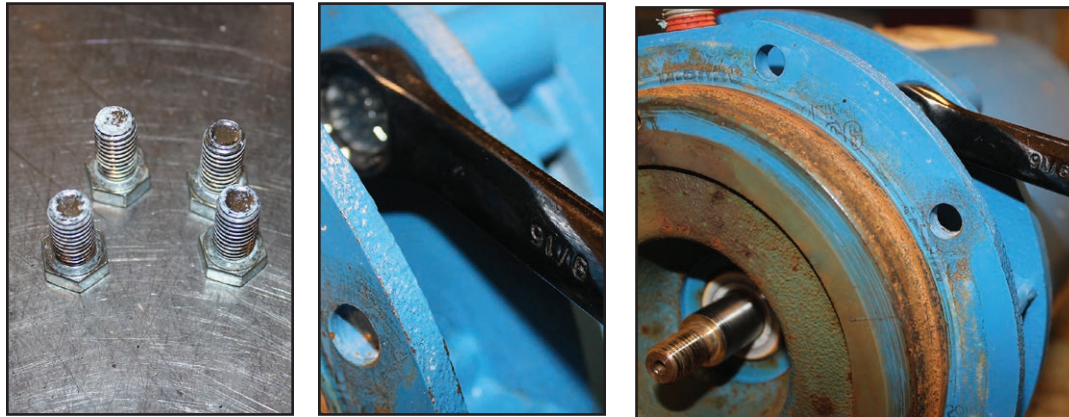

- 4 Slide the rotating portion of the shaft seal onto the shaft with the spring on the impeller side. Lubricate Motor Shaft with P-80 Lubricant. Then slide the rotating portion of the shaft seal onto the shaft with the spring on the impeller side.**

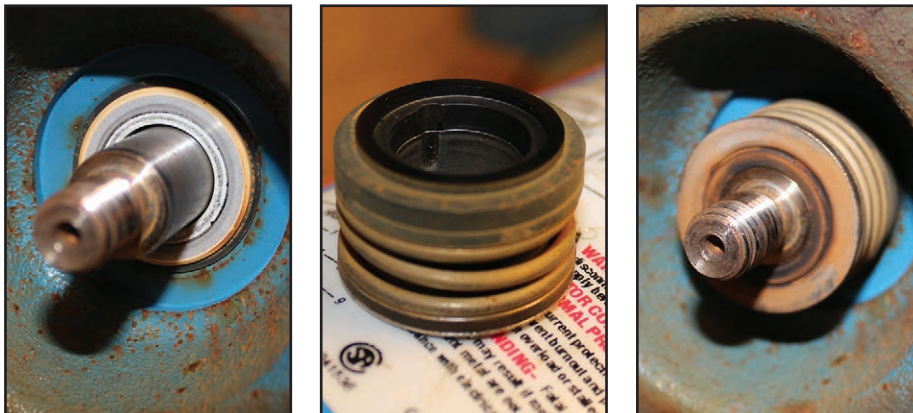

## Reassembling the Pump Motor and Seal (3/4-2 HP, any frequency and 3 HP, 60 Hz units)(Continued)

- 5** Align the impeller and screw on to shaft.



- 6** Place a small amount of Blue Loc-Tite #271 on the shaft end thread.



- 7** Install the impeller jam nut on the shaft, and tighten to 12 ft-lbs {16.27 N·m}. Use a locking pair of pliers to grip the flat side of the shaft at the motor bell end. Re-install dust cap if removed during disassembly.

**Place pump to adapter  
O-ring on motor adapter.**  
Locate the O-ring as far up  
the adapter as possible such  
that it sits tight to the angle  
formed by the mounting  
flange.

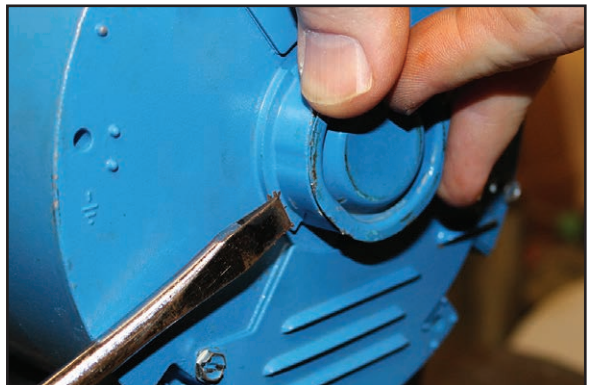

- 8** Locate the motor and motor adapter assembly on the pump volute. Install the 4 bolts, tightening to 20 ft-lbs {27.12 N·m}.



# Removing the Pump Motor and Seal (3 HP, 50Hz and 5 to 10 HP, any frequency units)

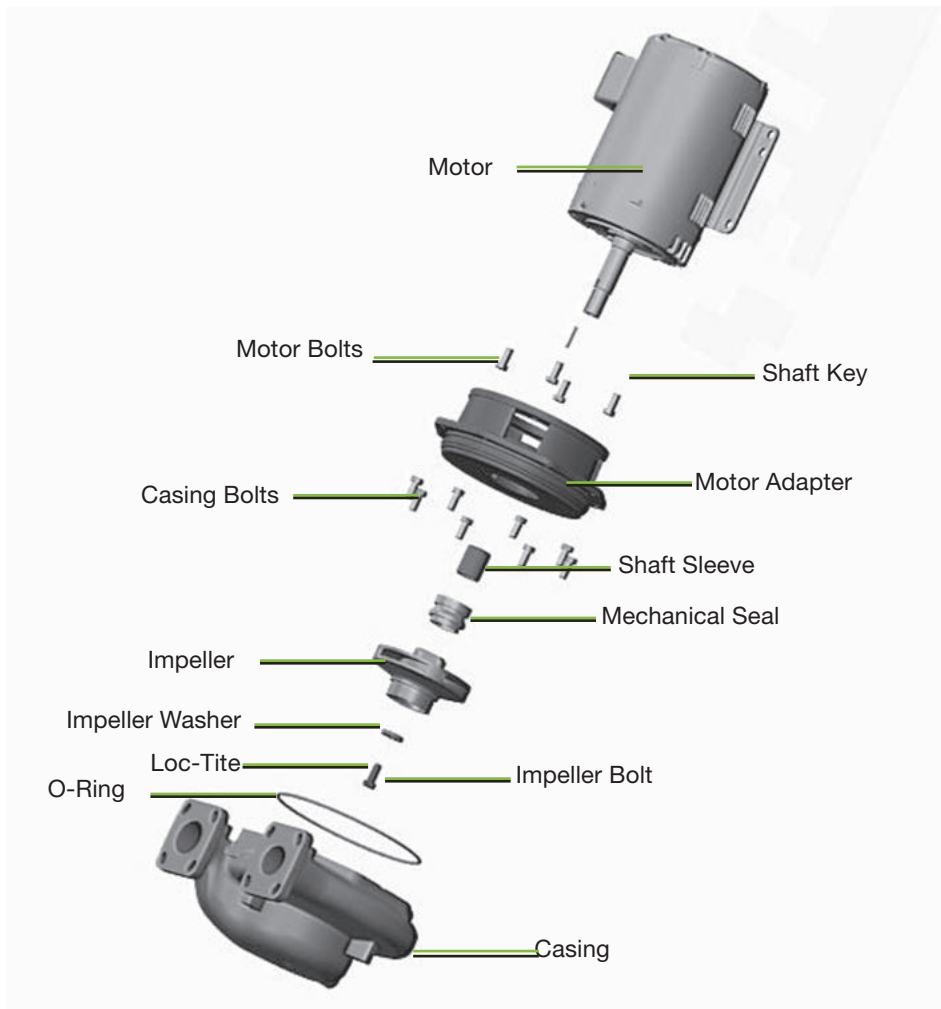

## Tools Required

- 9/16-inch wrench
- Flat-blade screwdriver
- 9/16-inch deep socket

## Time Required

20 Minutes

The following procedure can be used on all models with 3 HP, 50 Hz and 5 to 10 HP, any frequency pump motors for disassembly:

- 1 Remove eight (8) pump casing bolts using a 9/16-inch wrench.**
- 2 Remove motor and adapter from casing.**
- 3 Inspect pump casing to adapter o-ring for damage.** If appropriate obtain replacement part from the Thermal Care Parts Department.
- 4 Remove impeller bolt and washer using a 9/16-inch deep socket.** The bolt is secured in place with a high performance thread locker. A significant amount of torque will be required to break it free. The impeller may be clamped on the smallest diameter round section behind the witness line of the casing interface only. Do not damage the outside surface where the close clearance between the casing and impeller exists.

(Continued)

## Removing the Pump Motor and Seal (3 HP, 50Hz and 5 to 10 HP, any frequency units)

(Continued)



This area interfaces with volute

Witness line

Clamp in this region if needed

- 5** Pull the impeller away from the shaft by using two flat-blade screw drivers to pry the back side of the impeller away from the motor adapter.
- 6** Slide rotating half of shaft seal off of shaft. Be careful not to contaminate, chip or scratch seal surfaces if it is to be re-used. Set seal half aside for re-use if appropriate.
- 7** Slide shaft sleeve off of shaft.
- 8** Remove 4 motor bolts using 9/16-inch wrench.
- 9** Slide motor adapter off of motor shaft.
- 10** Press stationary half of pump seal out of motor adapter being careful not to damage rubber diametral seal or rotating / non-rotating seal interface surface. Set seal half aside for re-use if appropriate.

# Reassembling Pump Motor and Seal

## (3 HP, 50Hz and 5 to 10 HP, any frequency units)

The following procedure can be used on all models with 3 HP, 50 Hz and 5 to 10 HP, any frequency motors for disassembly:

- 1 Gently press stationary half of pump seal into motor adapter being careful not damage rotating / non-rotating seal interface surface.**
- 2 Slide motor adapter assembly on to motor shaft.**
- 3 Install and tighten the four (4) bolts to 37 ft lbs {50.12 N·m}. Holding the motor adapter on to the motor being careful to maintain the adapter perpendicular to the shaft.**
- 4 Slide the shaft sleeve over top of shaft.**
- 5 Lubricate Motor Shaft with P-80 Lubricant.**
- 6 Slide the rotating portion of the shaft seal on to the shaft with the spring on the impeller side.**
- 7 Align the impeller and slide on to shaft while ensuring the shaft key is in place.**
- 8 Place a small amount of Blue Loc-Tite #271 on the impeller bolt thread.**
- 9 Install the impeller bolt and washer on the shaft, tighten to 20 ft-lbs {27.12 N·m}.**
- 10 Place pump to adapter o-ring on motor adapter if removed. Locate the o-ring in the groove on the adapter without residual twist.**
- 11 Locate the motor and motor adapter assembly on the pump casing. Install the eight (8 )bolts, tightening to 37 ft-lbs {50.12 N·m}.**

### **Tools Required**

- 9/16-inch wrench
- Flat-blade screwdriver
- 9/16-inch deep socket
- Blue Loc-Tite® (271)
- P-80 Lubricant

### **Time Required**

60 Minutes

## Tools Required

- ☐ Phillips Screwdriver

## Resetting Pump Overload

The pump motor overload is located inside the unit's electrical enclosure.

- 1 Disconnect and lockout the main power.**
- 2 Open the electrical enclosure door.** Turn the screw on the front panel counterclockwise to open.
- 3 Check the overload.** Press the blue button to attempt to reset the overload. If it clicks, the overload was tripped. Verify that the overload trip point is set as specified by the electrical prints.

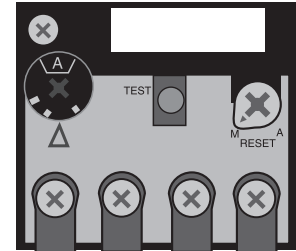

## Replacing Pump Overload

- 1 Disconnect and lockout the main power.**
- 2 Open the electrical enclosure door.** Turn the screw on the front panel counterclockwise to open.
- 3 Locate the pump overload module** attached to the pump motor starter.
- 4 Disconnect the three power leads** from the overload module to the pump motor. Note the color/placement of each lead and label as needed.
- 5 Disconnect auxiliary wiring on the overload module.** Note the wire number of each lead and the terminal where it attached to the overload.
- 6 Remove the overload module.** Loosen the three screws that connect the overload module to the motor contactor. Pull the overload module down to release it from the starter.
- 7 Reverse these steps to install the new overload module.**
- 8 Set the module reset mode to M for manual.**
- 9 Set the proper FLA trip point.** Trip point will be shown on electrical prints.
- 10 Push blue reset button** on overload to ensure it is not in the tripped state.
- 11 Verify that pump rotation is correct** (*see Installation section of this User Guide*).

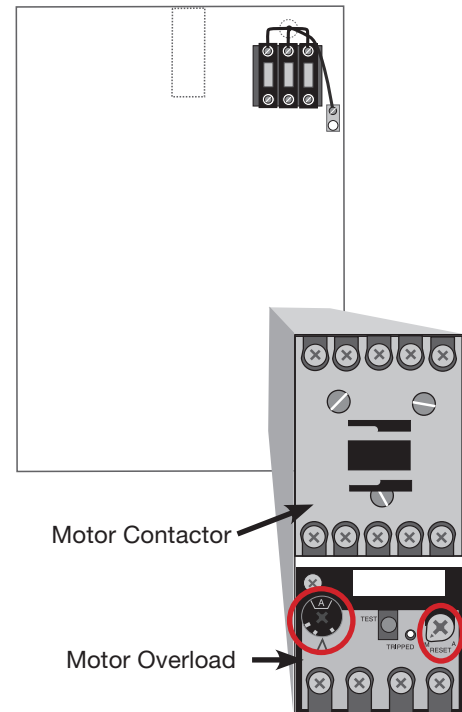

# Replacing the Heater Contactor



## **WARNING: Electrical Shock Hazard**

Only qualified service personnel who have been trained on electrical testing and the procedures for avoiding the hazards should diagnose or correct problems that require opening the unit with power on.

The heater contactors should be replaced if:

- The controller prompts you to replace the heater contactor because it is worn out.
- You have checked the continuity and found that resistance across the coil equals zero ohms or is an open circuit.
- You have checked continuity of the power legs (with the heater wires disconnected) and find them continuously connected. Or, you have checked continuity across the power legs and find an open circuit even when the coil is energized.

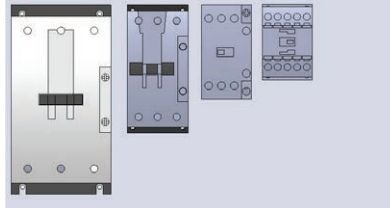

### **To replace the heater contactor:**

- 1 Disconnect and lockout the main power.**
- 2 Open the electrical enclosure door.** Turn the latch on the front panel counterclockwise to open.
- 3 Disconnect wires from the heater contactor.** Make sure you label the wires to ensure you can connect them correctly to the new contactor.
- 4 Remove the contactor** by removing the mounting screws that hold it in place.
- 5 Reverse this procedure starting with step 4 to install the new contactor.** Make sure the wires are connected correctly.

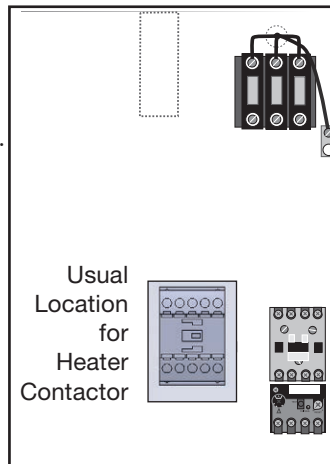

Check electrical prints for actual layout and location.

## Tools Required

- ❑ Flathead screwdriver

# Replacing the Controller Boards

The touchscreen/controller on the RQT Premium can be replaced if necessary. The controller consists of the HMI touchscreen and a series of I/O card slots located on the upper left portion of the electrical panel. If issues arise with the I/O Card modules, the controller will prompt the user with warnings/alarms to notify the user of which card/module has failed.

## To Remove the HMI Controller:

- 1 Disconnect and lockout the main power supply.**
- 2 Unplug all wired connections to the HMI controller.**
- 3 Unscrew the (3) M5X25 headless screws with a flat head screwdriver.** These screws secure the retaining clips to the electrical panel sheet metal. Ensure there is adequate space between the retaining clips and the sheet metal.
- 4 Push the retaining clips in toward the controller, push up (toward the face of the HMI Controller), and pull out to remove the retaining clip from the controller.** Repeat this step for the remaining (2) retaining clips.
- 5 Pull the HMI Controller out from the front of the TCU.**

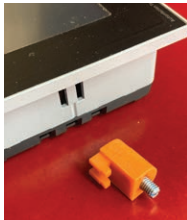
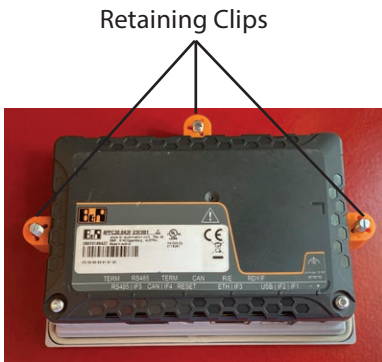

## To Reinstall the HMI Controller:

- 1 Insert the HMI Controller in the electrical panel cut-out.**
- 2 Replace the (3) retaining clips by inserting the clips into the openings on the sides of the device.**

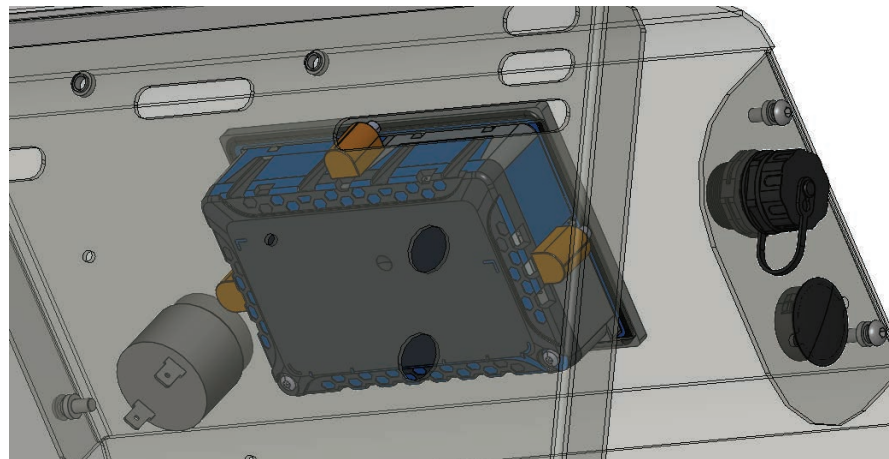

- 3 Slide the retaining clips all the way to the back of the openings.**
- 4 Secure the retaining clips to the control cabinet by tightening the screws with a flat head screwdriver.**
- 5 Reconnect wired connections to the HMI controller.**

# B&R IO Card Replacement/Additions

- 1** Power off the control and disconnect the main power.
- 2** Cards must be removed from the right end of the DIN rail to the left.



To remove each card:

- 3** To remove each card, lift the orange release tab on the card. This “unlocks” the card from the DIN rail. (0122)

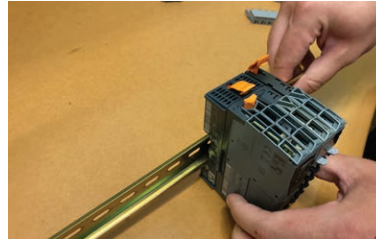

- 4** Slide the card out away from the rail. Note that each card slides into a track of the card on its left.

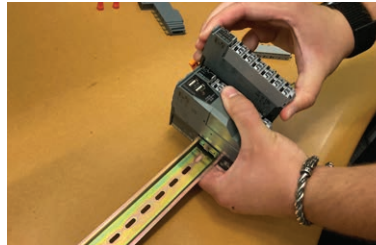

- 5** Remove the outer light grey portion (you can leave the wires attached), but pressing down on the grey tab at the top of the light grey piece. Pull from the top toward the bottom, and the bottom clip will release off of the rod.

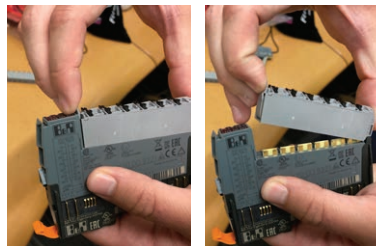

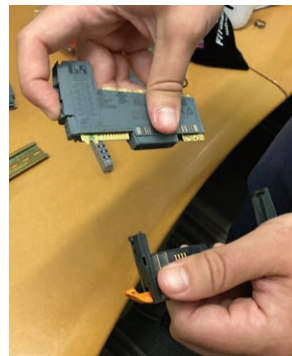
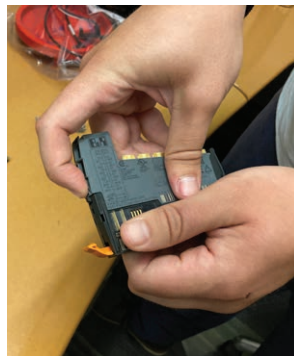
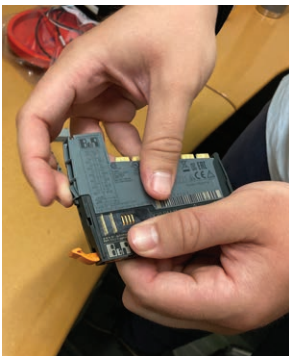

- 6** Remove the center portion of the card by pressing the top button on the medium grey portion. This releases the center section. This section is the portion you will be likely replacing.

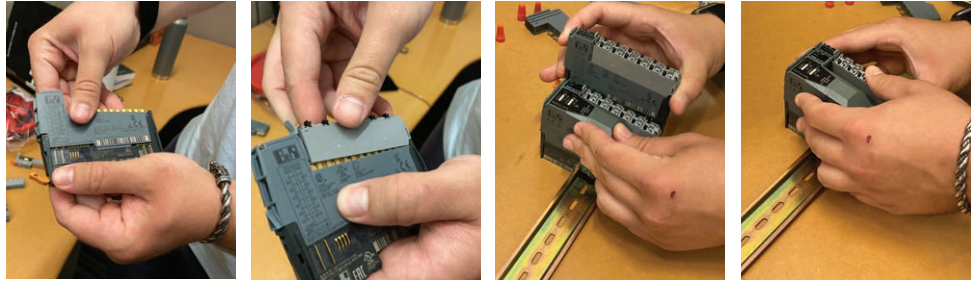

## B&R IO Card Replacement/Additions (Continued)

- 7** Reverse the process above to re-install the new card and install the card assembly onto the DIN rail.



 **NOTE:** Sometimes lining up the grooves to slide the card in can be difficult. If necessary, you can remove the light grey portion of the card on the left while re-installing the card on the right. Then re-install the light grey portion to the card on the left.

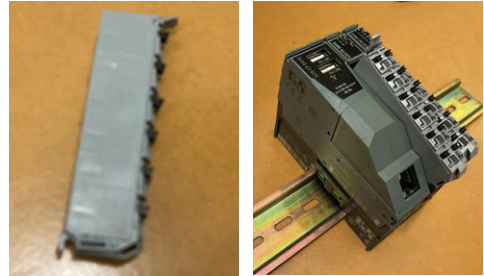

- 8** Ensure that all the orange release tabs are in their locked position, locking the cards to the DIN rail.

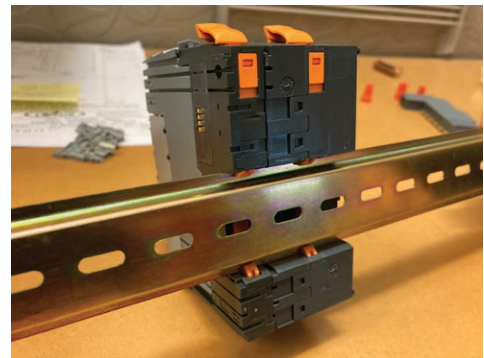



# Troubleshooting

---

Before Beginning.....	6-2
A Few Words of Caution .....	6-3
Identifying the Cause of a Problem .....	6-4
Controller Warnings .....	6-5
Controller Alarms .....	6-8
Unit Will Not Power Up.....	6-15
Troubleshooting.....	6-16
Checking the RTD .....	6-18
Replacing RTDs .....	6-20
Repairing Cooling Valves .....	6-21
Replacing Immersion Heaters .....	6-22
Removing the Pump .....	6-26
Timecode Retrieval Procedure.....	6-27

# Before Beginning

You can avoid most problems by following the recommended installation, operation and maintenance procedures outlined in this User Guide. If you have a problem, this section will help you determine the cause and tell you how to fix it.

Before you begin troubleshooting:

Additional manuals and prints for your Thermal Care equipment may be ordered through the Customer Service or Parts Department for a nominal fee. Most manuals can be downloaded free of charge from the Resource section of the Thermal Care website [www.thermalcare.com](http://www.thermalcare.com)

- Find any wiring, parts, and assembly diagrams that were shipped with your equipment. These are the best reference for correcting a problem. The diagrams will note any custom features or options not covered in this User Guide.
- Verify that you have all instructional materials related to the RQT Premium.
- Check that you have the manual for other equipment connected in the system. Troubleshooting may require investigating other equipment attached to, or connected with the RQT Premium.

 **TIP:** If you need advanced communication details contact Customer Service.

## A Few Words of Caution



**WARNING: Improper installation, operation or servicing may result in equipment damage or personal injury.**

This equipment should only be installed, adjusted, and serviced by qualified technical personnel who are familiar with the construction, operation, and potential hazards of this type of machine.

All wiring, disconnects, and fuses should be installed and adjusted by qualified electrical technicians in accordance with electrical codes in your region. Always maintain a safe ground. Do not operate the equipment at power levels other than what is specified on the machine serial tag and data plate.



**WARNING: Electrical Hazard**



Before performing maintenance or repairs on this product, disconnect and lock out electrical power sources to prevent injury from unexpected energization or start-up. A lockable device has been provided to isolate this product from potentially hazardous electricity.



**WARNING: Compressed Air Hazard**

If you use compressed air, you must wear eye protection and observe all OSHA and other safety regulations pertaining to the use of compressed air. Bleed off pressure before servicing equipment.



**WARNING: Hot Surface and Liquid Hazards.**



Before attempting maintenance of any kind on the RQT Premium, you must stop the unit, disconnect and lockout the main power supply, and allow the unit to cool to less than 100°F {38°C}.

# Identifying the Cause of a Problem

**NOTE:** Additional troubleshooting help can be found in the documentation manuals included with this User Guide.

The Troubleshooting section covers problems directly related to the operation and maintenance of the RQT Premium. This section does not provide solutions to problems that originate with other equipment. Additional troubleshooting help can be found in manuals supplied with the other equipment.

The status bar located on the top left hand corner of the controller will indicate a warning (shown with a yellow background) or an alarm (shown with a red background). The audible alarm will also activate to further alert personnel of issues. If the optional visual alarm package is installed, the strobe light will be activated as well.

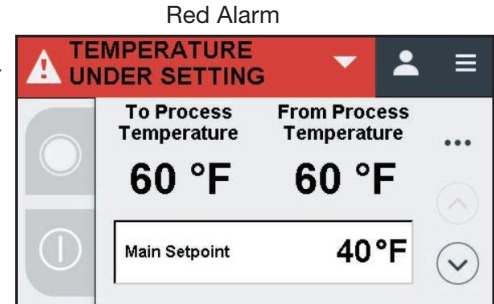

**Warnings** allow the machine to continue in its current state.  
**Alarms** cause it to cease operation.

**When an Alarm or Warning condition occurs:**

- 1 Press the drop down arrow located on the status bar next to the alarm prompt.
- 2 The issue will be displayed with a prompt displaying issues the unit is seeing.
- 3 Read the alarm. If it asks you to take immediate action, you must do so in order to not risk damage to the machine.
- 4 In order to silence the alarm, go to the Alarm List and tap on the ACK ALL icon to acknowledge the alarm and silence it, and reset it (if possible).

**NOTE:** Some severe alarms are not silenceable.

- 5 Note the alarm type as well as what the machine was doing prior or during the alarm occurrence. Was it starting up, running steadily, etc.?
- 6 Determine and fix the cause of the alarm.



**WARNING:** Always disconnect and lock out all energy sources according to local, regional, and other guidelines. Refer to the Zero Energy State information in the introduction of this User Guide before opening the RQT Premium or its electrical enclosure. Also disconnect air and water supply lines as needed.

“Alarm List” contains both warnings and alarms.

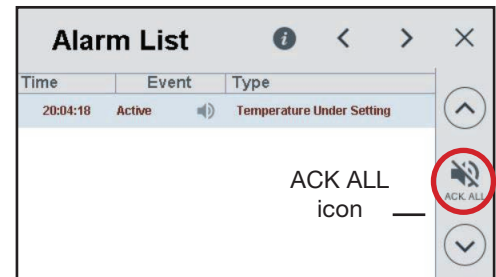

Navigating left or right will take you to the alarm history screen (showing both date/time stamped alarms and warnings).

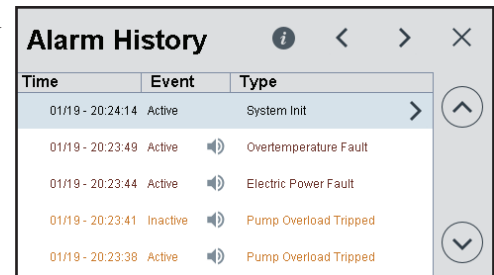

Yellow Warning

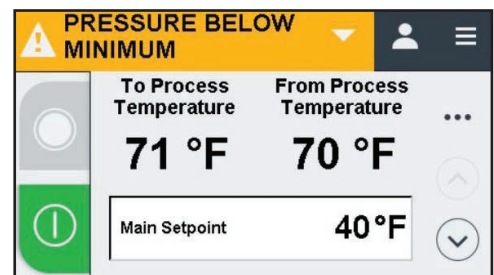

# Controller Warnings

Warning	Possible Cause	Solution
<b>PUMP OVERLOAD TRIPPED</b>	The pump overload protector has tripped from too much pump motor current. This is typically caused by excessive flow in the process loop.	<p>Check the fluid loop for too much flow or restrict it.</p> <p>Manually reset overload protector in electrical panel.</p>
<b>FLOWMETER BAD FLOW</b>	There is insufficient flow in the process loop for an extended period of time.	<p>Verify low flow trip threshold is correct.</p> <p>Verify low flow trip delay is appropriate.</p>
<b>PRESSURE BELOW MINIMUM</b>	Process fluid pressurization supply is too low or there is a leak in the process loop. If the machine was running when pressure was lost and is currently paused, it will restart automatically when pressure returns.	Check cooling water supply pressure.
<b>NEED MORE PRESS FOR THIS TEMP</b>	Process loop pressure is too low for the actual high system temperature. The process loop is pressurized by the incoming cooling water, and must remain sufficient, especially at high operating temperatures.	<p>Increase the cooling water supply pressure.</p> <p>Operate the system at a lower temperature setpoint.</p>
<b>SETPOINT TOO HIGH FOR PRESS</b>	Setpoint is too high for current system pressure.	<p>Operate the system at a lower temperature setpoint.</p> <p>Increase the cooling water supply pressure.</p>
<b>TO PROCESS PRESS SNSR HIGH</b>	A HIGH SIGNAL or OPEN/SHORT CIRCUIT has occurred on the "To Process" pressure transducer or wiring. The machine can continue to operate, but will be unable to approximate flow.	<p>Check the "To Process" pressure transducer.</p> <p>Check the analog wiring.</p>
<b>TO PROCESS PRESS SNSR LOW</b>	A LOW SIGNAL or OPEN/SHORT CIRCUIT has occurred on the "To Process" pressure transducer or wiring. The machine can continue to operate, but will be unable to approximate flow.	<p>Check the "To Process" pressure transducer.</p> <p>Check the analog wiring.</p>
<b>TO PROCESS PRESS SNSR ERR</b>	A CHANNEL FAULT has occurred on the "To Process" pressure transducer or wiring. The machine can continue to operate, but will be unable to approximate flow.	<p>Check for a malfunctioning analog input card.</p> <p>Check for extraneous voltages on the analog circuit.</p>

## Controller Warnings (Continued)

Warning	Possible Cause	Solution
<b>TO PROCESS RTD PROBE OPEN</b>	An OPEN CIRCUIT has occurred in the "To Process" RTD temperature probe or wiring. The failed probe is not controlling, so machine operation is not affected.	Check "To Process" RTD probe for an OPEN CIRCUIT.  Check for broken wiring in "To process" RTD circuit.
<b>TO PROCESS RTD PROBE SHORT</b>	A SHORT CIRCUIT has occurred in the "To Process" RTD temperature probe or wiring. The failed probe is not controlling, so machine operation is not affected.	Check "To Process" RTD probe for a SHORT CIRCUIT.  Check for shorted wiring in "From process" RTD circuit.
<b>TO PROCESS RTD PROBE ERROR</b>	A CHANNEL FAULT has occurred in the "To Process" RTD temperature probe or wiring. The failed probe is not controlling, so machine operation is not affected.	Check for a malfunctioning RTD input card.  Check for extraneous voltages on the RTD circuit.
<b>FROM PROCESS RTD PROBE OPEN</b>	An OPEN CIRCUIT has occurred in the "From Process" RTD temperature probe or wiring. The failed probe is not controlling, so machine operation is not affected.	Check "From Process" RTD probe for an OPEN CIRCUIT.  Check for broken wiring in "From process" RTD circuit.
<b>FROM PROCESS RTD PROBE SHORT</b>	A SHORT CIRCUIT has occurred in the "From Process" RTD temperature probe or wiring. The failed probe is not controlling, so machine operation is not affected.	Check "From Process" RTD probe for a SHORT CIRCUIT.  Check for shorted wiring in "From process" RTD circuit.
<b>FROM PROCESS RTD PROBE ERROR</b>	A CHANNEL FAULT has occurred in the "From Process" RTD temperature probe or wiring. The failed probe is not controlling, so machine operation is not affected.	Check for a malfunctioning RTD input card.  Check for extraneous voltages on the RTD circuit.
<b>FLOWMETER SIGNAL TOO HIGH</b>	A HIGH SIGNAL or OPEN/SHORT CIRCUIT has occurred on the FLOWMETER or wiring. The machine can continue to operate, but will be unable to measure flow or take action on low flow conditions.	Check the flowmeter.  Check the analog wiring.
<b>FLOWMETER SIGNAL TOO LOW</b>	A LOW SIGNAL or OPEN/SHORT CIRCUIT has occurred on the FLOWMETER or wiring. The machine can continue to operate, but will be unable to measure flow or take action on low flow conditions.	Check the flowmeter.  Check the analog wiring.

## Controller Warnings (Continued)

Warning	Possible Cause	Solution
<b>FLOWMETER SIGNAL ERROR</b>	A CHANNEL FAULT has occurred on the FLOWMETER or wiring. The machine can continue to operate, but will be unable to measure flow or take action on low flow conditions.	<p>Check for a malfunctioning analog input card.</p> <p>Check for extraneous voltages on the analog circuit.</p>
<b>FLASH MEMORY ERROR</b>	Flash memory writes are excessive.	Contact the Service department of the manufacturer.
<b>TEMPERATURE DEVIATION HIGH</b>	The temperature has deviated too high for too long above the setpoint. This can be caused by a machine malfunction, or an undersized machine connected to an excessive load.	<p>Check for a failed/blocked cooling valve.</p> <p>Check for a failed (stuck on) heater contactor.</p>
<b>TEMPERATURE DEVIATION LOW</b>	The temperature has deviated too low for too long below the setpoint. This can be caused by a machine malfunction, or an undersized machine connected to an excessive load.	<p>Check for a failed/stuck open cooling valve.</p> <p>Check for a failed (stuck on) heater contactor.</p>
<b>NETWORK HEARTBEAT LOST</b>	The NETWORK HEARTBEAT HAS BEEN LOST after having been initially established.	<p>Fix network or remote mode.</p> <p>Change Network Timeout action or timeout period.</p>
<b>TOO FREQUENT HEAT CYCLES</b>	The machine is being used in a manner that cycles the heaters too frequently. This will wear out the heater contactor prematurely, leading to early machine failure.	<p>The PID should be re-tuned.</p> <p>SSR-equipped model should be used for this application.</p>
<b>WORN OUT HEATER CONTACTOR</b>	The HEATER CONTACTOR is nearing the end of its operational life. Please replace the component whenever possible to eliminate this source of eventual failure.	Replace the electromechanical heater contactor.
<b>CLOCK NOT SET</b>	The DATE and TIME have not been set in the controller. Trends, schedules, warnings and alarms may not operate properly until this is completed.	Set the DATE and TIME.

## Controller Alarms NOTE: \*corresponding slot number will be identified on the controller screen.

Alarm	Possible Cause	Solution
<b>IO CONNECTION FAILURE</b>	The touchscreen controller has lost connection with all of the IO modules. The touchscreen and IO modules are interconnected via 2 conductors (plus shield). They are each supplied with 24VDC separately. All must be present for the system to function properly. See electrical prints for details.	Verify connections at touchscreen and first IO module.  Check all IO modules are powered-up/illuminated.
<b>IO MODULE LINK FAILURE</b>	IO module Slot Number* and all IO modules to its right have suffered a communication failure with the touchscreen. Connection on the left side of IO module Slot Number* is likely bad. IO modules are numbered from left to right, starting with #1 ("X20BR7300") at the leftmost position.	Check that IO modules are tightly mated to each other.  Check IO modules are seated & locked on DIN rail.
<b>IO MODULE HARDWARE MISMATCH</b>	IO module Slot Number* is not the correct part number. IO modules are numbered from left to right, starting with #1 ("X20BR7300") at the leftmost position.	Replace the IO module with the correct component.  Check for accidental mixed-up order of IO modules.
<b>IO MODULE INTERNAL FAULT</b>	IO module Slot Number* has an internal failure. IO modules are numbered from left to right, starting with #1 ("X20BR7300") at the leftmost position.	Replace the faulty IO module.  Inspect machine for root cause of IO module failure.
<b>IO POINT FAILURE</b>	IO module Slot Number* type NN point # (X) has an internal failure. IO modules are numbered from left to right, starting with #1 ("X20BR7300") at the leftmost position. IO points are numbered starting with "#1". See electrical prints for details.	Replace the faulty IO module.  Inspect machine for root cause of IO module failure.
<b>POWER SUPPLY VOLTAGE LOW</b>	The 24VDC power supply voltage going to the IO modules is low. This 24VDC power is connected to terminals 15 (+) and 16 (-) of module #1 ("X20BR7300").	Check for voltage and wiring integrity.
<b>LOGIC SUPPLY VOLTAGE LOW</b>	The logic power supply for the IO modules is low. The logic supply is generated by the leftmost module #1 ("X20BR7300").	Check connections between all IO modules & 24VDC.  Replace module #1 ("X20BR7300").



## Controller Alarms (Continued)

 **NOTE:** \*corresponding slot number will be identified on the controller screen.

Alarm	Possible Cause	Solution
<b>OVER-TEMPERATURE FAULT</b>	DISCONNECT POWER TO THE MACHINE! A hardware overtemperature condition has been detected by a missing digital input which is normally energized. This input is typically jumpered to +24VDC, but may be connected through internal optional components (SSRs) or external components at the installation.	<p>Check for missing jumper or external equipment.</p> <p>Check for failed cooling fan / blocked airflow on SSRs.</p>
<b>HEATER CONTACTR STUCK CLOSED</b>	DISCONNECT POWER TO THE MACHINE! The heater contactor has been detected as stuck closed (energized). Cooling water is being introduced and circulated intentionally to cool the heater. The heater contactor has likely welded closed due to overuse or end-of-life.	<p>Replace the faulty heater contactor.</p> <p>Check wiring on heater contactor coil &amp; aux contacts.</p>
<b>TEMPERATURE OVER LIMIT</b>	DISCONNECT POWER TO THE MACHINE! The process loop has exceeded the maximum permitted temperature. Cooling water is being introduced and circulated intentionally to cool the loop. This could be caused by an internal malfunction or oversized external heat source.	<p>Replace faulty cooling valve or cooling water supply.</p> <p>Replace faulty heater contactor.</p>
<b>ELECTRIC POWER FAULT</b>	There is a problem with the incoming 3-phase electrical power. This is likely due to reverse phase rotation, a missing phase, or a low leg. For reverse phase rotation, swap any two phases on the incoming power. (This is hazardous work and must be performed by a qualified electrician).	<p>Correct reverse phase rotation or missing phase.</p> <p>Replace blown pump fuse (if equipped).</p>
<b>PUMP CONTACTOR STUCK CLOSED</b>	DISCONNECT POWER TO THE MACHINE! The pump contactor has been detected as stuck closed (energized). The pump contactor has likely welded closed due to overuse or end-of-life.	<p>Replace the faulty pump contactor.</p> <p>Check wiring on pump contactor coil &amp; aux contacts.</p>
<b>HEATER CONTACTR STUCK OPEN</b>	The heater contactor has been detected as stuck open (deenergized). The heater contactor likely has a faulty/open coil circuit, or there is mechanical binding on its internal armature which is preventing movement.	<p>Replace the faulty heater contactor.</p> <p>Check wiring on heater contactor coil &amp; aux contacts.</p>
<b>PUMP CONTACTOR STUCK OPEN</b>	The pump contactor has been detected as stuck open (deenergized). The pump contactor likely has a faulty/open coil circuit, or there is mechanical binding on its internal armature which is preventing movement.	<p>Replace the faulty pump contactor.</p> <p>Check wiring on pump contactor coil &amp; aux contacts.</p>

(Continued)

## Controller Alarms (Continued)

 **NOTE:** \*corresponding slot number will be identified on the controller screen.

Alarm	Possible Cause	Solution
<b>SYSTEM PRESSURE TOO HIGH</b>	Excessive pressure has been detected in the process loop. The source of this pressure is likely from the cooling water supply. This condition can also be caused by a check valve installed on the cooling water inlet without pressure transducers to automatically relieve thermally-induced pressure.	Reduce cooling water pressure.  Check for stuck closed cooling valve.
<b>ELEC PANEL TOO HOT</b>	Excessive temperature has been detected in the electrical panel. This will lead to component failure or erratic operation. The temperature is sensed within the touch-screen controller.	Replace the failed electrical panel cooling fan.  Check for hot ambient or blocked intake/exhaust vents.
<b>TEMPERATURE UNDER LIMIT</b>	The process loop has dropped below the minimum permitted temperature. This could be caused by a low ambient temperature, excessive cooling, or oversized external cooling load. In rare cases, it could also be caused by a malfunctioning RTD temperature sensor.	Check for excessively low ambient or large cooling load.  Repair stuck-open cooling valve and/or faulty heater.
<b>BROWNOUT OCCURRED</b>	The machine lost incoming power while it was in operation. This alarm was triggered because the machine was configured to do so. To change this behavior, adjust the "Brownout Monitor" settings in "Setup" within the "Configuration" menu.	Establish reliable electric power while in operation.  Disable fault in "Machine Configuration" if undesired.
<b>TEMPERATURE OVER SETTING</b>	The process loop has exceeded the maximum limit alarm as configured by the operator. This could be caused by loss of cooling water or excessive external heat load. It could also be an incorrectly configured limit alarm, which is set in "Alarms" within the "Configuration" menu.	Check for loss of cooling water or faulty cooling valve.  Revise the alarm setting to be more appropriate.
<b>TEMPERATURE UNDER SETTING</b>	The process loop has dropped below the minimum limit alarm as configured by the operator. This could be caused by excessive cooling water or excessive external cooling load. It could also be an incorrectly configured limit alarm, which is set in "Alarms" within the "Configuration" menu.	Check for malfunctioning heater or excessive cool load.  Revise the alarm setting to be more appropriate.
<b>LOW PRESSURE SHUTDOWN</b>	Low pressure has been present at the "From Process" port for an excessive amount of time, causing the machine to stop and not execute an automatic restart. There is likely a fault in the external plumbing, such as low pressure or a closed valve.	Check city/tower/pressure supply or for a leak.  Stop machine properly (don't just turn off water).

## Controller Alarms (Continued)

 **NOTE:** \*corresponding slot number will be identified on the controller screen.

Alarm	Possible Cause	Solution
<b>LOW PRESSURE TOO MANY EVENTS</b>	There have been too many low pressure events (NN) within a short amount of time (X). The cooling water plumbing to the equipment is likely too small and is unable to maintain sufficient pressure during operations, or other equipment is consuming too much flow simultaneously.	The plumbing to the machine is likely insufficient.  Check city/tower/pressure supply or for a leak.
<b>PUMP OVERLOAD TRIPPED</b>	The pump overload protector has tripped from too much pump motor current. This is typically caused by excessive flow in the process loop.	Check the fluid loop for too much flow or restrict it.  Manually reset overload protector in electrical panel.
<b>FLOWMETER LOW FLOW</b>	There is insufficient flow in the process loop for an extended period of time.	Verify low flow trip threshold is correct.  Verify low flow trip delay is appropriate.
<b>TO PROCESS RTD PROBE OPEN</b>	An OPEN CIRCUIT has occurred in the "To Process" RTD temperature probe or wiring. To utilize a different process sensor until it can be repaired, select a different "Process Value Source" in "Setup" within the "Configuration" menu.	Check the "To Process" RTD probe for an OPEN CIRCUIT.  Check for broken wiring in "To Process" RTD circuit.
<b>TO PROCESS RTD PROBE SHORT</b>	A SHORT CIRCUIT has occurred in the "To Process" RTD temperature probe or wiring. To utilize a different process sensor until it can be repaired, select a different "Process Value Source" in "Setup" within the "Configuration" menu.	Check "To Process" RTD probe for a SHORT CIRCUIT.  Check for shorted wiring in "To Process" RTD circuit.
<b>TO PROCESS RTD PROBE ERROR</b>	A CHANNEL FAULT has occurred in the "To Process" RTD temperature probe or wiring. To utilize a different process sensor until it can be repaired, select a different "Process Value Source" in "Setup" within the "Configuration" menu.	Check for a malfunctioning RTD input card.  Check for extraneous voltages on the RTD circuit.
<b>FROM PROCESS RTD PROBE OPEN</b>	An OPEN CIRCUIT has occurred in the "From Process" RTD temperature probe or wiring. To utilize a different process sensor until it can be repaired, select a different "Process Value Source" in "Setup" within the "Configuration" menu.	Check "From Process" RTD probe for an OPEN CIRCUIT.  Check for broken wiring in "From process" RTD circuit.

## Controller Alarms (Continued)

 **NOTE:** \*corresponding slot number will be identified on the controller screen.

Alarm	Possible Cause	Solution
<b>FROM PROCESS RTD PROBE SHORT</b>	A SHORT CIRCUIT has occurred in the "From Process" RTD temperature probe or wiring. To utilize a different process sensor until it can be repaired, select a different "Process Value Source" in "Setup" within the "Configuration" menu.	Check "From Process" RTD probe for a SHORT CIRCUIT.  Check for shorted wiring in "From process" RTD circuit.
<b>FROM PROCESS RTD PROBE ERROR</b>	A CHANNEL FAULT has occurred in the "From Process" RTD temperature probe or wiring. To utilize a different process sensor until it can be repaired, select a different "Process Value Source" in "Setup" within the "Configuration" menu.	Check for a malfunctioning RTD input card.  Check for extraneous voltages on the RTD circuit.
<b>REMOTE RTD PROBE OPEN</b>	An OPEN CIRCUIT has occurred in the "Remote" RTD temperature probe or wiring. To utilize a different process sensor until it can be repaired, select a different "Process Value Source" in "Setup" within the "Configuration" menu.	Check the "Remote" RTD probe for an OPEN CIRCUIT.  Check for broken wiring in "Remote" RTD circuit.
<b>REMOTE RTD PROBE SHORT</b>	A SHORT CIRCUIT has occurred in the "Remote" RTD temperature probe or wiring. To utilize a different process sensor until it can be repaired, select a different "Process Value Source" in "Setup" within the "Configuration" menu.	Check the "Remote" RTD probe for a SHORT CIRCUIT.  Check for shorted wiring in "Remote" RTD circuit.
<b>REMOTE RTD PROBE ERROR</b>	A CHANNEL FAULT has occurred in the "Remote" RTD temperature probe or wiring. To utilize a different process sensor until it can be repaired, select a different "Process Value Source" in "Setup" within the "Configuration" menu.	Check for a malfunctioning RTD input card.  Check for extraneous voltages on the RTD circuit.
<b>PRESSURE BELOW MINIMUM</b>	Process fluid pressurization supply is too low or there is a leak in the process loop. The machine has been configured to NOT restart automatically if low pressure. To change this, select different actions for "Adaptive Max Setpoint" in "Setup" within the "Configuration" menu.	Check cooling water supply pressure.
<b>NEED MORE PRESS FOR THIS TEMP</b>	Process loop pressure is too low for the actual high system temperature. The process loop is pressurized by the incoming cooling water, and must remain sufficient, especially at high operating temperatures.	Increase the cooling water supply pressure.  Operate the system at a lower temperature setpoint.

## Controller Alarms (Continued)

 **NOTE:** \*corresponding slot number will be identified on the controller screen.

Alarm	Possible Cause	Solution
<b>FROM PROCESS PRESS SNSR HIGH</b>	A HIGH SIGNAL or OPEN/SHORT CIRCUIT has occurred on the "From Process" pressure transducer or wiring. This sensor is required for machine operation.	Check the "From Process" pressure transducer.  Check the analog transducer wiring.
<b>FROM PROCESS PRESS SNSR LOW</b>	A LOW SIGNAL or OPEN/SHORT CIRCUIT has occurred on the "From Process" pressure transducer or wiring. This sensor is required for machine operation.	Check the "From Process" pressure transducer.  Check the analog transducer wiring.
<b>FROM PROCESS PRESS SNSR ERR</b>	A CHANNEL FAULT has occurred on the "From Process" pressure transducer or wiring. This sensor is required for machine operation.	Check for a malfunctioning analog input card.  Check for extraneous voltages on the analog circuit.
<b>TO PROCESS PRESS SNSR HIGH</b>	A HIGH SIGNAL or OPEN/SHORT CIRCUIT has occurred on the "To Process" pressure transducer or wiring.	Check the "To Process" pressure transducer.  Check the analog transducer wiring.
<b>TO PROCESS PRESS SNSR LOW</b>	A LOW SIGNAL or OPEN/SHORT CIRCUIT has occurred on the "To Process" pressure transducer or wiring.	Check the "To Process" pressure transducer.  Check the analog transducer wiring.
<b>TO PROCESS PRESS SNSR ERR</b>	A CHANNEL FAULT has occurred on the "To Process" pressure transducer or wiring.	Check for a malfunctioning analog input card.  Check for extraneous voltages on the analog circuit.
<b>FLOWMETER SIGNAL TOO HIGH</b>	A HIGH SIGNAL or OPEN/SHORT CIRCUIT has occurred on the FLOWMETER or wiring. To continue machine operation, please disable the flowmeter in "Component Configuration" within the "Configuration" menu.	Check the flowmeter.  Check the analog wiring.
<b>FLOWMETER SIGNAL TOO LOW</b>	A LOW SIGNAL or OPEN/SHORT CIRCUIT has occurred on the FLOWMETER or wiring. To continue machine operation, please disable the flowmeter in "Component Configuration" within the "Configuration" menu.	Check the flowmeter.  Check the analog wiring.
<b>FLOWMETER SIGNAL ERROR</b>	A CHANNEL FAULT has occurred on the FLOWMETER or wiring. To continue machine operation, please disable the flowmeter in "Component Configuration" within the "Configuration" menu.	Check for a malfunctioning analog input card.  Check for extraneous voltages on the analog circuit.

## Controller Alarms (Continued)

 **NOTE:** \*corresponding slot number will be identified on the controller screen.

Alarm	Possible Cause	Solution
<b>TEMPERATURE DEVIATION HIGH</b>	The temperature has deviated too high for too long above the setpoint. This can be caused by a machine malfunction, or an undersized machine connected to an excessive load.	Check for a failed/blocked cooling valve.  Check for a failed (stuck on) heater contactor.
<b>TEMPERATURE DEVIATION LOW</b>	The temperature has deviated too low for too long below the setpoint. This can be caused by a machine malfunction, or an undersized machine connected to an excessive load.	Check for a failed/stuck open cooling valve.  Check for a failed heater contactor.
<b>NETWORK HEARTBEAT LOST</b>	The NETWORK HEARTBEAT HAS BEEN LOST after having been initially established.	Fix network or remote node.  Change Network Timeout action or timeout period.
<b>RAMP/SOAK INTERRUPTED</b>	The Ramp/Soak sequence was interrupted by a low pressure condition for too long. The machine will not execute an automatic restart since it would disrupt the sensitive Ramp/Soak sequence that it was attempting to execute.	Check city/tower/pressure supply or for a leak.  Check external plumbing for robustness and pressure.

\*corresponding slot number will be identified on the controller screen.

# Unit Will Not Power Up

If you apply power to the machine, and switch ON the disconnect switch (if equipped), and the touch-screen controller does not light, you have a problem with the main power circuit or the unit's temperature controller.



**WARNING: Electrical Shock Hazard**  
**Disconnect and lockout the main power supply before proceeding.**

Symptom	Possible Cause	Solution
Applying power does not illuminate the temperature controller display.	Is power reaching the RQT Premium?	Verify that the main power supply, machine disconnect switch (if equipped), and any customer-installed electrical disconnect switch are in the ON position.  Verify correct electrical connections between the unit and the power supply.  Replace any damaged wires or cables.
	Is the correct voltage reaching the RQT Premium?	Check the electrical requirements on the unit nameplate.  Verify correct main supply voltage to the unit and the secondary voltage supply from the power supply to unit components.  Replace the power supply, if necessary.
	Is a fuse blown?	Troubleshoot relevant internal control fuses shown on electrical prints.  Check external power fuses, especially the ones located in the customer-installed fused disconnect switch.

# Troubleshooting

Symptom	Possible Cause	Solution
<p><b>Alternating overheating and overcooling or rapid cycling from heat to cool.</b></p>	<p>Poor water flow.</p>	<p>Check connectors and increase size if necessary. If there are a large number of hoses and/or they are long, try to shorten hose runs and use as large of a hose as possible to minimize water-circuit pressure drop. If quick disconnects with check valves are used, remove the check valves to reduce pressure drop through water circuit.</p>
	<p>Poorly tuned PID loop.</p>	<p>Re-tune the PID loop. <i>See section PID Parameters in Appendix B.</i></p>
	<p>Poor connection or failure of RTD.</p>	<p>Check connection, replace if necessary.</p>
	<p>Failure of the microprocessor.</p>	<p>Replace controller or IO cards.</p>
<p><b>Unable to heat properly.</b></p>	<p>Cooling valve is stuck in the open position.</p>	<p>Use the IO Test screen, which is made for this exact situation.</p>
	<p>Leaking connection and/or the manual pressure relief valve is in an open condition.</p>	<p>Check for leaks and replace any faulty valves.</p>
	<p>Immersion heater is inoperative</p>	<p>Have a qualified electrician check to see if the heater and/or heater contactor are functioning correctly and replace any defective components.</p>
	<p>Failure of the microprocessor.</p>	<p>Replace controller or IO cards.</p>
	<p>Failure of RTD.</p>	<p>Replace RTD.</p>

(Continued)



# Troubleshooting (Continued)

**IMPORTANT:** Always refer to the wiring diagrams that came with your RQT Premium to locate specific electrical components. Illustrations in the User Guide are intended to be representative only.

Symptom	Possible Cause	Solution
Unable to cool properly.	Cooling water supply is not sufficient.	Check to make sure the cooling water supply is of sufficient temperature, volume and pressure for the unit.
	Drain (cooling water return line) is not sufficient.	Check the drain (cooling water return line) to ensure there is no restriction preventing water flow to the drain.
	Cooling valve is inoperative.	Use IO test to control cooling valve.
	Plugged heat exchanger (only on models with heat exchanger option).	Clean or replace heat exchanger.
	High backpressure in the cooling water system	Reduce backpressure.
Heater failure.	Unit not filled with water.	Fill unit with water.
	Faulty heater.	Replace heater.
	Plugged heater tube / flow restriction.	Clear obstruction.
	Pressure relief valve stuck in open position.	Replace valve.
	Heater overheated due to air entrapment in process loop.	Ensure that air cannot get trapped in process loop, or install air removal devices to mitigate this problem in the future. Contact Customer Service for more information.

# Checking the RTD



## **WARNING: Electrical Shock Hazard**



Only qualified service personnel who have been trained on electrical testing and the procedures for avoiding the hazards should diagnose or correct problems that require opening the unit with power on.

The RQT Premium uses a Pt1000 RTD to monitor the “To Process” and “From Process” temperature. It also uses a Pt1000 RTD for the remote RTD (if equipped). One Pt1000 RTD is installed in the wall of the heater tank at the “to process” outlet. The other is installed in the mixing tank (or heat exchanger) near the “From Process” outlet.

### **To check a RTD after a sensor error:**

- 1 Disconnect and lockout the main power.** Refer to the “Zero Energy State (ZES)” information in the introduction of this User Guide.
- 2 Open the electrical enclosure door.** Turn the screw on the front panel counterclockwise to open.
- 3 Remove RTD wiring from controller I/O (slice) terminal strip.** Refer to the wiring diagrams that came with your unit.
- 4 Verify the resistance of the RTD using a VOM. Polarity does not matter. If incorrect, replace.** *Refer to the table on the next page.*

(Continued)

# Checking the RTD (Continued)

## Pt1000

Temp T	Resistance at T	Resistance at T+1°F	Resistance at T+2°F	Resistance at T+3°F	Resistance at T+4°F	Resistance at T+5°F	Resistance at T+6°F	Resistance at T+7°F	Resistance at T+8°F	Resistance at T+9°F	Temp T
°F	Ohms	Ohms	Ohms	Ohms	Ohms	Ohms	Ohms	Ohms	Ohms	Ohms	°C
30°F	996Ω	998Ω	1,000Ω	1,002Ω	1,004Ω	1,007Ω	1,009Ω	1,011Ω	1,013Ω	1,015Ω	-1.1°C
40°F	1,017Ω	1,020Ω	1,022Ω	1,024Ω	1,026Ω	1,028Ω	1,030Ω	1,033Ω	1,035Ω	1,037Ω	4.4°C
50°F	1,039Ω	1,041Ω	1,043Ω	1,046Ω	1,048Ω	1,050Ω	1,052Ω	1,054Ω	1,056Ω	1,058Ω	10.0°C
60°F	1,061Ω	1,063Ω	1,065Ω	1,067Ω	1,069Ω	1,071Ω	1,074Ω	1,076Ω	1,078Ω	1,080Ω	15.6°C
70°F	1,082Ω	1,084Ω	1,087Ω	1,089Ω	1,091Ω	1,093Ω	1,095Ω	1,097Ω	1,099Ω	1,102Ω	21.1°C
80°F	1,104Ω	1,106Ω	1,108Ω	1,110Ω	1,112Ω	1,115Ω	1,117Ω	1,119Ω	1,121Ω	1,123Ω	26.7°C
90°F	1,125Ω	1,127Ω	1,130Ω	1,132Ω	1,134Ω	1,136Ω	1,138Ω	1,140Ω	1,143Ω	1,145Ω	32.2°C
100°F	1,147Ω	1,149Ω	1,151Ω	1,153Ω	1,155Ω	1,158Ω	1,160Ω	1,162Ω	1,164Ω	1,166Ω	37.8°C
110°F	1,168Ω	1,170Ω	1,173Ω	1,175Ω	1,177Ω	1,179Ω	1,181Ω	1,183Ω	1,185Ω	1,188Ω	43.3°C
120°F	1,190Ω	1,192Ω	1,194Ω	1,196Ω	1,198Ω	1,200Ω	1,203Ω	1,205Ω	1,207Ω	1,209Ω	48.9°C
130°F	1,211Ω	1,213Ω	1,215Ω	1,217Ω	1,220Ω	1,222Ω	1,224Ω	1,226Ω	1,228Ω	1,230Ω	54.4°C
140°F	1,232Ω	1,235Ω	1,237Ω	1,239Ω	1,241Ω	1,243Ω	1,245Ω	1,247Ω	1,249Ω	1,252Ω	60.0°C
150°F	1,254Ω	1,256Ω	1,258Ω	1,260Ω	1,262Ω	1,264Ω	1,266Ω	1,269Ω	1,271Ω	1,273Ω	65.6°C
160°F	1,275Ω	1,277Ω	1,279Ω	1,281Ω	1,283Ω	1,286Ω	1,288Ω	1,290Ω	1,292Ω	1,294Ω	71.1°C
170°F	1,296Ω	1,298Ω	1,300Ω	1,303Ω	1,305Ω	1,307Ω	1,309Ω	1,311Ω	1,313Ω	1,315Ω	76.7°C
180°F	1,317Ω	1,320Ω	1,322Ω	1,324Ω	1,326Ω	1,328Ω	1,330Ω	1,332Ω	1,334Ω	1,336Ω	82.2°C
190°F	1,339Ω	1,341Ω	1,343Ω	1,345Ω	1,347Ω	1,349Ω	1,351Ω	1,353Ω	1,355Ω	1,358Ω	87.8°C
200°F	1,360Ω	1,362Ω	1,364Ω	1,366Ω	1,368Ω	1,370Ω	1,372Ω	1,374Ω	1,377Ω	1,379Ω	93.3°C
210°F	1,381Ω	1,383Ω	1,385Ω	1,387Ω	1,389Ω	1,391Ω	1,393Ω	1,396Ω	1,398Ω	1,400Ω	98.9°C
220°F	1,402Ω	1,404Ω	1,406Ω	1,408Ω	1,410Ω	1,412Ω	1,414Ω	1,417Ω	1,419Ω	1,421Ω	104.4°C
230°F	1,423Ω	1,425Ω	1,427Ω	1,429Ω	1,431Ω	1,433Ω	1,435Ω	1,438Ω	1,440Ω	1,442Ω	110.0°C
240°F	1,444Ω	1,446Ω	1,448Ω	1,450Ω	1,452Ω	1,454Ω	1,456Ω	1,459Ω	1,461Ω	1,463Ω	115.6°C
250°F	1,465Ω	1,467Ω	1,469Ω	1,471Ω	1,473Ω	1,475Ω	1,477Ω	1,479Ω	1,482Ω	1,484Ω	121.1°C
260°F	1,486Ω	1,488Ω	1,490Ω	1,492Ω	1,494Ω	1,496Ω	1,498Ω	1,500Ω	1,502Ω	1,505Ω	126.7°C
270°F	1,507Ω	1,509Ω	1,511Ω	1,513Ω	1,515Ω	1,517Ω	1,519Ω	1,521Ω	1,523Ω	1,525Ω	132.2°C
280°F	1,527Ω	1,530Ω	1,532Ω	1,534Ω	1,536Ω	1,538Ω	1,540Ω	1,542Ω	1,544Ω	1,546Ω	137.8°C
290°F	1,548Ω	1,550Ω	1,552Ω	1,555Ω	1,557Ω	1,559Ω	1,561Ω	1,563Ω	1,565Ω	1,567Ω	143.3°C
300°F	1,569Ω	1,571Ω	1,573Ω	1,575Ω	1,577Ω	1,579Ω	1,582Ω	1,584Ω	1,586Ω	1,588Ω	148.9°C

# Replacing RTDs



## WARNING: Hot Surfaces

Allow the RQT Premium to cool to below 100°F {38°C} before servicing the unit.



**NOTE:** Refer to the “Zero Energy State (ZES)” Section of this manual for more “Lock Out Turn Off” information.

### To replace an RTD:

- 1 Disconnect and lockout the main power.**
- 2 Drain the unit of all water** through the drain plug in the rear of the unit. Refer to “To shut down the unit to change water hookups or perform maintenance” earlier in the Operation section of this User Guide.
- 3 Remove the unit’s top panel and open the electrical enclosure.** See section “Accessing the RQT Premium Enclosure” in the Maintenance section of this User Guide.
- 4 Remove the side panels.** See section “Accessing the RQT Premium Enclosure” in the Maintenance section of this User Guide.
- 5 Remove the RTD.** Loosen the compression nut to slide the RTD out of the casing. Disconnect the RTD wires at the terminal strip. Note locations of wires before disconnecting. Remove wire ties.
- 6 Install the new RTD.** Insert the tip of the new RTD at least 1 inch into the tank, attempting to locate the tip of the RTD in the center of the fluid stream. Tighten the compression nut. Thread the leads through the raceway leading to the electrical enclosure.
- 7 Re-secure RTD wires to the various wire mounts** to keep the wire from contacting the heater housing, pump casing, or motor housing. Wire the RTD wires to secure them within the electrical cabinet.
- 8 Do not trim off the extra wire. Leave it coiled like the the original RTD so as to not influence circuit resistance. Strip and attach RTD leads to the terminal strip at locations noted in step 4.** Polarity does not matter.

**IMPORTANT:** Always refer to the wiring diagrams that came with your RQT Premium to locate specific electrical components. Illustrations in the User Guide are intended to be representative only.

**NOTE:** You may want to test the resistance of the new RTD to ensure it aligns with the table in the previous section.

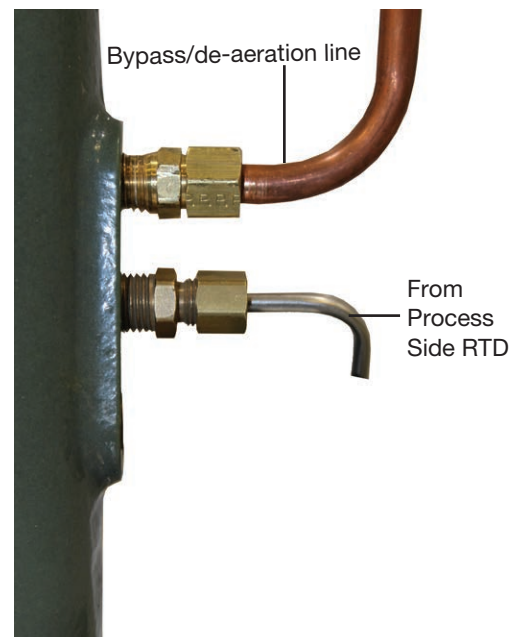
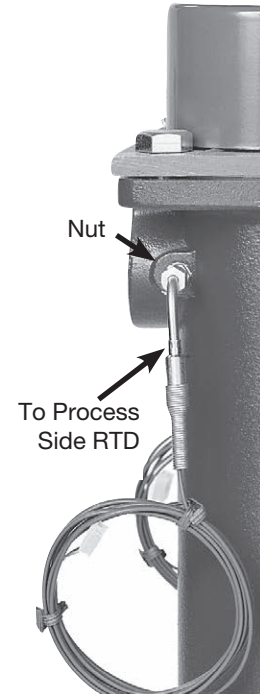

# Repairing Cooling Valves

Every RQT Premium has a valve assembly that controls the cooling water out flow. Occasionally, this valve assembly may need to be cleaned, if clogged with debris, or replaced. The steps below details these procedure.



## **WARNING: Electrical Shock and Hot Surface Hazard**



Before attempting maintenance of any kind on the RQT Premium, you must stop the unit; disconnect and lockout the main power supply; and allow the unit to cool to 100°F {38°C}.



**NOTE:** Always refer to the connection diagram sticker on the back of your machine for proper connection locations.”  
Each unit now has a connection diagram sticker (like this one) that shows where connections are made on the back of the unit.

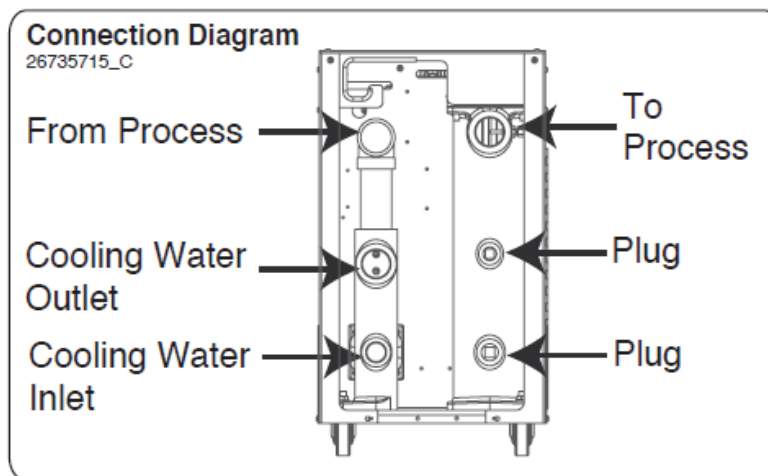

This configuration is used for units up to 18kW.



**NOTE:** Sample illustration - may not reflect your RQT Premium configuration. Refer to the label that is applied to your machine.

- 1 Disconnect all energy sources including cooling water in, electrical power, and compressed air.** Refer to the *Zero Energy State* information in the *Installation* section of this User Guide.
- 2 Drain the unit of all water** through the drain plug in the rear of the unit. Refer to “*To shut down the unit to change water hookups or perform maintenance*” earlier in the *Operation* section of this User Guide.
- 3 Observe and record the existing orientation of the valve, its actuator, and override handle** so that it can be re-installed in the identical orientation.
- 4 Remove the connections to the cooling water out.**
- 5 Remove the valve from the cooling water out line.**
- 6 Disassemble the valve.**
- 7 Inspect and clean or repair the valve body assembly.** Remove foreign particles and replace damaged parts as necessary.
- 8 Reassemble the valve and other components.** Reassemble in reverse order. Seal all pipe fittings with pipe sealant. Check that all flows are in the correct direction. Check for leaks before resuming operation.

# Replacing Immersion Heaters



## **WARNING: Electrical Shock and Hot Surface Hazard**



Before attempting maintenance of any kind on the RQT Premium, you must stop the unit; disconnect and lockout the main power supply; and allow the unit to cool to 100°F {38°C}.



- 1 Disconnect all energy sources including cooling water in, electrical power, and compressed air.**

*Refer to the “Zero Energy State (ZES)” information in the installation section of this User Guide.*

- 2 Remove the top panel of the RQT Premium.**

Rotate heater cap if necessary for proper knockout position. *See section “Accessing the RQT Premium Enclosure.”*

- 3 Remove the heater cap.** Use a Phillips screwdriver to remove the heater connection box lid.

- 4 Remove the heater wiring harness.** Label the wiring layout of the heater terminals; wires are labeled as 2T1, 2T2, 2T3 and GND. (They may also be labelled as 3T1, 3T2, 3T3 if dual-fed or 48kw units)

Record the position of bus links, jumpers, and feed wires so they can be replaced in exactly the same manner on the replacement heater.

Then unscrew the nuts on the cable connectors and remove the wires.

- 5 Drain the RQT Premium.** *Refer to “To shut down the unit to change water hookups or perform maintenance” earlier in the Operation section of this User Guide.*

- 6 Remove the four bolts that hold the heater element in place.** Use a 9/16-inch socket.

- 7 If heater feed wires terminate in hexagonal termination studs, remove those studs from the heater with a nut driver and re-install on the replacement heater.**

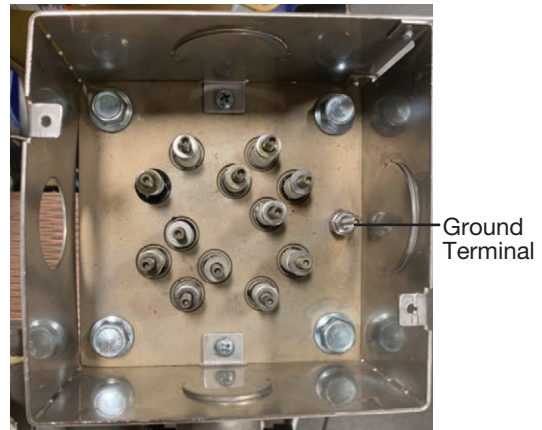
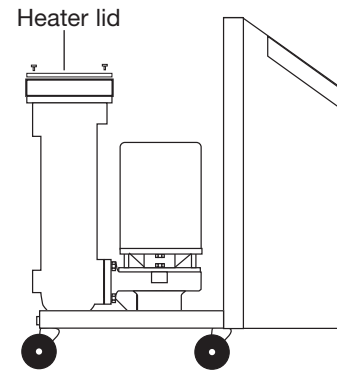

Heater on the TCU Showing Hexagonal Terminal Studs

(Continued)

## Replacing Immersion Heaters (Continued)

- 8 To Re-install add-on heater termination stud use a nut driver and use the same torque you would use to tighten the standard stud nut. **Do not overtighten!**

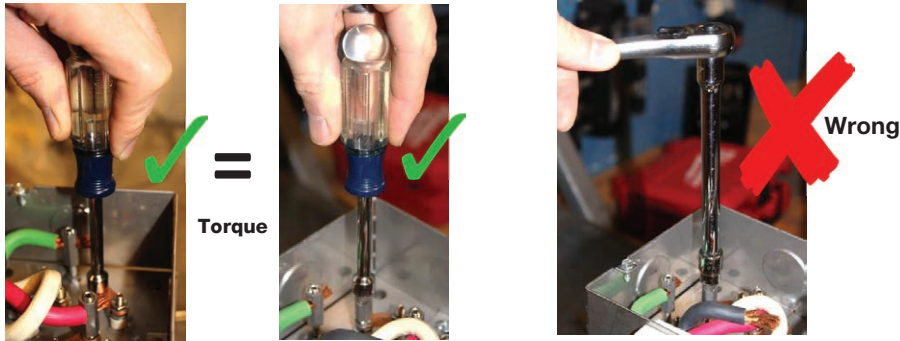

- 9 When tightening the set screw, be sure to use a backer wrench on the add-on termination stud.

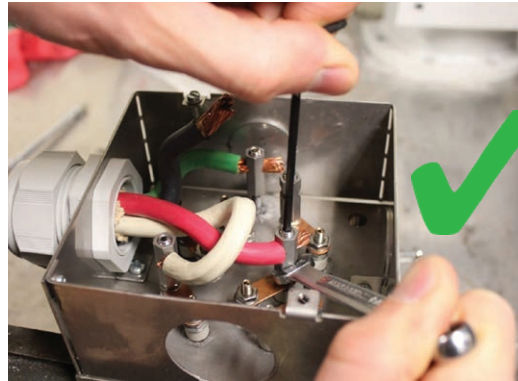

- 10 Copper conductors should protrude 1/8" to 3/8" beyond the exit from the add-on heater stud, being careful to not approach a stud of an opposing phase or grounded surface.

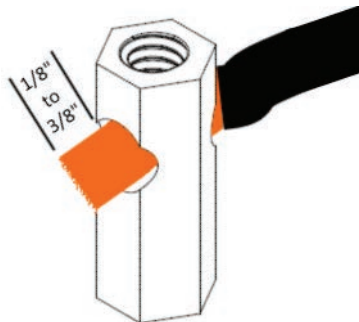

# Replacing Immersion Heaters (Continued)

## Parts

	Description	Usage
	Small Add-On Heater Termination Stud	For #8 & #6 wires.
	Medium Add-On Heater Termination Stud	For #4 wires.

## Wire gauge vs. kW vs Voltage reference:

HEATER: 460VAC				
kW	FLA	FLEX CORD	ADD-ON TERMINATIONS?	FEED
9	11.3	#14/4	No	Single
12	15.1	#12/4	No	Single
18	22.6	#8/4	Yes-Small 3350240701, x4	Single
24	30.1	#6/4	Yes-Small 3350240701, x4	Single
36	45.2	#4/4	Yes-Medium 3350240702, x4	Single
HEATER: 208-230VAC				
kW	FLA	FLEX CORD	ADD-ON TERMINATIONS?	FEED
9	22.6	#8/4	Yes-Small 3350240701, x4	Single
12	30.1	#6/4	Yes-Small 3350240701, x4	Single
18	45.2	#4/4	Yes-Medium 3350240702, x4	Single
24	60.2	#6/4	Yes-Small 3350240701, x7	Dual
36	90.4	#4/4	Yes-Medium 3350240702, x7	Dual
HEATER: 575VAC				
kW	FLA	FLEX CORD	ADD-ON TERMINATIONS?	FEED
9	9.0	#14/4	No	Single
12	12.0	#12/4	No	Single
18	18.1	#10/4	No	Single
24	24.1	#8/4	Yes-Small 3350240701, x4	Single
36	36.1	#4/4	Yes-Medium 3350240702, x4	Single
HEATER: 380-400VAC				
kW	FLA	FLEX CORD	ADD-ON TERMINATIONS?	FEED
9	13.0	#12/4	No	Single
12	17.3	#10/4	No	Single
18	26.0	#8/4	Yes-Small 3350240701, x4	Single
24	34.6	#4/4	Yes-Medium 3350240702, x4	Single
36	48.2	#8/4	Yes-Small 3350240701, x7	Dual

(Continued)



## Replacing Immersion Heaters (Continued)

**11** Lift the heating element out of the heater tank. Lift the element straight up.

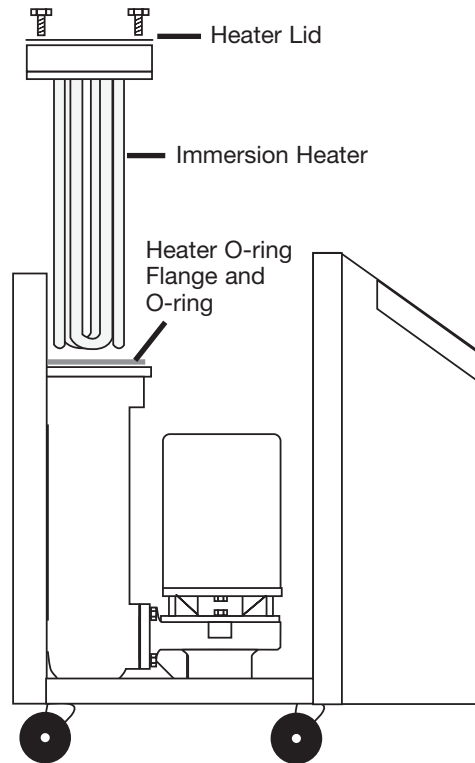

**12** Clean the heater tank. Remove any rust or solids that may have built up before inserting the heater elements.

**13** Replace the heater O-ring if it is worn or cracked.

**14** Clean the O-ring flange or replace it.

**15** Reverse these steps to install the new heater element and reassemble the unit.

**IMPORTANT:** Note heater orientation - grounding bolt location is crucial to proper operation. Heater ground should be at the back of unit. Heater orientation should be such that the ground is located at the rearmost portion of the RQT Premium (opposite the open knockout of the electrical box).

# Removing the Pump



## **WARNING: Electrical Shock and Hot Surface Hazard**



Before attempting maintenance of any kind on the RQT Premium, you must stop the unit; disconnect and lockout the main power supply; and allow the unit to cool to 100°F {38°C}.



**NOTE:** Refer to the “Zero Energy State (ZES)” Section of this User Guide for more information.

- 1 Disconnect and lockout the main power. Disconnect and lockout compressed air (if equipped).**
- 2 Shut off the cooling water in feed.**
- 3 Drain the unit of all fluid.** Remove the drain plug at the rear of the unit.
- 4 Remove the top and side panels of the RQT Premium.** See section “Accessing the RQT Premium Enclosure.”
- 5 Remove the pump assembly bolts.** Use a 9/16-inch open-end box wrench to remove the bolts holding the pump to the pump casing. The bolt in the rear will require a 9/16-inch socket wrench.
- 6 Lift the pump assembly straight up to remove.** The pump can now be replaced or disassembled for repair.
- 7 Reverse the steps to reassemble the unit.**



**NOTE:** Before restarting, reprime the pump. Do not start until the pump is completely filled with water.

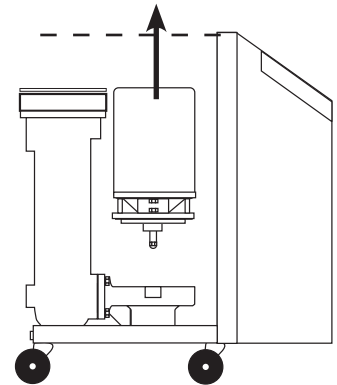

# Timecode Retrieval Procedure

In the event of accidental or incorrect programming of the machine configuration during initial set-up, the RQT Premium controller, in coordination with Thermal Care Customer Service, can be elevated back to factory level security access to allow modifications to machine configuration. To do so, follow the steps shown below.

**1 From the Main Menu, tap on the “User” icon.**

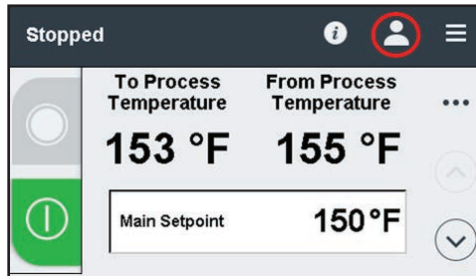

**2 Tap on the “Timecode” tab shown below.**

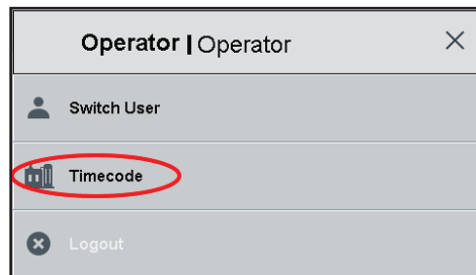

**3 Retrieve the Timecode values and submit the code to Thermal Care Customer Service.** Service will provide a unique password, which will allow access back to factory levels.

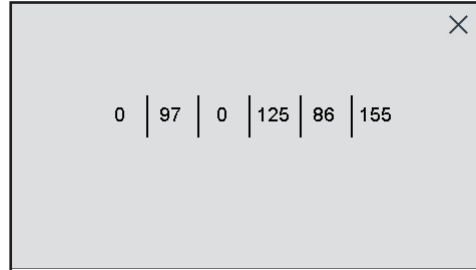

**4 The password can then be entered by going back to the “User” icon**

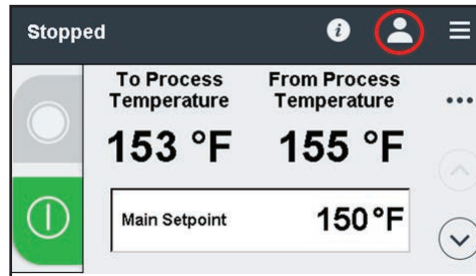

**5 Tap on “Switch User”**

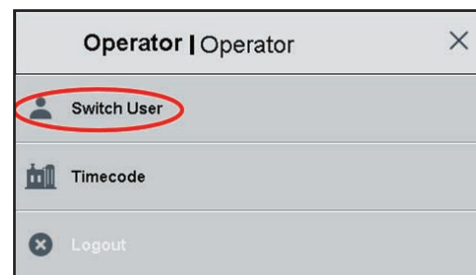

(Continued)

## Timecode Retrieval Procedure (Continued)

- 6** You will be prompted with the screen shown to the right where you can enter the password that was generated from Thermal Care Customer Service by the timecode that was submitted earlier.



- 7** This will elevate the RQT Premium controller back to Factory permissions, which can be confirmed on the controller by the factory icon replacing the user icon in the upper right hand corner.

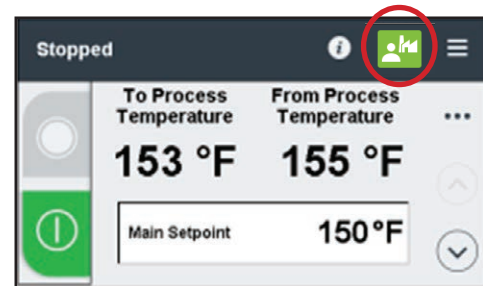
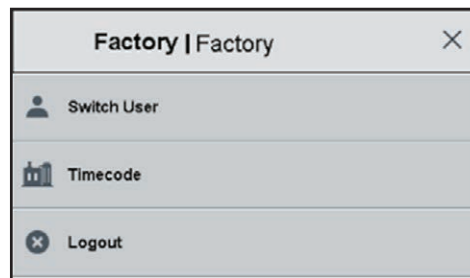

# Appendix A

---

## We're Here to Help

Thermal Care has made a large investment in customer support. Our service experts are available to help with any problem you might have installing and operating your equipment. Your Thermal Care sales representative also can help analyze the nature of your problem, assuring that it did not result from misapplication or improper use.

## How to Contact Customer Service

To contact Customer Service:

Phone: 847-966-2636

Email: [tcservice@thermalcare.com](mailto:tcservice@thermalcare.com)

To contact Parts:

Phone: 847-966-8560

Email: [tcparts@thermalcare.com](mailto:tcparts@thermalcare.com)



**NOTE:** Normal operating hours are 8:00 am - 5:00 pm CST. After hours emergency service is available at the same phone number.

## Before You Call...

**If you do have a problem, please complete the following checklist before calling Thermal Care:**

- Make sure you have all model, control type from the serial tag, and parts list numbers for your particular equipment. Service personnel will need this information to assist you.
- Make sure power is supplied to the equipment.
- Make sure that all connectors and wires within and between control systems and related components have been installed correctly.
- Check the troubleshooting guide of this manual for a solution.
- Thoroughly examine the instruction manual(s) for associated equipment, especially controls. Each manual may have its own troubleshooting guide to help you.



# Appendix B

---

## PID Parameters

The Thermal Care RQT Premium features a PID (“proportional-integral-derivative”) control-loop algorithm implemented in the programming of the controller board. This algorithm is used to achieve the proper temperature of the process fluid quickly and accurately. The following tables and paragraphs describe its operation.

The default factory PID parameters loaded into the unit should work well under most applications. However, due to a wide variety of situations and system requirements, these parameters can be adjusted to best serve a particular application.

PID Default Parameters		
Controller Parameter	Default	Comments
PID P - Band	7	<i>Smaller</i> number = more aggressive proportional cooling response.
PID I - Gain	25	<i>Smaller</i> number = more aggressive integral cooling response.
PID D - Gain	10	<i>Larger</i> number = more aggressive derivative cooling response.
Integral Active Band	15	Integral Active Band defines the band over which the integral response is active. Typically set similar as the proportional band to prevent excessive integral windup.

### Proportional

The main driver for the RQT Premium control loop is the proportional response. Proportional logic is very simple—it selects a heating or cooling level (strength) based on how close the process temperature is to the setpoint.

The proportional parameter defines a band over what range of degrees the temperature controller will taper-off its heating or cooling. Heating/Cooling will be applied at 100% if the process temperature is more than the band parameter away from the setpoint. A smaller number will produce a more aggressive proportional response because it will shrink the band.

If the RQT Premium is not providing a strong enough heating or cooling response for a given situation, this parameter number should be made more aggressive (a smaller number should be used).

# PID Parameters (Continued)

## Integral

Using only proportional control will cause the RQT Premium to have steady-state error (it will never exactly reach setpoint). Integral response is used to eliminate this undesirable condition.

Integral logic introduces the awareness of the passage of time into the logic by looking into the past—and observing how far the process has been from the setpoint over time. The farther away the process is from setpoint for a longer time, the more it causes the RQT Premium to produce a stronger counter-response. Integral action is internally disabled whenever the RQT Premium is further from setpoint than the Integral Active Band because it has no merit under this condition.

A smaller number will produce a more aggressive integral response. However, “0” will completely turn off integral response.

If the process temperature is approaching the setpoint too slowly, a stronger integral response (a smaller parameter number) can be used to remedy the situation. Too much integral response can cause the RQT Premium temperature to severely oscillate. Typical values would range from 10 to 400.

## Derivative

Derivative response is used to eliminate overshoot. It is also used to compensate for the slow-responding modulating valve. Like integral logic, it is aware of the passage of time—it looks forward into the future and anticipates if the machine will be overshooting the setpoint at some point in the future, based on current trends.

Derivative action is disabled whenever the RQT Premium is far (further than twice the proportional band) from the setpoint.

A larger number will produce a more aggressive derivative response. If the system temperature is overshooting the setpoint, try a more aggressive derivative response. If the system stutters or temporarily reverses temperature direction as approaching setpoint, your derivative response is too aggressive. If overshoot is not a concern, or you have a very large system, derivative control can be completely turned off by setting the parameter to “0” without negative consequences.

## Manual Tuning Procedure

If you find yourself in a situation where the RQT Premium is responding in an unpredictable manner, follow the procedure below to simplify the control loop and pick appropriate PID parameters.

### PREREQUISITES:

- Your cooling water must be at a reasonably stable temperature and pressure.*
- Your external heat load on the RQT Premium must be reasonably constant.*
- Select a setpoint for tuning that is similar to a typical setpoint for the process.*
- You must have sufficient time to run your system through several thermal cycles in order to perform a full tuning.*



# PID Parameters (Continued)

## STEPS:

### Run a Test - Proportional

**1** Start the RQT Premium and observe it attempting to reach setpoint.

**2** To access the screen to modify the PID band parameters, go to the Hamburger → Configuration → Setup menu and scroll right (>) until you reach the Control Loop Menu.

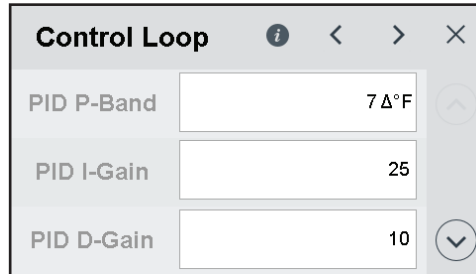

**3** Set I-gain and D-gain both to 0 so that only P-Band is active.

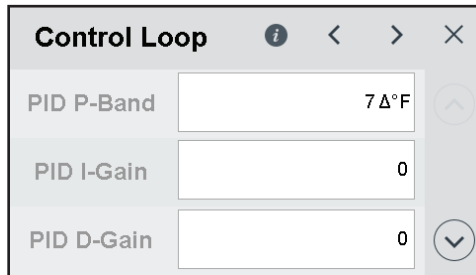

**4** Decrease the PID - P Band until the system begins to oscillate around the setpoint. The PID P-Band is the temperature band over which the PID proportional response will be 100%. A smaller value produces a more aggressive PID proportional response. Example: if set to “5”, the unit will provide 100% cooling/heating response when 5 degrees away from setpoint.

 **NOTE:** You may have to cool down your system and repeat the experiment several times so you can accurately observe the process temperature approaching setpoint.

**5** Multiply the value determined by Step 4 by “2” and enter it as the new P-Band.

**6** Observe how closely the process value lags the setpoint in steady state. If it is close enough, no integral gain is needed and you may skip to the derivative testing section, Step 9. Otherwise, remember this lagging observation for the next section and continue to the next step.

### Continue the Test – Proportional + Integral

**7** Integral Active Band defines the band over which the integral response is active. This is typically set to a similar value as the proportional band to prevent excessive integral windup, but can be altered if desired.

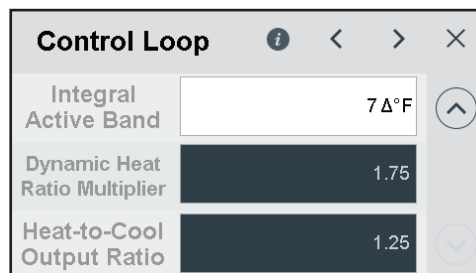

(Continued)

## PID Parameters (Continued)

- 8** Next, add in PID I-Gain for the PID controller. A default value of “25” is a reasonable starting point. A smaller number will produce a more aggressive integral response to eliminate steady state lagging error (however Zero will fully disable all integral response). This number should be small enough so that the process value exactly tracks the setpoint in steady state over time, but not so small that the system oscillates in steady state.

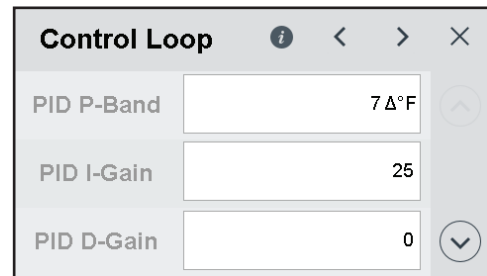

### Continue the Test – Proportional + Integral + Derivative

- 9** Cool down your system and repeat the experiment so you can truly observe the process temperature approaching setpoint. You will probably observe the temperature overshooting the setpoint. If overshoot is acceptable for your process, there is no reason to continue tuning and you may leave PID D-Gain disabled at zero. If you would like to eliminate overshoot in exchange for slightly longer times until setpoint is reached, overshoot can be eliminated using the next step.
- 10** Set the D-Gain to “10”. Run the system through a thermal cycle and observe the overshoot the first time it reaches setpoint.

- 11** Double the PID D-Gain and run the machine through another thermal cycle. If you have a modulating valve, you may wish to observe its position, since derivative control will also help the system properly anticipate the slow operating time for such a valve.

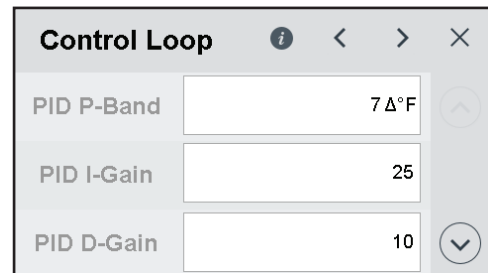

- 12** Repeat the doubling process of this parameter until overshoot is satisfactorily eliminated. If the system stutters or temporarily reverses temperature direction as approaching setpoint, your derivative response is too aggressive and you need to decrease this parameter.

### Finished

- 13** You should review your work and make sure your system is not on the verge of oscillating. If your system oscillates intermittently, you probably have your gains too aggressive. It is better to be mild in your tuning than over-aggressive.
- 14** You are now finished tuning your system. Be sure to record your parameters PID B-Band, PID I-Gain, PID D-Gain, and Integral Active Band. The parameters may need to be tweaked if your system or setpoint changes significantly.



# Plumbing Diagrams (Continued)

## Closed-circuit common-source

In a closed-circuit common-source arrangement, the cooling fluid mixes with the process fluid only at initial filling. After that, there is very limited interaction of process and cooling water, and the cooling function is achieved by transferring heat through a heat exchanger. The immersion heater provides heat directly into the process fluid whenever needed.

### CLOSED-CIRCUIT COMMON-SOURCE RQT PREMIUM

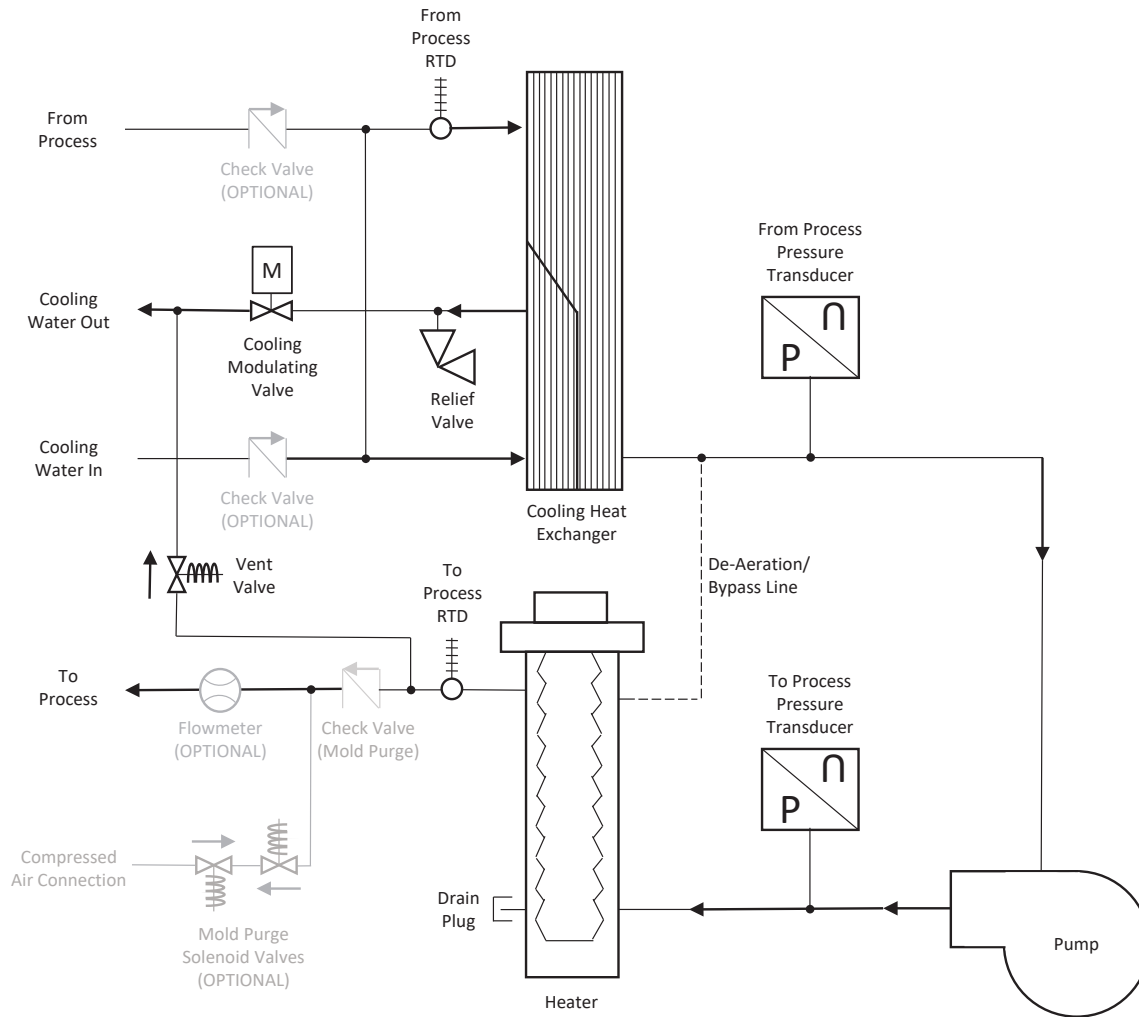

In this configuration process and cooling fluids mix only at filling.

Fill line is used for both pressurization and expansion of process fluid (causes limited interaction of process and cooling water).

# Plumbing Diagrams (Continued)

## Closed-circuit separate-source

In a closed-circuit separate-source arrangement, the cooling fluid never mixes with the process fluid. All cooling is achieved by transferring heat through a heat exchanger. The immersion heater provides heat directly into the process fluid whenever needed. Provisions must be provided for filling the process loop, and venting the process to eliminate air and accommodate thermal fluid expansion.

### CLOSED-CIRCUIT SEPARATE-SOURCE RQT PREMIUM

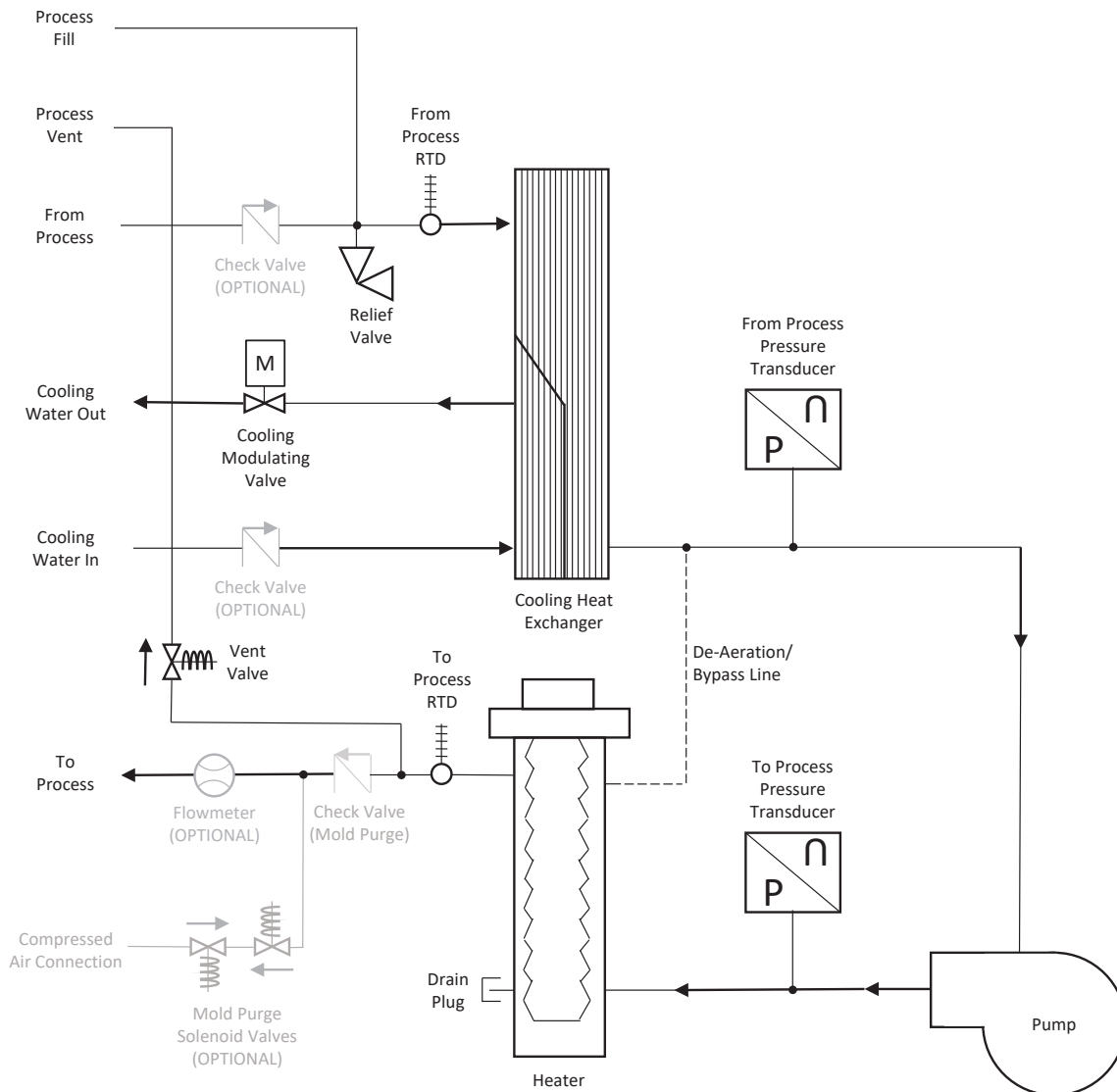



# Plumbing Diagrams (Continued)

**Closed-circuit common-source** - In a closed-circuit common-source arrangement, the cooling fluid mixes with the process fluid only at initial filling. After that, there is very limited interaction of process and cooling water, and the cooling function is achieved by transferring heat through a heat exchanger. The immersion heater provides heat directly into the process fluid whenever needed.

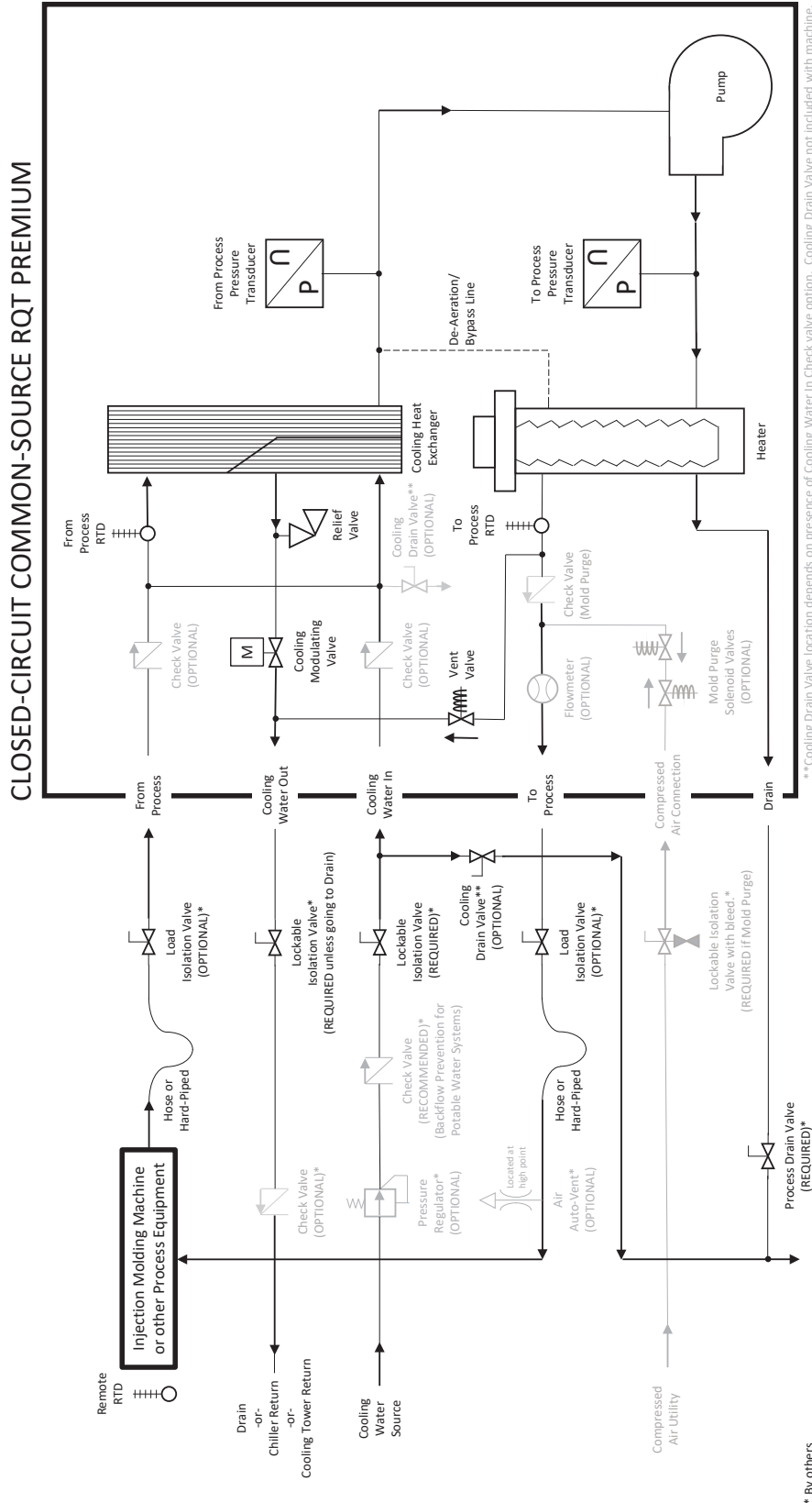

Revised 7-11-22

\* By others

# Plumbing Diagrams (Continued)

**Closed-circuit separate-source** - In a closed-circuit separate-source arrangement, the cooling fluid never mixes with the process fluid. All cooling is achieved by transferring heat through a heat exchanger. The immersion heater provides heat directly into the process fluid whenever needed. Provisions must be provided for filling the process loop, and venting the process to eliminate air and accommodate thermal fluid expansion.

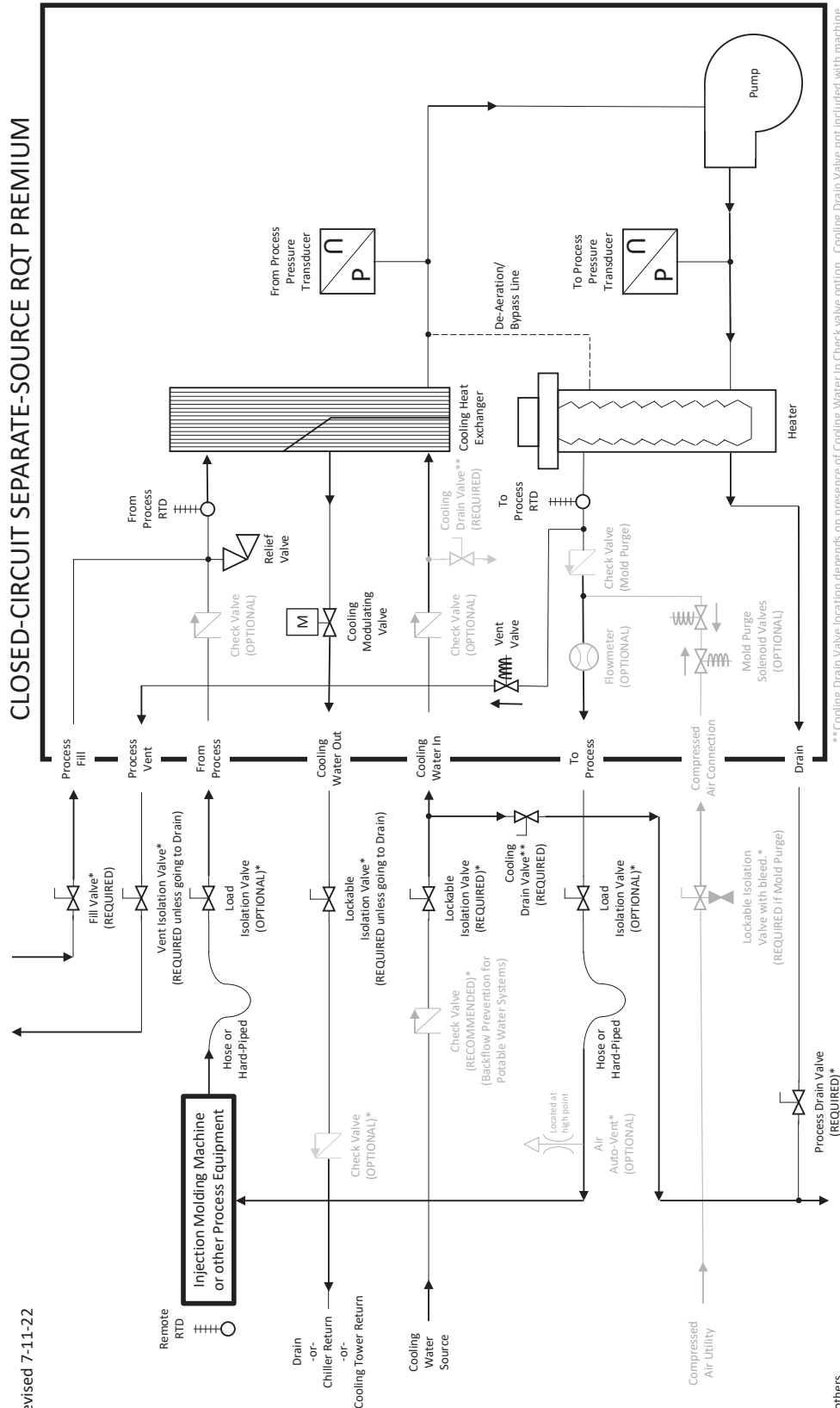

CLOSED-CIRCUIT SEPARATE-SOURCE RQT PREMIUM

Revised 7-11-22

\* By others



# Plumbing Curves

## Direct Injection

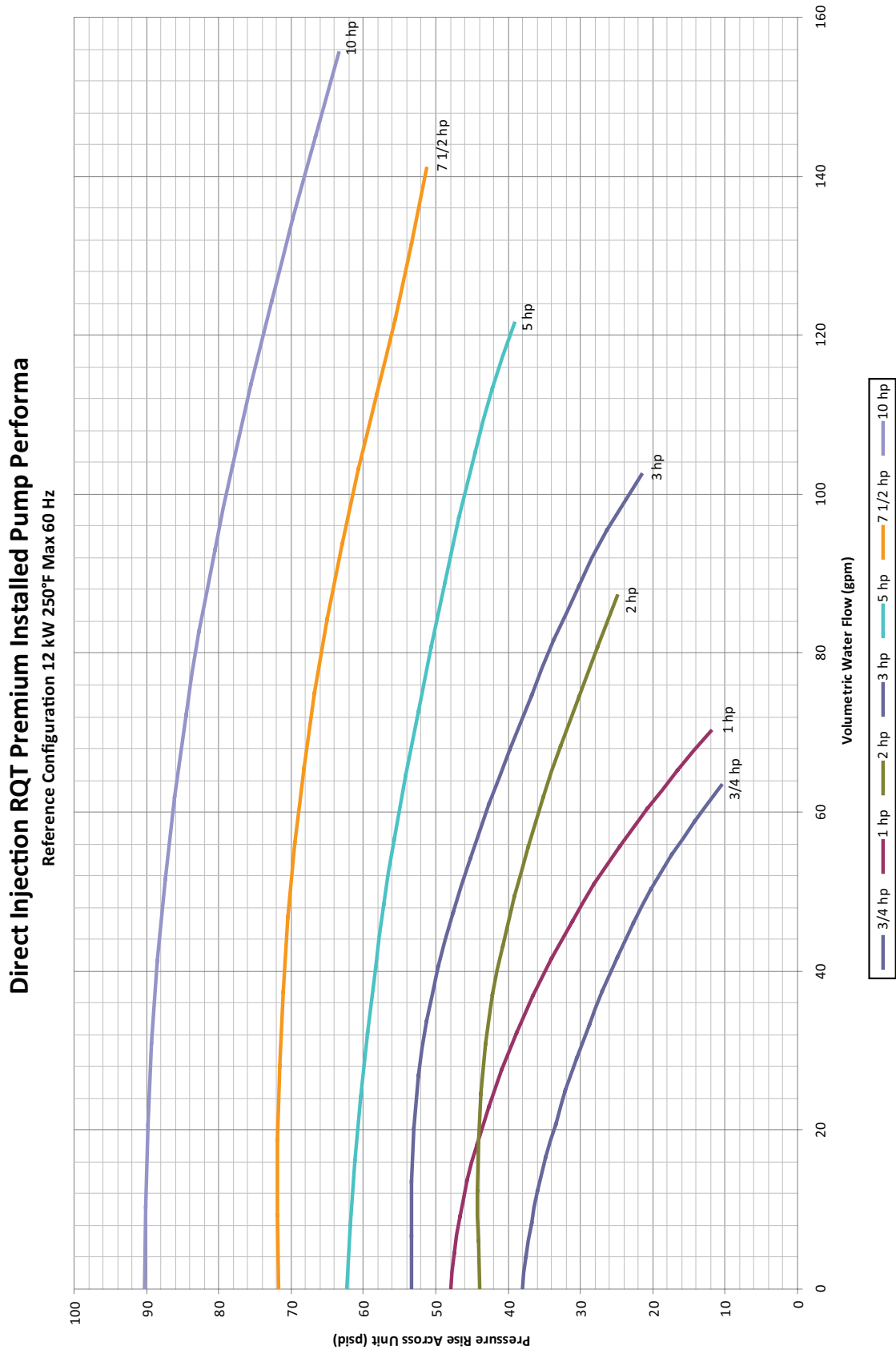

# Plumbing Curves (Continued)

Closed Circuit Standard Performance

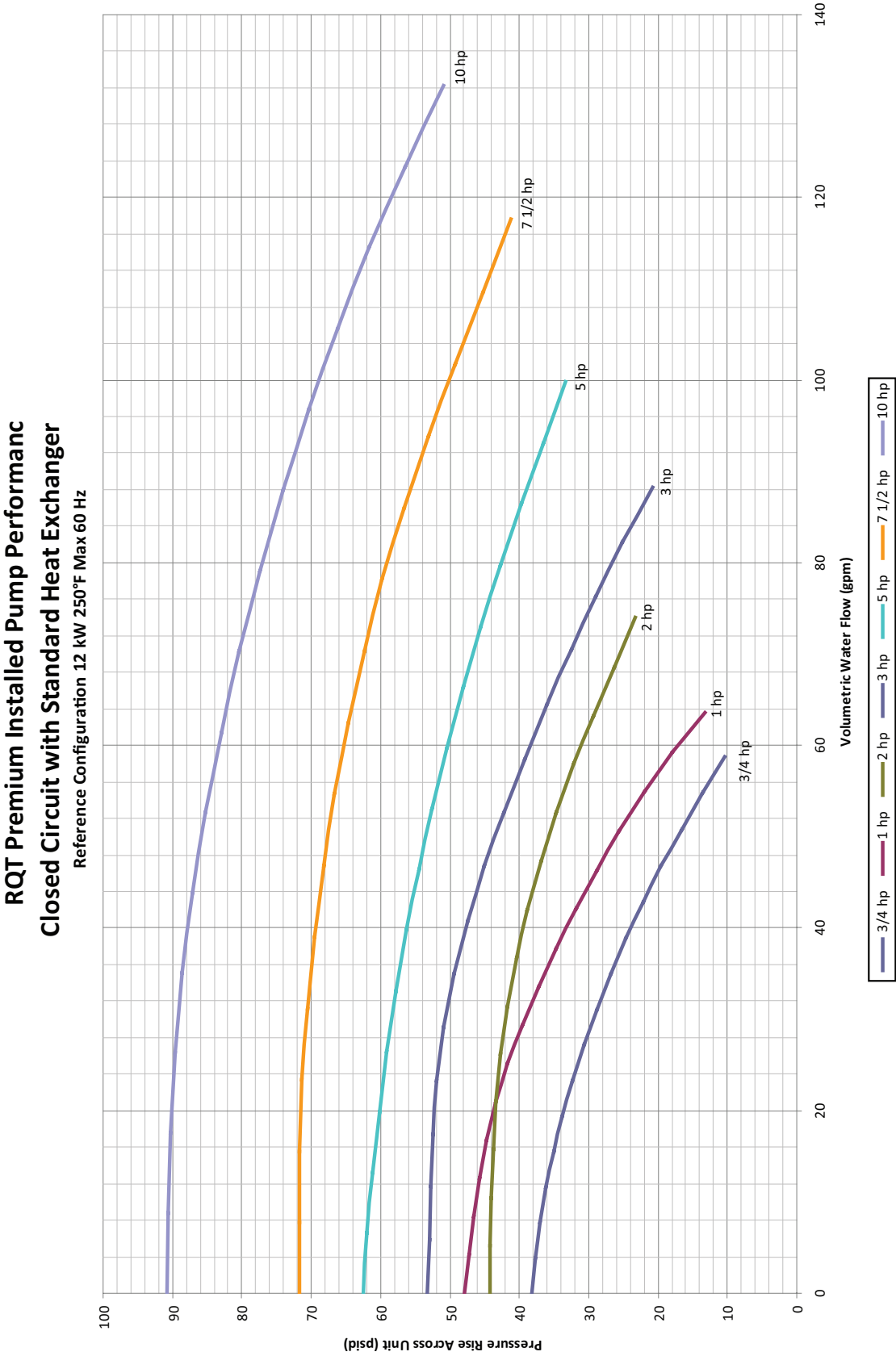

# Appendix D

## External Interfaces

### Process Temp Retransmit / Analog Remote Setpoint

#### Connecting to the RQT Premium

 **WARNING: Improper installation, operation, or servicing may result in equipment damage or personal injury.**



External analog signals must be fully isolated from ground. Be sure to use fully isolated analog channels and/or power supplies. Analog wires must not be common or referenced to earth ground! Failure to heed this requirement will permanently damage the analog circuits in the TCU.

#### Process Temperature Retransmit

For Process Temperature Retransmit, see electrical prints for wiring of this feature to the analog output on slot 4 of the controller. Current (4-20mA) or voltage (0-10VDC) signals may be used per the associated hookup shown on the prints, just not simultaneously. The software settings must match the chosen physical signal type, as determined on the Misc Options menu (Hamburger→Configuration→Component Configuration→6x “>”).

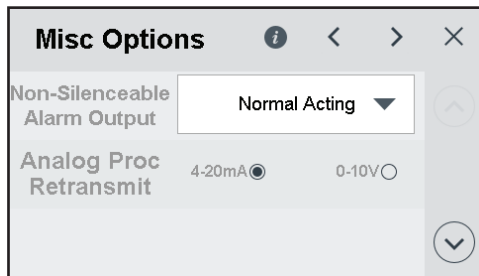

You can scale/calibrate the signal as you see fit on the next screen by pressing the down arrow.

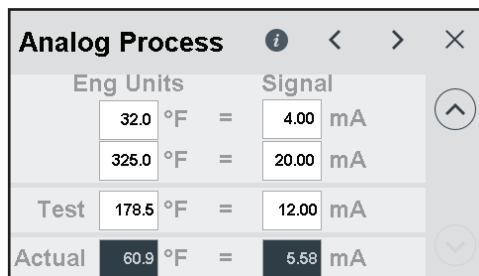

## External Interfaces (Continued)

### Analog Remote Setpoint

For Analog Remote Setpoint, see electrical prints for wiring of this option to the analog input on slot 7 of the controller. Current (4-20mA) or voltage (0-10VDC) signals may be used per the associated hookup shown on the prints, just not simultaneously. The software settings must match the chosen physical signal type, as determined on the Remote Analog Setpoint menu.

(Hamburger→Configuration→Component Configuration→ 5x “>”)

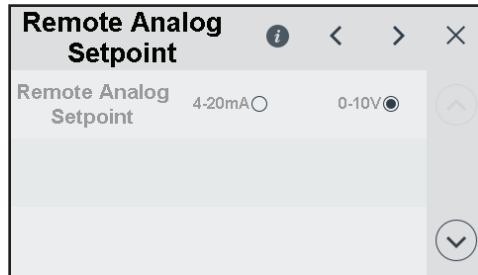

You can scale/calibrate the signal as you see fit on the next screen by pressing the down arrow.

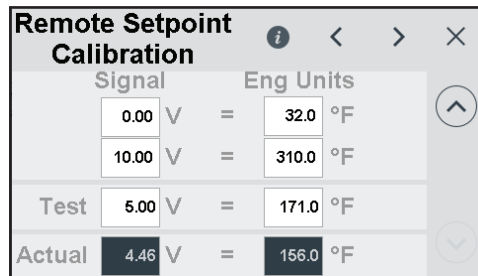

### Ethernet for Modbus-TCP and OPC-UA

The default IP address is 10.1.140.2 with a subnet mask of 255.255.0.0.

 **NOTE:** This unit is compliant with Euromap 82.1 v1.01.

# External Interfaces (Continued)

## SPI Wiring Schematic

For further information contact Thermal Care Customer Service.

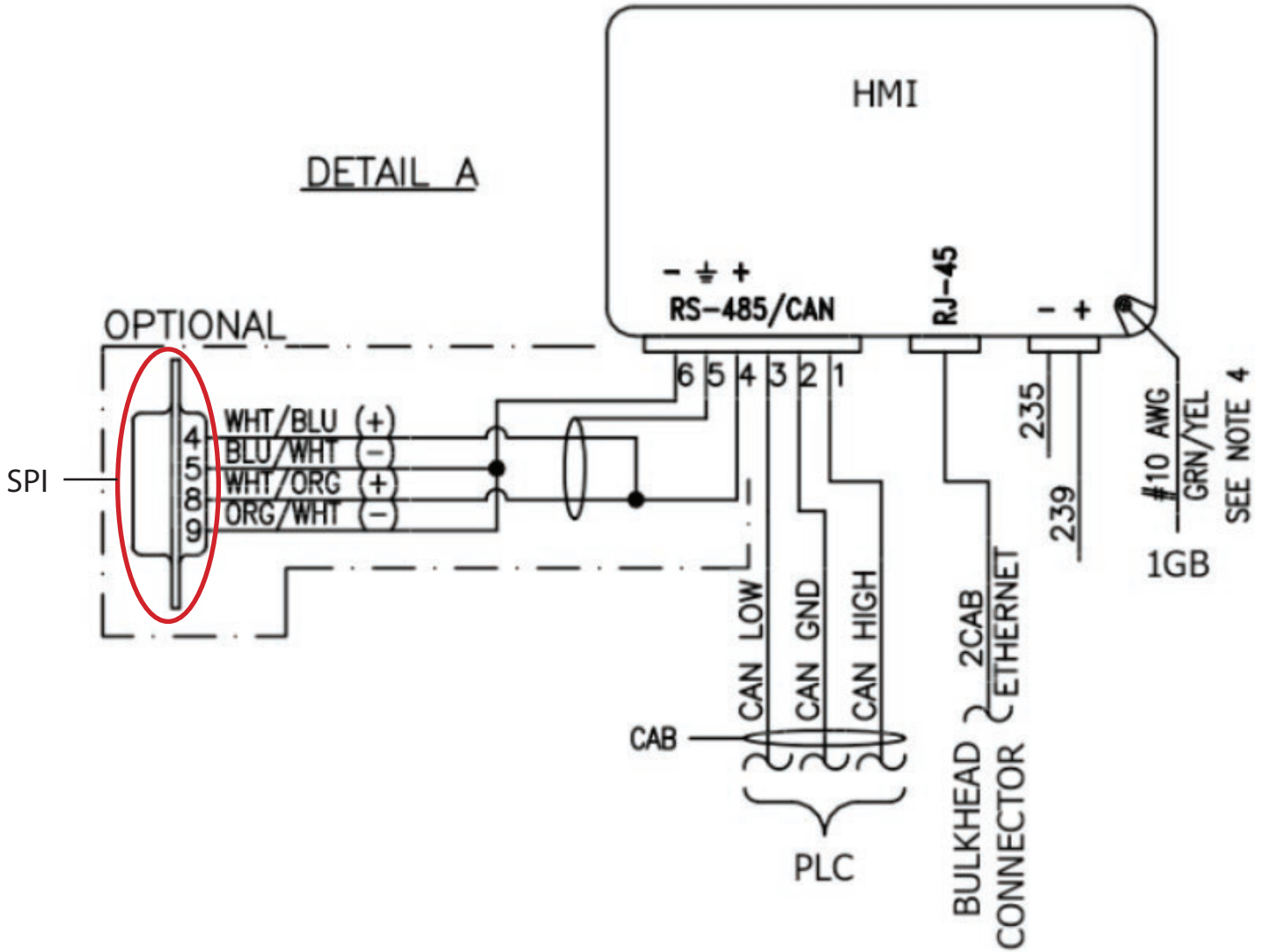

Page intentionally left blank.

# Appendix E

---

## Flowmeter Installation Instruction Sheet

PRH021-0915

- 1 Remove the plumbing connection from the unit to the process.**
- 2 Add sealant to threads and attach flowmeter and fittings to the unit according to the figure below.** The flow direction is indicated on the valve body. Make sure the meter is installed with the correct orientation.

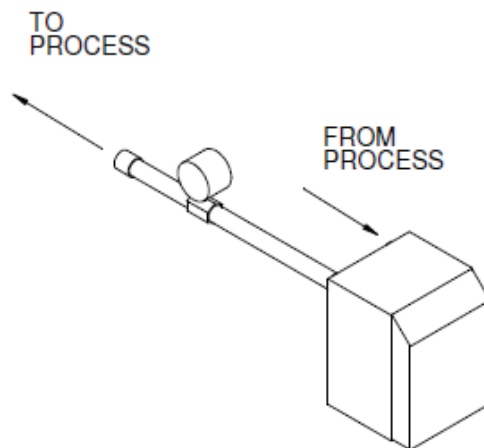

- 3 Reinstall all plumbing that was removed during installation.**
- 4 Turn water on and check for leaks. Repair as required.**
- 5 If the flowmeter has auxiliary contacts, reduce the process flow below the designated alarm threshold to test if they were set up properly.**
- 6 Wire flowmeter according to electrical prints.** Note that the wiring for pulse flowmeters will be different than analog flowmeters, but both are supported (pulse flowmeter standard, analog flowmeters as an option).

Page intentionally left blank.





5680 W. Jarvis Ave. • Niles, IL 60714  
847-966-2260  
www.thermalcare.com

**New Equipment Sales**  
847-966-2260  
sales@thermalcare.com

**Customer Service**  
847-966-2636  
tcservice@thermalcare.com

**Parts Department**  
847-966-8560 • 847-966-9358(fax)  
tcparts@thermalcare.com