

Standard Features



High-Flow Pumps

Designed to meet the rapid cooling requirements of injection mold cooling, our energy-efficient pumps provide the best flow available in the industry. Sizes from ¾ HP to 10 HP. Silicon carbide pump seals are standard.

Long-Life Heaters

Incoloy sheathed heater elements for the best combination of performance and longevity with better corrosion resistance than copper or stainless steel heaters.

Leak-Proof Pump/Heater Assembly

Heavy-duty cast-iron pumps, heater tubes, and mixing tubes with O-ring seals reduce threaded fittings that can cause internal pressure losses and are prone to leaks.

Long-Life Pump Seals/Internal Flushing System

High-temperature pump seals with an integral flush system and turbulence ribs inside the seal chamber extend seal life and are more energy efficient than external seal flush lines.

High-Performance Modulating Cooling Valves

Fast-acting modulating valve responds quickly and precisely to any sudden changes in the process and ensure consistent mold temperatures all the time.

24 VDC Control-Circuit Power

Dependable and safe control circuit power, isolates the control circuit from static interference for stable and precise operation.

Tilted Front Panel

Conveniently angled for optimal viewing, quick and easy monitoring and adjustment of the set point and other control functions.

4-20A or 0-10vDC Process Temperature Retransmit

Continuous remote monitoring of process temperature on any device.

Intelligent Air Purge with 120°F Air Purge Cancel

At start-up, the automatic air purge sequence deactivates when the mold circuit is above 120°F to avoid cooling of the mold during temporary power interruptions.

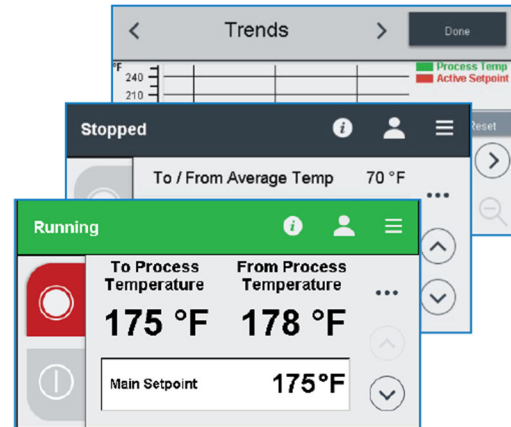

Premium Controller

Touch Screen Control

PLC control with touch screen HMI simultaneously displays two selectable operation KPIs. Easy to use HMI screens provide a visual alert of a potential problem before a fault occurs. If the condition worsens, the alarm sounds and the unit stops to prevent equipment damage. Screens include:

- Heater malfunction
- Supply and return temperature
- Pump running hours
- Power brownout
- Control power on
- Autostart signal present
- Pump on
- Pump overload
- Heat on
- Cooling on
- Low coolant inlet pressure
- High and low temperature limit warnings
- High and low temperature alarms
- Supply and return temperature probe faults
- Remote Setpoint 0-10vDC or 4-20mA

Seal-Saver

An automatic sequence cools the unit down before stopping the pump to extend pump seal life by eliminating the potential of seal warping.

Aquatherm RQT Premium Temperature Controller

Pump Running Hours Display

A quick and easy way to check on the total machine run time to better plan for routine maintenance.

Adjustable Deviation Alarm Time Delays

A programmable alarm time delay eliminates nuisance alarms at start-up by allowing the unit to reach a stable temperature before activating the temperature alarms.

Supply and Return Temperature Display

Continuous display of the set point, supply and return temperatures, for complete monitoring of the process and unit operation.

Alarm Horn and Silence Switch

Delivers an audio and visual indication of an alarm condition and silences the alarm after acknowledgement.

Electrical Phase Error

Protects against loss of phase, phase reversal, and phase imbalance.

Adaptive Maximum Setpoint

Automatically adjusts unit's maximum setpoint (up to 250°F standard and 300°F optional) for variable cooling water supply pressure installations.

Digital Process Pressure

Process and return system pressure.

Adaptive Pressure Relief

Limits pressure relief valve discharge by anticipating a pressure spike and opening the cooling valve to control system pressure.

Digital Flow Meter

Monitors flow to the mold.

Password Protection

Allows for user level security clearance passcodes.

System Statistics

Real time information on power usage, electrical enclosure temperature, alarm operations, low pressure events, cooling valve active times, pump run time, heater run time, and overall run time.

Trending Data

Historical performance data tracks variables such as supply and return temperatures, process pressure, heating and cooling percentages, and temperature accuracy.

Communication

Modbus TCP/IP & OPC/UA communications.

Alternate Setpoint Swap

Activate an alternate setpoint through a digital input.

Data Logs & Charting

Trending logs provide historical performance data tracking variables.

Recipes

Allows users to easily store detailed instructions for specific materials or applications to control process set points and alarm set points.

Available Options

Rotary Non-Fused Disconnect Switch

Provides overcurrent protection.

Mold Purge

Quickly evacuates fluid from the process circuit, allowing for faster and cleaner disconnection of the unit.

C-UL508A

Industrial control panel construction covers multiple requirements like proper component usage, enclosure environmental ratings, wiring and motor protection.

Two-Zone Units

Independent control of dual cooling zones using a common cooling water manifold and electrical connection.

Closed Circuit

Brazed plate heat exchanger offers isolation of the process and cooling fluid circuits.

Solid State Relay Heater Controls

Handles rapid cycling and provides a longer heater contactor life under extreme and diverse operating conditions.

Alarm Strobe and Relay Contact

Provides visual indication of an alarm condition or a dry contact for a remotely mounted alarm.

Remote Temperature Probe

Allows process temperature measurements at the die.

300°F Operating Temperature

Typically used in applications such as packaging and medical requiring higher temperatures

Certified and Calibrated RTD

For your Medical and other special requirements

Process Supply, Cooling Water In Check Valves

Prevents backflow.

Aquatherm RQT Premium Temperature Controller

Nonferrous Corrosion Resistance Package

Offers increased protection and performance through bronze or stainless fittings, castings, impellers, and flanges.

Stacking Rack

Saves floor space by stacking two units.

Flow Meter

For high-accuracy applications and monitoring of system flow (optional card to interface with existing flow meter).

SPI Communications

Communications standard for plastics processing equipment using the Serial Peripheral Interface (SPI) bus

Crash Cool Valve

Pressing Stop activates Rapid cooling for quick mold change applications

Remote Display Panel

One to one remote display of unit controller

Warranty

3 year parts and labor

Lifetime pump/heater casting

Lifetime standard pump seal

Specifications

Model	Performance Per Zone				Unit FLA		Ship	
	Heat Cap kW	Pump Motor hp	Pump Flow gpm	Pump Press psi	Single Zone 460V	Dual Zone 460V	Weight (lbs)	
							Single Zone	Dual Zone
RQT0008	0	¾	50	20	2	3	280	575
RQT0010	0	1	55	25	2	4	290	585
RQT0020	0	2	75	30	3	6	300	590
RQT0030	0	3	85	32	4	8	350	625
RQT0050	0	5	100	46	6	13	345	700
RQT0075	0	7½	120	56	9	18	360	730
RQT00TN	0	10	150	65	12	25	380	765
RQT0908	9	¾	50	20	13	26	280	575
RQT0910	9	1	55	25	13	27	290	585
RQT0920	9	2	75	30	14	29	300	590
RQT0930	9	3	85	32	15	31	350	625
RQT0950	9	5	100	46	18	36	345	700
RQT0975	9	7½	120	56	20	41	360	730
RQT09TN	9	10	150	65	24	48	380	765
RQT1208	12	¾	50	20	17	33	280	575
RQT1210	12	1	55	25	17	34	290	585
RQT1220	12	2	75	30	18	36	300	590
RQT1230	12	3	85	32	19	38	350	625
RQT1250	12	5	100	46	22	43	345	700
RQT1275	12	7½	120	56	24	48	360	730
RQT12TN	12	10	150	65	28	56	380	765
RQT1808	18	¾	50	20	24	48	280	575
RQT1810	18	1	55	25	25	49	290	585
RQT1820	18	2	75	30	26	51	300	590
RQT1830	18	3	85	32	27	53	350	625
RQT1850	18	5	100	46	29	58	345	700
RQT1875	18	7½	120	56	32	63	360	730
RQT18TN	18	10	150	65	35	71	380	765

Model	Performance Per Zone				Unit FLA		Ship	
	Heat Cap kW	Pump Motor hp	Pump Flow gpm	Pump Press psi	Single Zone 460V	Dual Zone 460V	Weight (lbs)	
							Single Zone	Dual Zone
RQT2408	24	¾	50	20	32	63	280	575
RQT2410	24	1	55	25	32	64	290	585
RQT2420	24	2	75	30	33	66	300	590
RQT2430	24	3	85	32	34	70	350	625
RQT2450	24	5	100	46	37	73	345	700
RQT2475	24	7½	120	56	39	78	360	730
RQT24TN	24	10	150	65	43	86	380	765
RQT3608	36	¾	50	20	47	94	280	575
RQT3610	36	1	55	25	47	94	290	585
RQT3620	36	2	75	30	48	96	300	590
RQT3630	36	3	85	32	49	99	350	625
RQT3650	36	5	100	46	52	103	345	700
RQT3675	36	7½	120	56	54	108	360	730
RQT36TN	36	10	150	65	58	116	380	765
RQT4808	48	¾	50	20	62	124	280	575
RQT4810	48	1	55	25	62	125	290	585
RQT4820	48	2	75	30	63	127	300	590
RQT4830	48	3	85	32	64	129	350	625
RQT4850	48	5	100	46	67	133	345	700
RQT4875	48	7½	120	56	69	139	360	730
RQT48TN	48	10	150	65	73	146	380	765

The standard set point range is 40°F to 250°F.

Aquatherm RQT Premium Temperature Controller

Dimensions

¾ HP-3 HP, 0-18 kW units

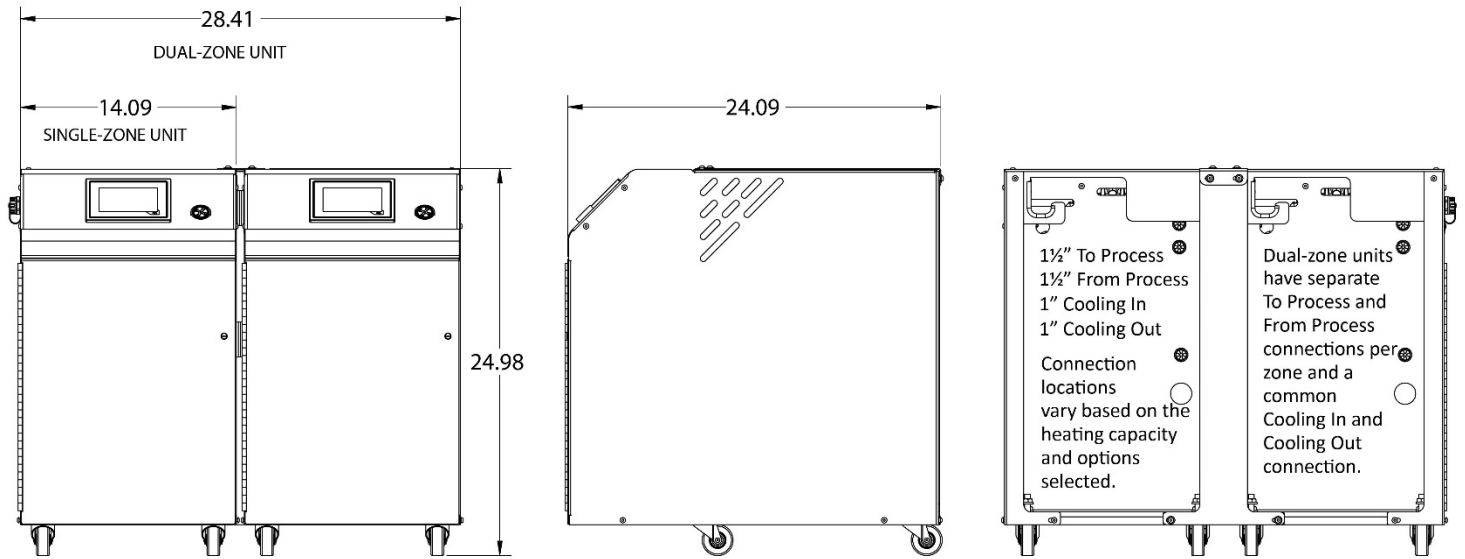

5 Hp and larger and 24 kW and higher units

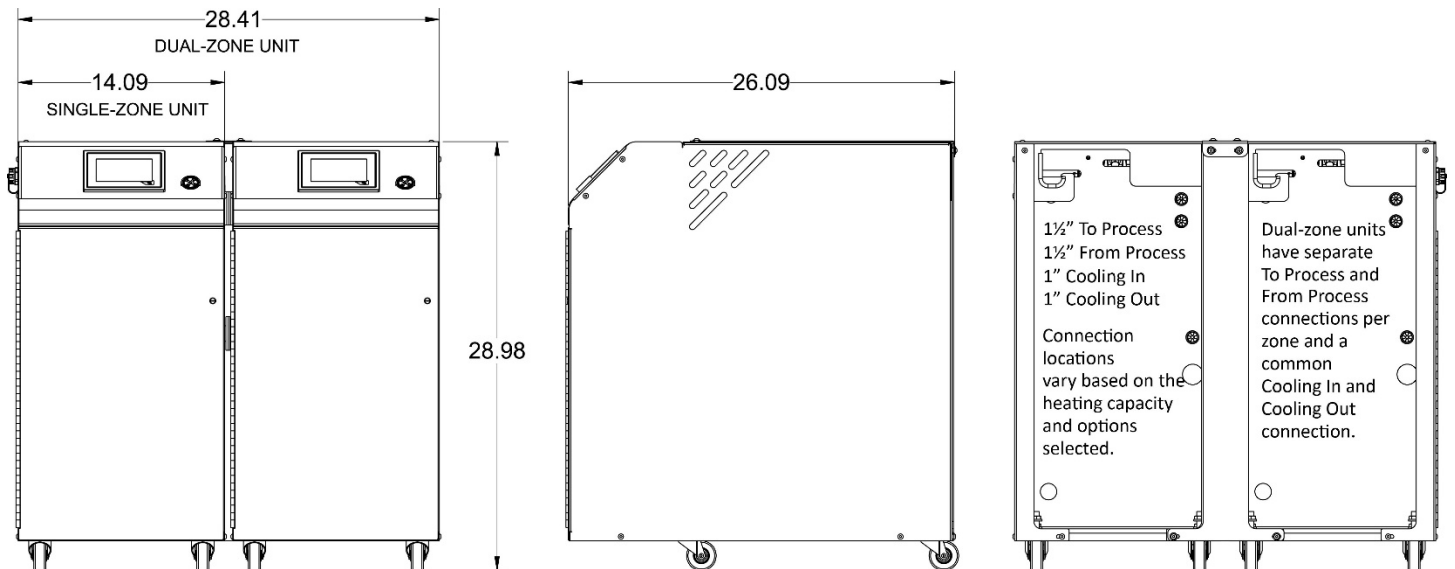

Pump Curves

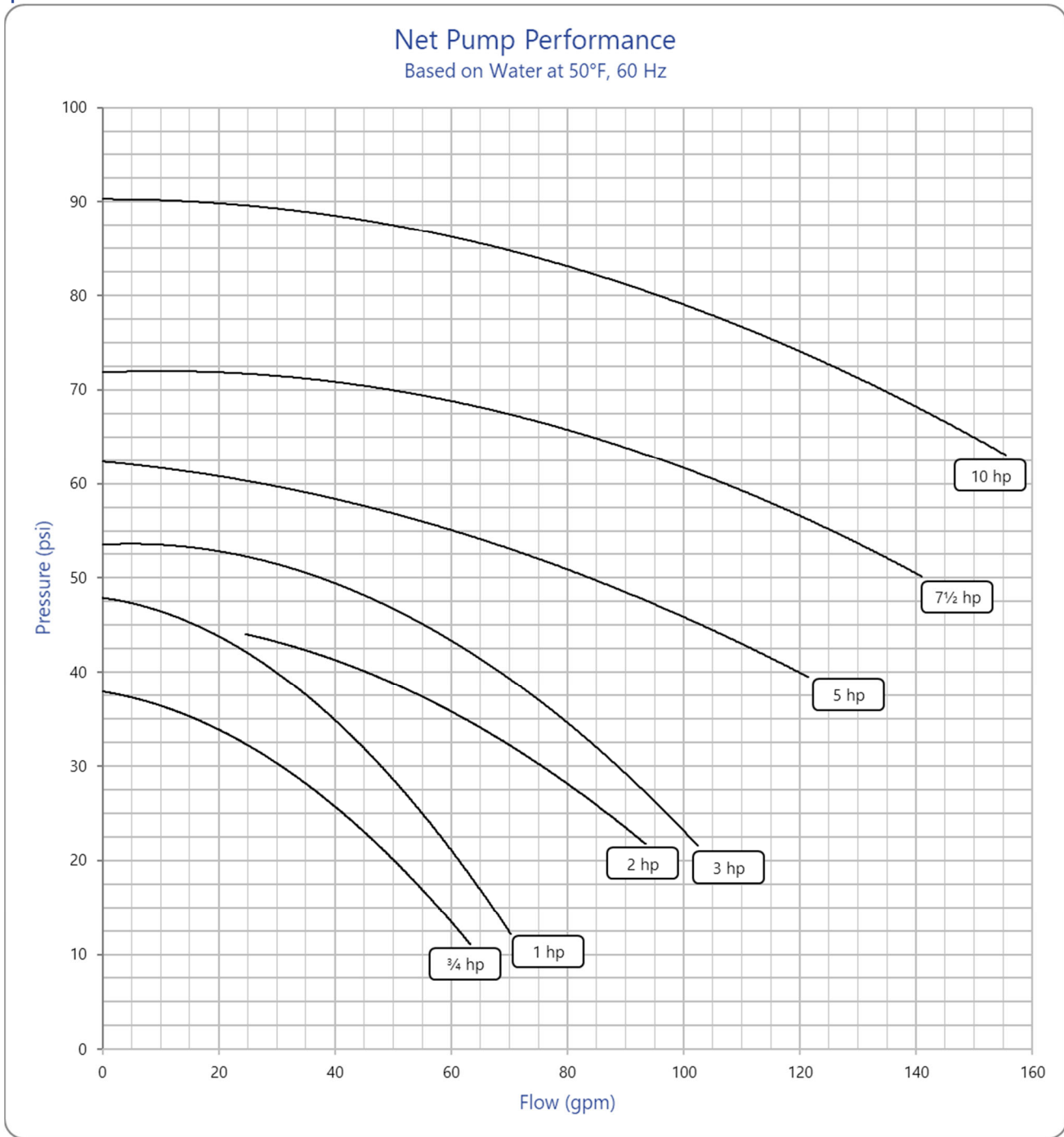

PiovanGroup

5680 W. Jarvis Ave • Niles, IL 60714
847.966.2260 • sales@thermalcare.com
www.thermalcare.com

January 2023

Thermal Care is ISO-9001 Certified
Manufacturer reserve the right to change specification
or design without notification or obligation

RQT Premium Specification 02