

CATALOG
C24

EMI[®]

CONVEYORS &
AUTOMATION SYSTEMS



Merit Line ADF Aluminum Frame | Flat Belt

Standard belt widths: 6", 9", 12", 18", 24", 30", 36"

Standard lengths: 3–30' at 1' increments

*Consult your EMI representative for other widths and lengths

This lightweight, yet strong, aluminum conveyor has a multitude of uses: under press, along side the press, overhead and assembly station conveyors, etc. A large selection of belt speeds are available. Drive horsepower will depend on selected speed and conveyor length. Also, the number of leg sets is determined by the conveyor length.



Click for 360° View!

Features

- Direct Drive configuration with 1/3 hp AC motor.
- 4–40 FPM variable speed drive.
- No roller chain or sprockets.
- Sealed gear reducer.
- 1/8" anodized aluminum construction.
- 150 lb. maximum load.
- Double V-guided, FDA approved, white PVC belt.
- 4" tall side rails lapped over conveyor belt.
- Leg sets and swivel castors included.
- 15' power cord included. Pre-wired ready to run (except polyphase systems which require some customer wiring).
- Control wiring contained in liquid-tight conduit and connectors.
- Units up to 10' length ship fully assembled.
- 3-Year Limited Warranty, see page 3.

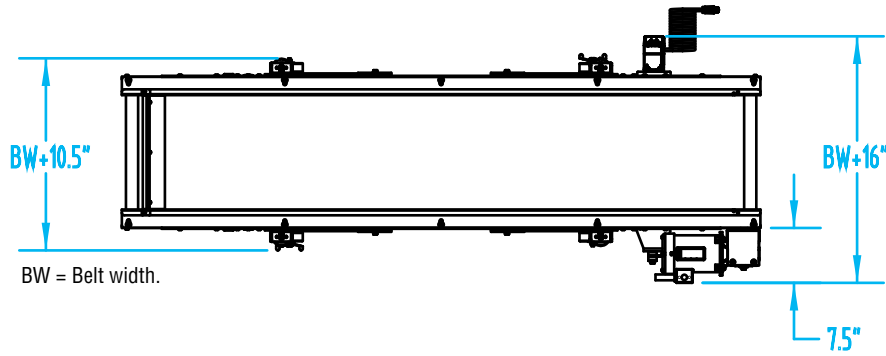

BW = Belt width.

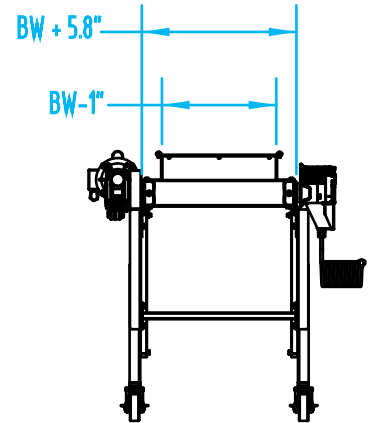
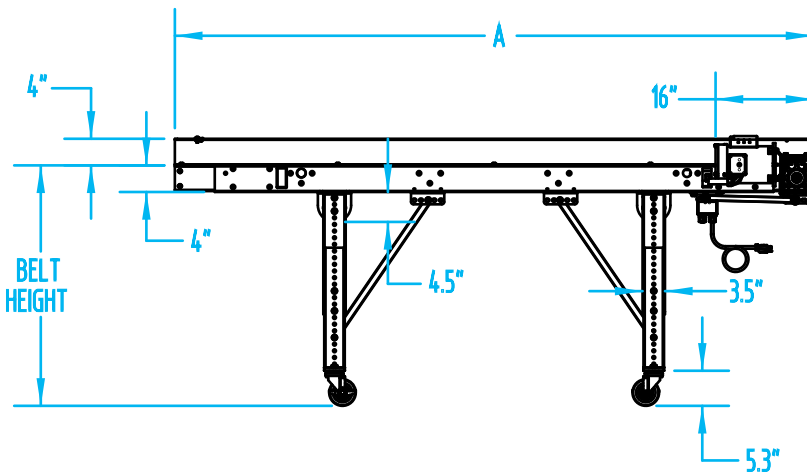

How to Order:

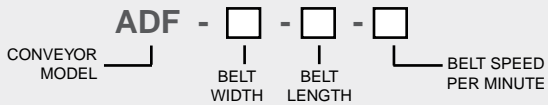

Specify the conveyor Infeed and Discharge Belt Height. Download Conveyor Specifications Form [here](#).

Common Options

- Alternate fixed and variable speed ranges available.
- Alternate voltage electrical packages.
- Robotic and box fill controls.
- Reversing, for process control.
- Side rail extensions.
- Alternate motor locations, see page 177.
- Soft drop zone, to cushion part drop.
- Side belt guards for part containment.
- Angled nose over.
- Numerous belt options, see page 106.